



2001V Series
Peristaltic Chemical Feed Pump

Installation and Operation Manual



2001V Peristaltic Chemical Feed Pump

March 16, 2011

Flomotion Systems, Inc.
165 Creekside Drive, Suite 112
Buffalo, NY 14228-2103
info@flomotionsystems.com
Toll Free: (800) 909-3569
Tel: (716) 691-3941
Fax: (716) 691-1253

TABLE OF CONTENTS

- 1.0 - System Overview.....5
 - 1.1 SAFETY.....5
 - 1.2 WARRANTY.....5
 - 1.3 RECEIVING.....6
 - 1.4 CUSTOMER MODIFICATION.....6
 - 1.5 INFORMATION FOR RETURNING PUMPS6
- 2.0 – 2001V Series Pump and Pumphead.....7
 - 2.1 TUBING, SPINDLE AND COVER INSTALLATION.....8
 - 2.2 MOUNTING PUMP ON GEARBOX, INSTALLATION OF COLLET.....9
 - 2.3 PUMP MOUNTING AND COLLET INSTALLATION PROCEDURE.....10
 - 2.4 HOSE AND ROLLER INSTALLATION.....10
 - 2.5 TUBING & CONNECTIONS.....16
- 3.0 – 2001V Series Gearbox.....18
 - 3.1 RUN-IN PERIOD.....18
 - 3.2 MAINTENANCE.....18
 - 3.3 2001V SERIES MOTOR / GEARBOX SPECIFICATIONS18
 - 3.4 2001V SERIES POWER & MOTOR WIRING.....18
- 4.0 – 2001V Series Drive Controller.....20
 - 4.1 OPERATION AND WIRING.....20
 - 4.2 PROGRAMMING20
 - 4.3 MANUAL SPEED / AUTO SPEED / RESTART TOGGLE SWITCH.....20
- 5.0 - 2001 Series Tubing Rupture Detector.....21
 - 5.1 ALARM CAUSES.....21
 - 5.2 WHAT TO DO IN AN ALARM CONDITION.....21
 - 5.3 RESETTNG THE ALARM.....21
 - 5.4 RESUMING SERVICE.....21
 - 5.5 INTERFACING.....22
 - 5.6 CALIBRATION.....22

1.0 - System Overview

The 2001V Chemical Feed Pump consists of a motor, gearbox and peristaltic pump.



1.1 Safety

In the interests of safety, this pump and the tubing selected should only be used by competent, suitably trained personnel after they have read and understood this manual, and considered any hazard involved. Any person who is involved in the installation or maintenance of this equipment should be fully competent to carry out the work.

Maintenance and repair should be performed by qualified personnel only. Make sure that no voltage is applied while work is being carried out on the pump or motor. The motor must be secured against accidental start up.

1.2 Warranty

Flomotion Systems, Inc. warrants the 2001 Series pumps to be free of defects in material and workmanship for a period of eighteen months from the date of sale to the user, or two years from the date of shipment, whichever ever occurs first. An MC Series control, or any component contained therein, which under normal use becomes defective within the stated warranty time period, shall be returned to Flomotion Systems, Inc., freight prepaid, for examination (contact Flomotion Systems, Inc. for authorization prior to returning any product). Flomotion Systems, Inc. reserves the right to make the final determination as to the validity of a warranty claim, and sole obligation is to repair or replace only components, which have been rendered defective due to faulty material or workmanship. No warranty claim will be accepted for components which have been damaged due to mishandling, improper installation, unauthorized repair and/or alteration of the product, operation in excess of design specifications or other misuse, or improper maintenance. Flomotion Systems, Inc. makes no warranty that its products are compatible with any other equipment, or to any specific application, to which they may be applied and shall not be held liable for any other consequential damage or injury arising from the use of its products. This warranty is in lieu of all other warranties, expressed or implied. No other person, firm or corporation is authorized to assume, for Flomotion Systems, Inc., any other liability in connection with the demonstration or sale of its products.

1.3 Receiving

Inspect all cartons for damage, which may have occurred during shipping. Carefully unpack equipment and inspect thoroughly for damage or shortage. Report any damage to carrier and/or shortages to supplier. All major components and connections should be examined for damage and tightness, with special attention given to PC boards, plugs, knobs and switches.

1.4 Customer Modification

Flomotion Systems, Inc., its sales representatives and distributors, welcome the opportunity to assist our customers in applying our products. Many customizing options are available to aid in this function. Flomotion Systems, Inc. cannot assume responsibility for any modifications not authorized by its engineering department.

1.5 Information for Returning Pumps

Equipment that has been contaminated with, or exposed to, body fluids, toxic chemicals or any other substance hazardous to health must be decontaminated before it is returned to Flomotion Systems or its distributor.

A certificate included at the rear of these operating instructions, or signed statement, must be attached to the outside of the shipping container.

This certificate is required even if the pump is unused. If the pump has been used, the fluids that have been in contact with the pump and the cleaning procedure must be specified along with a statement that the equipment has been decontaminated.

2.0 – 2001V Series Pump and Pumphead

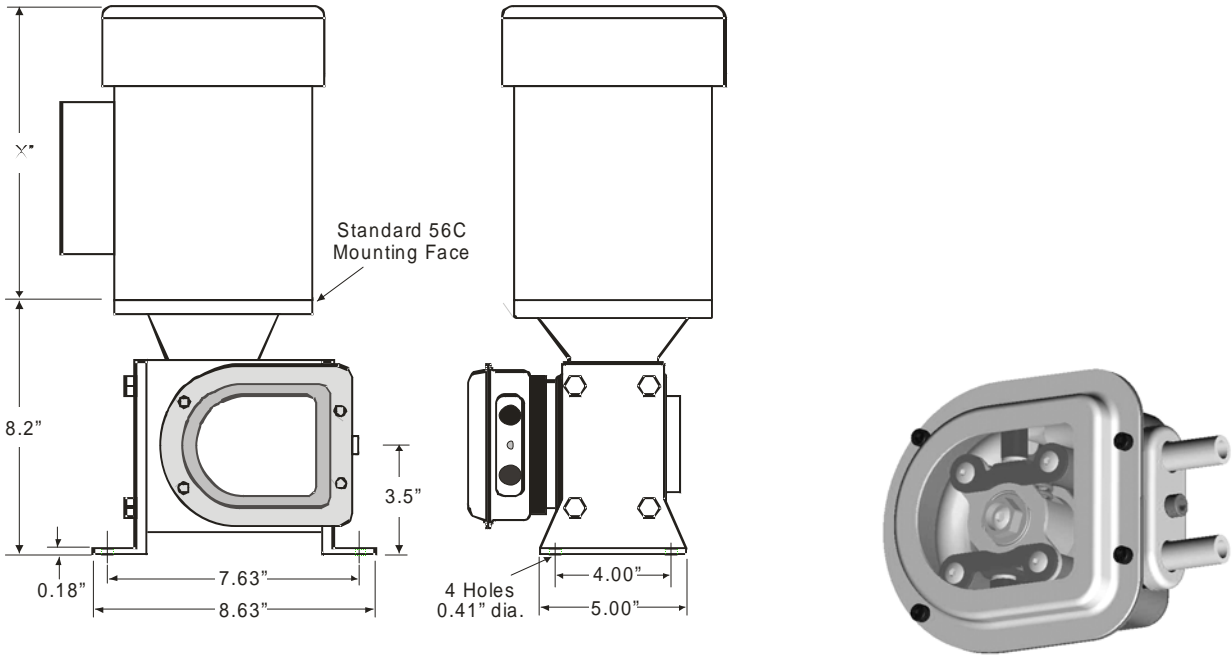

The 2001 Series pumphead has two spring-loaded working rollers, which automatically compensate for minor variations in tubing wall thickness, giving extended tube life.

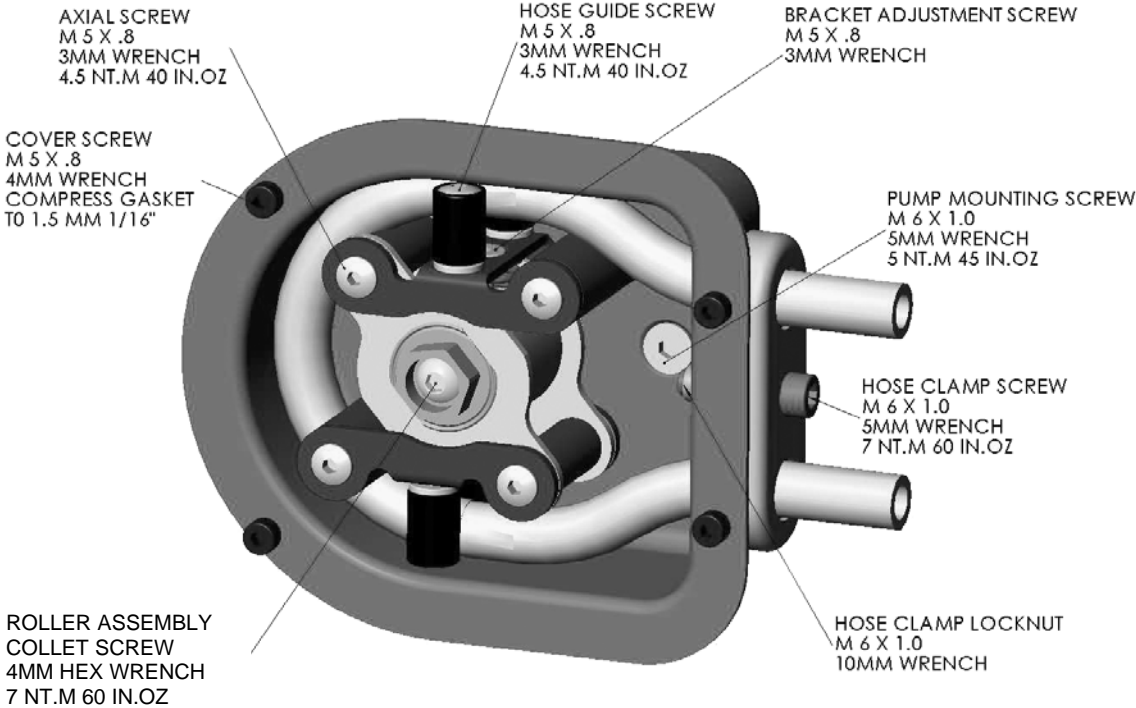

IMPORTANT: The 2001V Series is equipped with a pump cover for safety and protection against chemical spills. The cover must be installed whenever the pump is in use.

2.1 Tubing, Spindle and Cover Installation

! IMPORTANT: Disconnect pump controller from power supply BEFORE changing tubing!

Item No.	Qty	Part No.	Description
1	1	n/a	Pump Collet & Hose Assy.
2	1	100329	Roller Assembly
3	1	100330	Cover
4	1	100324	Collet Screw
5	1	100305C	Cover Gasket
6	4	100307C	Cover Screw
7	1	n/a	Tube
8	1	Varies with tubing selection*	Tube Seal

*Tube Seal PN	100329	100330	100331	100332	100333	100334
---------------	--------	--------	--------	--------	--------	--------

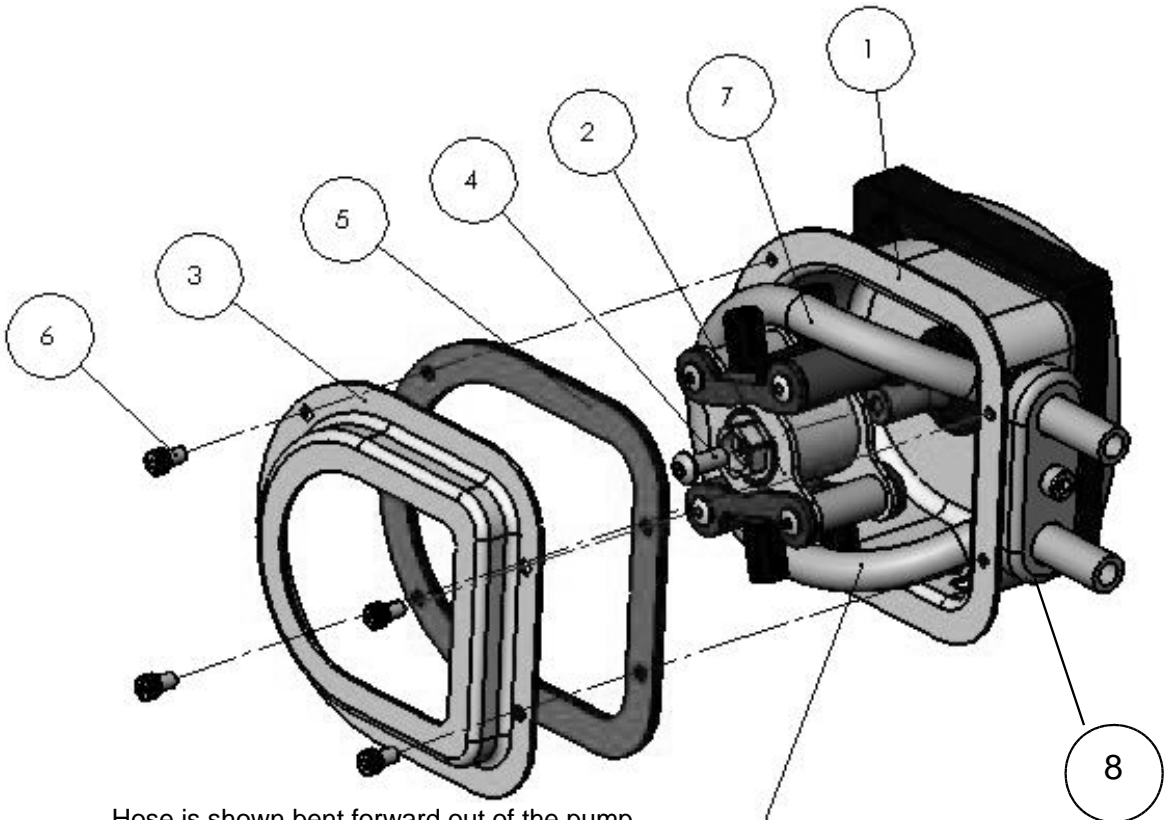

Hose is shown bent forward out of the pump housing to illustrate the correct hose and roller assembly position, prior to sliding the hose and spindle into the housing and over the collet.

2.2 Mounting Pump on Gearbox, Installation of Collet

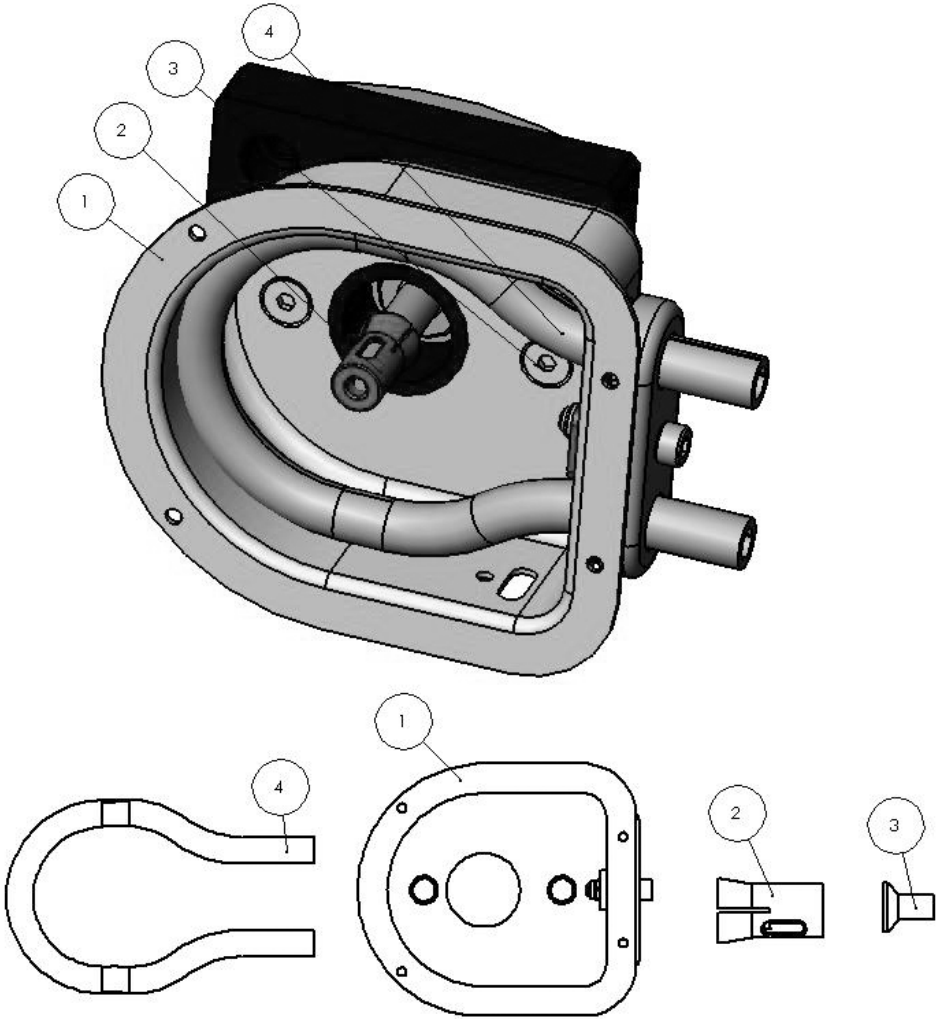

Item No.	Qty	Part No.	Description
1	1	NA	Pump Housing with Tube Seal
2	1	100306	Collet
3	2	100330	Pump Mounting Screws
4	1	NA	Tubing

2.3 Pump Mounting and Collet Installation Procedure

1. To install the pump housing on the gearbox, slide it over the central pilot on the gearbox adaptor plate. Next install and torque the mounting screws to 5 NT.M (45 in. oz).
2. Next install the collet on the gearbox shaft. There is a slot in the collet that the flat drive tang on the gearbox shaft must slide into. Orient the collet to allow the drive tang to slide into the slot and push the collet completely onto the gearbox shaft. When the collet bottoms out it is in the correct position.

2.4 Hose and Roller Installation

! IMPORTANT: Disconnect pump controller from power supply **BEFORE** changing tubing!
Make sure pump suction and discharge lines are completely drained and isolated.
Note that the hose seal size must match the selected tubing size.

Disassembly:

1. Remove four (4) 4mm pump cover screws.
2. Loosen Tube Seal Clamp Screw with 5mm hex wrench.



3. Remove 5mm collet screw.



4. Remove the roller assembly.

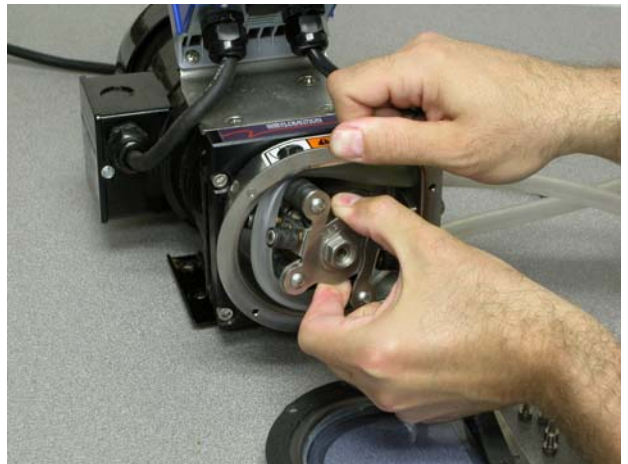

5. Remove worn pump tubing from pumphead.



6. Remove and inspect collet for wear. Note that the collet may remain in the roller assembly when the roller assembly is removed from the pump shaft.



7. Clean inside of pump housing with damp rag or an appropriate cleaning solution to remove any chemical or tubing residue.



Reassembly:

1. Reinstall the collet onto the pump shaft.

There is a slot in the collet that the flat drive tang on the gearbox shaft must slide into. Orient the collet to allow the drive tang to slide into the slot and push the collet completely onto the gearbox shaft. When the collet bottoms out it is in the correct position.



2. Mark an 11" section of hose, which will be the portion, contained within the pump. Leave sufficient excess on the suction and discharge sides of the pump for the desired connections. If you leave the excess intake tubing in a coil near the pump it will make it easy to feed a new section of tubing through the rollers when the section in the pump becomes worn.

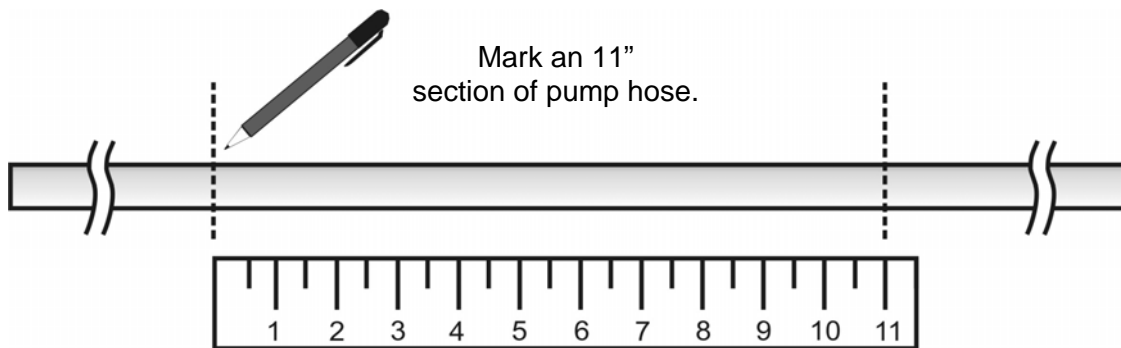

3. Install tubing into the pumphead.

Note: During hose installation the loop of tubing may develop a twist. Examine the hose for this condition and if needed turn one end of the hose where it exits the tubing clamp to eliminate the twist. Correctly adjusted the tubing loop will be flat and parallel to the front face of the pump housing.



4. Loop tubing around roller assembly between guides as shown. Remove slack in tubing while rotating roller assembly and sliding onto collet.



5. Align marks on tubing with outside edge of the tubing clamp.

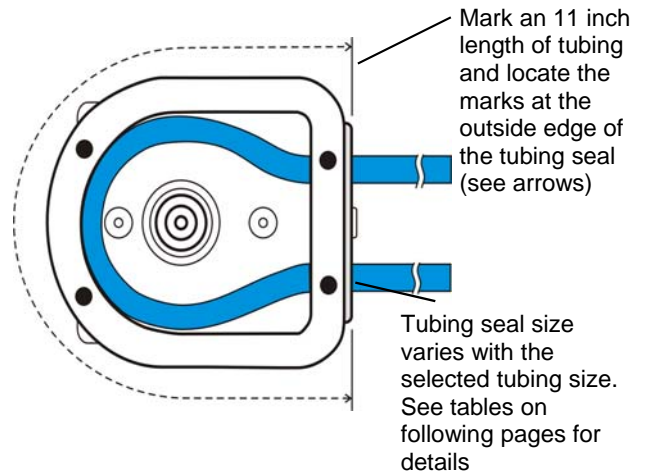

6. Reinstall collet screw firmly.



7. Tighten tube seal clamp screw. Be sure to tighten firmly to prevent "tubing walk." Tubing walk can occur when the tube seal is the wrong size or is not sufficiently tight to keep the rollers from pulling the tubing through the pump as it rotates.

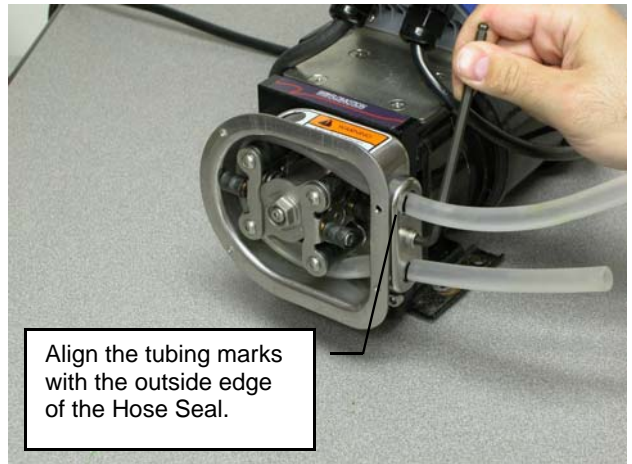

8. Inspect pump cover gasket. Replace if damaged. Reinstall pump cover gasket and cover.



2.5 Tubing & Connections

Tubing adapters are available for many configurations. See the drawing below for details.

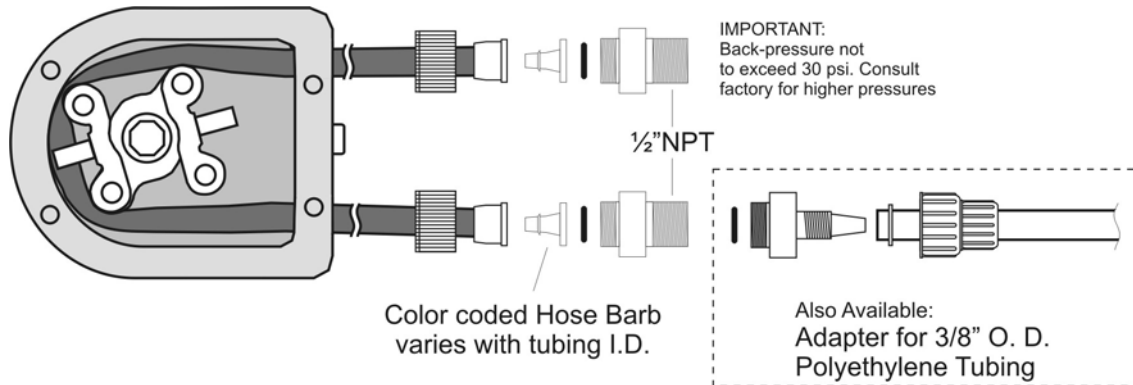

2001V Series Estimated Pumping Capacity						
Tubing No.	#119	#120	#15	#24	#35 & 121	#36 & 122
Tubing Size	1.6mm bore (1/16")	3.2mm bore (1/8")	4.8mm bore (3/16")	6.4mm bore (1/4")	8mm bore (5/16")	9.6mm bore (3/8")
ml/min @ 0.6-90 rpm	0.27 - 41 (0.004 - 0.64 gph)	1.13 - 169 (0.02 - 2.68 gph)	2.46 - 369 (0.04 - 5.85 gph)	4.44 - 666 (0.07 - 10.56 gph)	6.60 - 990 (0.10 - 15.69 gph)	8.64 - 1296 (0.14 - 20.54 gph)
ml/min @ 1.8 - 220 rpm	0.81 - 99 (0.013 - 1.57 gph)	3.38 - 414 (0.05 - 6.56 gph)	7.38 - 902 (0.12 - 14.30 gph)	13.32 - 1628 (0.21 - 25.80 gph)	19.80 - 2420 (0.31 - 38.36 gph)	25.92 - 3168 (0.41 - 50.21 gph)
ml/rev*	0.45	1.88	4.1	7.4	11	14.4
Hose Barb Color	Violet	Green	White	Black	Gray	Blue
Hose Seal PN	100329	100330	100331	100332	100333	100334

Tubing and Accessory Part Numbers					
FLOPRENE TUBING - 50 Ft Length (Santoprene)					
FLO.016.024	1.6mm (1/16") bore	100 PSI max	FLO.064.024	6.4mm (1/4") bore	50 PSI max
FLO.032.024	3.2mm (1/8") bore	100 PSI max	FLO.080.024	8.0mm (5/16") bore	30 PSI max
FLO.048.024	4.8mm (3/16") bore	70 PSI max	FLO.096.024	9.6mm (3/8") bore	30 PSI max
CONNECTORS / ADAPTORS					
1/2" NPTM x pump tubing (bore as required)					
3/8" PE tubing x pump tubing (bore as required)					
Two-piece Color Coded tubing Barb & Collar Set.					
PUMPHEAD tubing SEALS					
100329 tubing Seal	1.6mm (1/16") bore		100332 tubing Seal	6.4mm (1/4") bore	
100330 tubing Seal	3.2mm (1/8") bore		100333 tubing Seal	8.0mm (5/16") bore	
100331 tubing Seal	4.8mm (3/16") bore		100334 tubing Seal	9.6mm 3/8") bore	

Tube connector adapter order guide

TUBING CONECTORS ONLY – Does not include hose barb and collar set.

-
- 1 2 3 4 5 6 7 8
- 1 – 3 Process Connection Size**
 - 038 3/8" OD - PE Tubing Only
 - 050 1/2" OD – PE Tubing or 1/2" NPT

 - 4 Process Connection Type**
 - T PE Tubing
 - N NPT

 - 5 – 6 Pump Tubing Side**
 - PT Pump Tubing Side

 - 7 Connector Body Material of Construction**
 - P PVC
 - T PTFE (Teflon)
 - K PVDF (Kynar)
 - X Other

 - 8 O-Ring Material of Construction**
 - V Viton
 - E EPDM

3.0 – 2001V Series Gearbox

3.1 Run-in Period

The maximum efficiency of worm reducers is obtained after a “Run-In” period. The length of time required will depend on the load applied and may be two to four hours at rated load and will be considerably longer at lighter loads. During Run-In a slightly higher than normal current and temperatures along with lower efficiency and output torque can be expected.

3.2 Maintenance

- Frequently check the oil level.
- Change lubricant every 6,000 (240 days) working hours or after 2 years (synthetic lubricants only).
- Combine a lubricant change with a thorough cleaning of the gear unit.
- Extreme working conditions (high air humidity, aggressive media and large temperature variations) will reduce the interval between lubricant changing intervals.
- All drives are shipped with Mobil SHC 634 or equal synthetic oil.

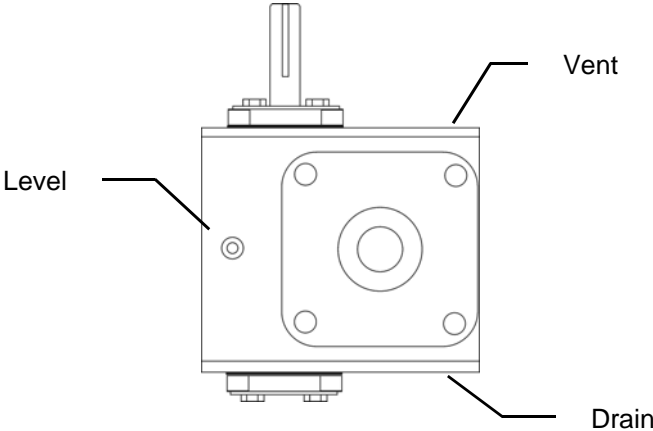

3.3 2001V Series Motor / Gearbox Specifications

- Motor Type: Permanent Split Capacitor or 3-Phase Inverter Duty
- Rotation: Reversible.
- Insulation: Class B minimum
- Finish: Powder-coat gloss black.

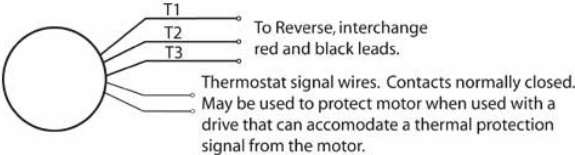

Inverter Duty 3 Phase 230 V

(Thermostat wires not used)

3.4 2001V Series Power & Motor Wiring

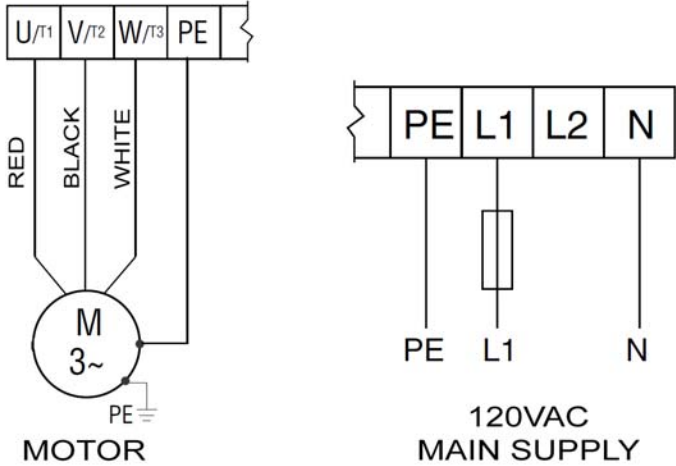

4.0 – 2001V Series Drive Controller

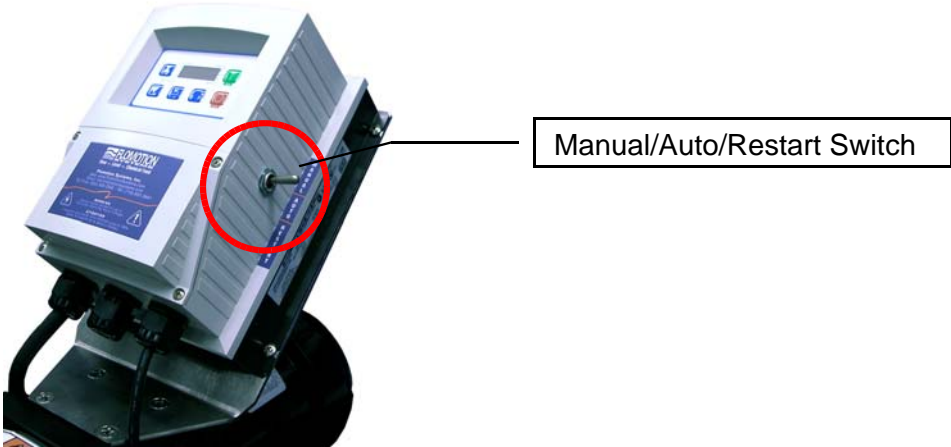

4.1 Operation and Wiring

For complete details about the motor drive controller please refer to the included SM Vector Operating Instructions booklet. Shown on the following pages are details specific to the operation with the 2001HE Peristaltic Pump operation.

4.2 Programming

The programming differs from the factory defaults shown in the SM Vector Operating Instruction booklet only in relation to the following parameters:

P103	Maximum Frequency	75 Hz (60HZ for explosion proof motor)
P104	Acceleration Time	5 sec
P105	Deceleration Time	5 sec
P121	TB-13A Input	(2) AUTO Reference 4-20mA
P161	Speed at Maximum Signal	75 Hz
P162	Analog Input Filter	0.5 sec
P166	Carrier Frequency	(2) 8kHz

4.3 Manual Speed / Auto Speed / Restart Toggle Switch

The Auto/Manual/Restart toggle switch is located on the right side of the motor drive controller.

Manual Mode

When the switch is placed in the MANUAL (TOP) position the pump speed may be controlled by the up and down arrow keys on the controller.

Auto Mode

When the switch is placed in the AUTO (CENTER) position the speed is controlled by an external 4-20mA signal applied to pin 2 (-) and pin 25 (+) of the terminal block.

Restart Mode

When the pump is stopped by pressing the STOP button on the front panel or via a stop signal from a remote source such as a PLC or remote stop switch then you must use the Restart Toggle switch to restart the pump. Momentarily press the toggle switch down to restart the pump.

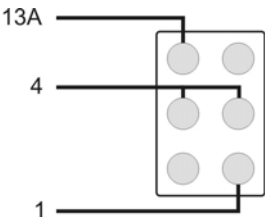

Rear View of Manual/Auto/Restart Switch showing wiring to terminal block.

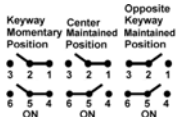

5.0 - 2001 Series Tubing Rupture Detector

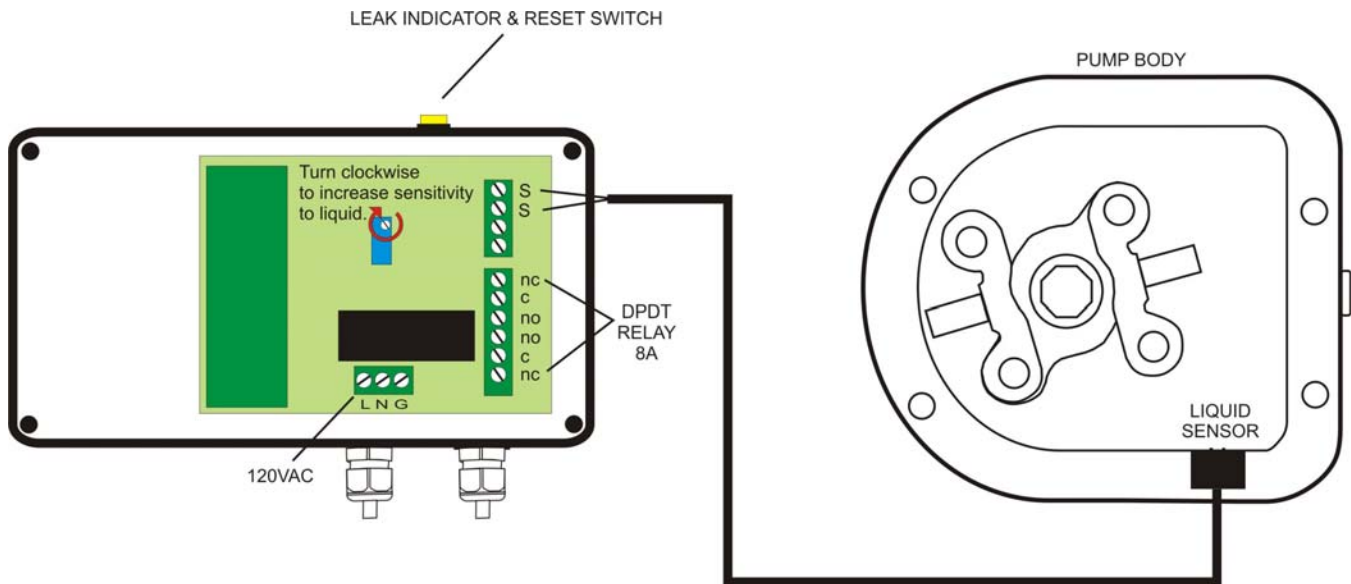

5.1 Alarm Causes

A rupture alarm is triggered by the presence of a conductive fluid in the pump. When the fluid bridges the two stainless steel electrodes on the LIQUID SENSOR the alarm is triggered.

5.2 What to do in an alarm condition

To clear the alarm, first stop the pump and **disconnect power from the pump controller**. Remove the pump cover and remove the ruptured pump tubing. Clean the inside of the pump with a soft rag. Remove any liquid or tubing debris from the inside of the pump and the area around the LIQUID SENSOR. Inspect rollers and clean if necessary.

5.3 Resetting the alarm

Press the yellow pushbutton (LEAK INDICATOR & RESET SWITCH) on the top of the Tubing Rupture Detector to reset the alarm.

5.4 Resuming Service

Install a fresh tubing insert and the pump is ready to resume service.

5.5 Interfacing

A dual 8 Amp DC DPDT relay is provided to signal or control an external device during an alarm condition. Connect the Tubing Rupture Detector Normally Closed (NC) relay contacts in series with the wire going to pin 1 of the SMVector pump controller.

Standard Wiring:

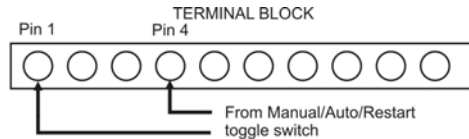

Tubing Rupture Detector Pump Shut-off wiring:

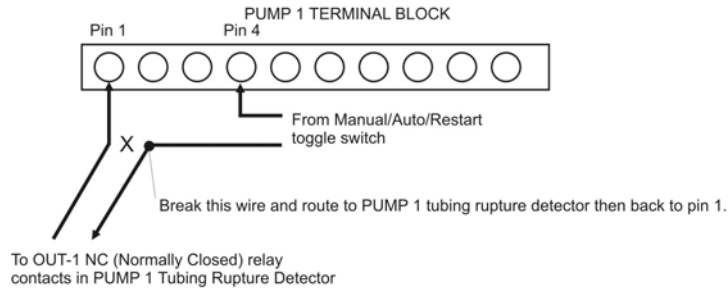

Tubing Rupture Detector Pump Backup Switchover wiring:

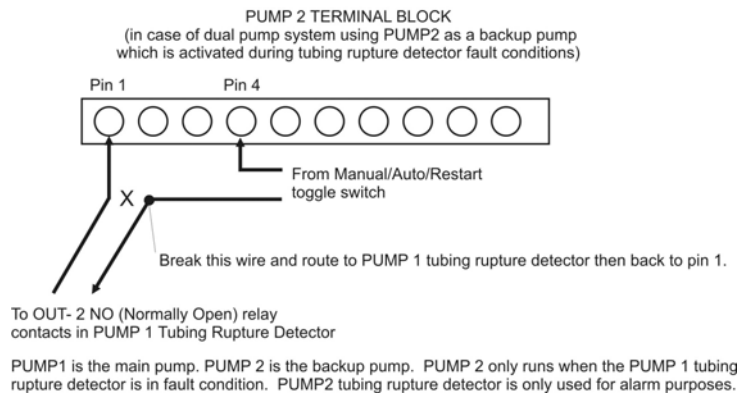

Program the SMVector Pump Controller step P100, changing the value from 0 to 1.

To do this:

1. Press the M key.
2. Enter password 0225 by holding down the UP arrow key then press the M key when done.
3. P100 is shown on the display.
4. Press the M key and change the P100 value from 0 to 1(Terminal Strip), then press the M key to save your change.

The pump is now set to run only when the Tubing Rupture Detector is not in alarm condition.

5.6 Calibration

Turn the sensitivity adjusting screw counter clockwise several turns. Apply a wet rag to the LIQUID SENSOR electrodes. Adjust the sensitivity clockwise slowly until the alarm trips.

