

Model 2305D™ Economical Digital Dual Cylinder Scale

- Designed for weighing cylinders up to 12" in diameter
- Two independent weighing bases and digital LCD displays
- Base sizes: 12-5/8" x 14-3/4"
- Net capacity: Up to 150 lbs. (68 or 70 kg) per base
- High accuracy of $\pm 0.25\%$ of capacity
- Single or multi-channel controllers with easy readability to 0.1 lb. (kg)
- Readout in pounds, kilograms, gallons or liters



AccuPro 5000-EK™
Controller - Knob



AccuPro 5000-PB™
Controller - Keypad



1099™ Chemical
Process Controller



Economical Scale is Designed for Weighing Two Gas Cylinders Simultaneously

Model 2305D is designed for weighing two gas cylinders up to 12" in diameter. Featuring an economical single load cell design, the low-profile base and adjustable backstop allows for safe and easy handling and centering of cylinders. MADE IN USA.

Standard Features

- Rugged steel construction protected by a corrosion resistant, zinc oxide primed and dry powder epoxy coated finish, with solid 1/4" PVC decking for use in harsh environments
- Low profile platform design (1.56") increases safety and ease of cylinder handling
- Designed for centered loads – includes heavy-duty steel backstop with measuring guides to help position the cylinder
- Two (2) stainless steel, temperature compensated button load cells
- All hardware is stainless steel to prevent corrosion
- Mounting holes for securing base frame to floor
- Electronic indicator housed in NEMA 4X, UL approved enclosure to provide protection from acids
- 12 ft. of 4 conductor wire cable
- Cylinder support with tool rack and chains

Available Controllers

- AccuPro 5000 Digital Controller with one or 2 channels, encoder knob or 3 button keypad, audible alarm and 4-20 mA output signal – scale or loop powered
- Model 1099 Chemical Process Controller with 1 to 4 channels, 20 button keypad and 4-20 mA output signal – scale or loop powered

Options

- High and low level set points
- 0-5V or 0-10V output signal
- Remote mounting of indicator box up to 200 feet away

Chemicals

- Scale is designed to accurately measure weight of ammonia, carbon dioxide, hydrogen chloride, liquefied chlorine, sulfur dioxide and other liquid gases

Model 2305D™ Economical Digital Dual Cylinder Scale Specifications

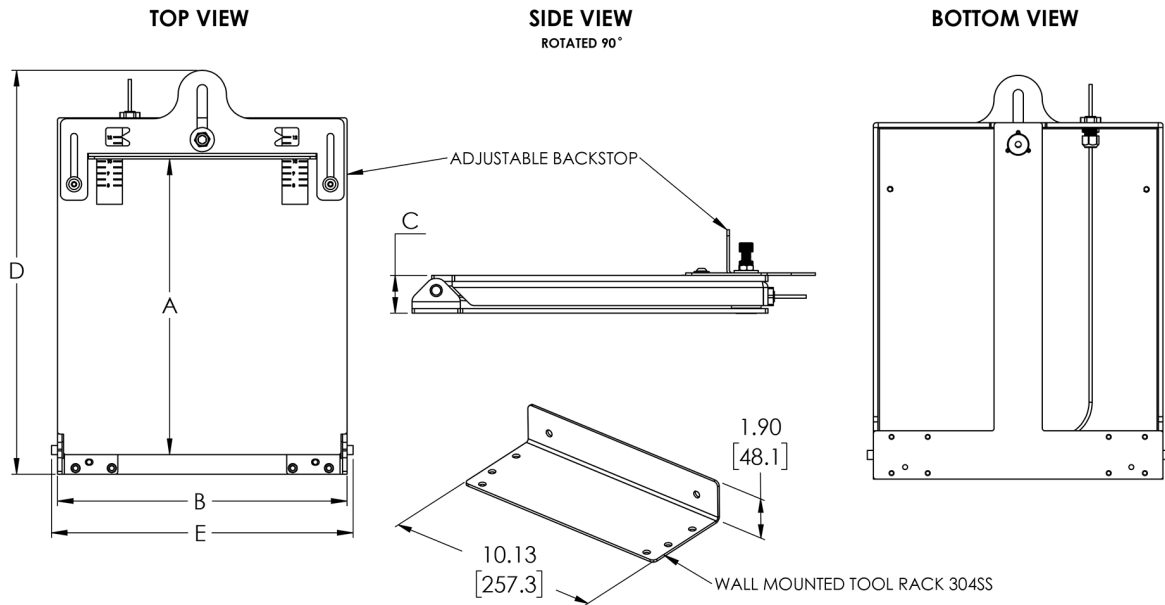

Scale Base

PART NUMBER	2305D
Platform Length (A)	12.24" (311 mm)
Platform Width (B)	12.00" (309 mm)
Platform Height (C)	1.56" (40 mm) each
D	16.72" (425 mm)
E	12.50" (318 mm)
Net Capacity	Up to 150 lbs. (60 or 70 kg) for each base
Weight	46 lbs.

Digital Controllers

PART NUMBER	ACCUPRO 5000-EK	ACCUPRO 5000-PB	1099 C.P.C.
Interface	Encoder knob	Keypad with three (3) push buttons	20 Button keypad
Accuracy	±0.1% to ±0.25% of full scale capacity	±0.1% to ±0.25% of full scale capacity	±0.1% to 0.25% of full scale capacity
Display	6 Digit alphanumeric backlit LCD	6 Digit alphanumeric backlit LCD	6 Digit LED & alphanumeric backlit LCD
Display Units	Pounds, kilograms, gallons or liters	Pounds, kilograms, gallons or liters	Pounds, kilograms, gallons or liters
Channels	1 or 2 - One scale base per channel	1 or 2 - One scale base per channel	Up to 4
4-20 mA	4-20mA Standard, 0-5V or 0-10V optional - 1 Output per channel, scale or loop powered	4-20mA Standard, 0-5V or 0-10V optional - 1 Output per channel, scale or loop powered	Standard on channel 1 - Loop powered (available for channels 2 thru 4)
Set Points	2 or 4 Per channel (high or low)	2 or 4 Per channel (high or low)	1 to 4 (high or low)
Remote Mounting	Up to 200 feet from base frame	Up to 200 feet from base frame	Up to 200 feet from base frame
Audible Alarm	Piezo buzzer with adjustable volume	Piezo buzzer with adjustable volume	Optional piezo buzzer with adjustable volume
Power	120/240 VAC, 50/60 Hz, 0.10/0.05A	120/240 VAC, 50/60 Hz, 0.10/0.05A	120/240 VAC, 50/60 Hz, 0.10/0.05A
Enclosure	NEMA 4X, UL approved enclosure	NEMA 4X, UL approved enclosure	NEMA 4X, UL approved enclosure
Weight	7 lbs.	7 lbs.	9 lbs.

Scaleton Industries Ltd.

Bedminster Industrial Park
53 Apple Tree Lane • P.O. Box 365
Plumsteadville, PA 18949 • USA

Tel: (+1) 215-766-2670 (International)
Tel: (+1) 800-257-5911 (USA & Canada)
Fax: (+1) 215-766-2672

Email: info@scaletonscales.com
Website: www.scaletonscales.com