

## Model 2330™ Mechanical Dual Cylinder Scale

- Designed for weighing cylinders up to 12" in diameter
- Two independent weighing disks and dials
- Base size: 32" x 18"
- Net capacity: Up to 150 lbs. (70 kg) per disk
- High accuracy of  $\pm 1\%$  of capacity
- Mechanical spring and lever movement
- Readout in pounds or kilograms
- Patented



### Dual Mechanical Scale is Ideal for Locations Where Power is Not Readily Available

Model 2330 is designed for weighing two gas cylinders up to 12" in diameter. Featuring a three-point suspension on the weighing disks, the low-profile base allows for safe and easy handling of cylinders. MADE IN USA.

#### Standard Features

- Rugged steel construction protected by a corrosion resistant, zinc oxide primed and dry powder coated finish, with molded fiberglass reinforced thermoplastic base and weighing disks for use in harsh environments
- Low profile platform design (1-1/2") increases safety and ease of cylinder handling
- Spring dial displays, one per each cylinder housed in molded fiberglass reinforced thermoplastic enclosure to provide protection from acids
- All hardware is stainless steel to prevent corrosion
- Self-locking tare adjustment knob
- Cylinder support and chains

#### Indicator Options

- Dials available in pounds or kilograms

#### Chemicals

- Scale is designed to accurately measure weight of ammonia, carbon dioxide, hydrogen chloride, liquefied chlorine, sulfur dioxide and other liquid gases

# Model 2330™ Mechanical Dual Cylinder Scale Specifications

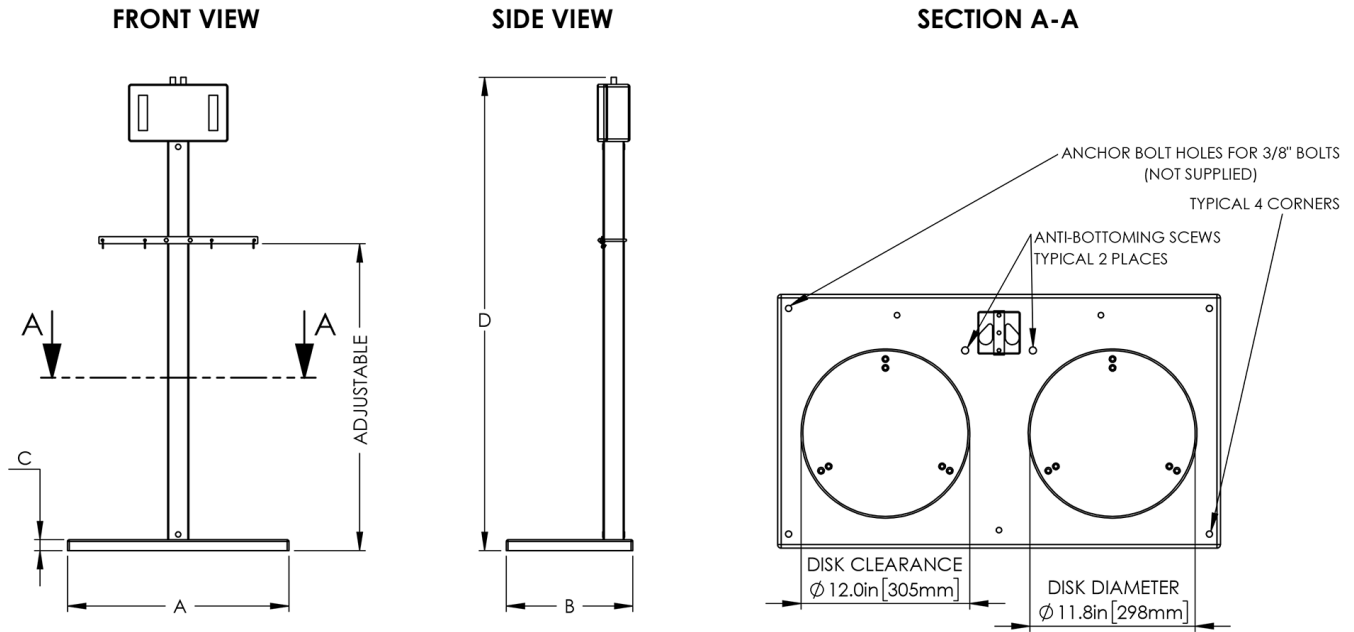

## Scale Base

PART NUMBER	2330
Platform Length (A)	31.5" (800 mm)
Platform Width (B)	18.0" (457 mm)
Platform Height (C)	1.50" (38 mm)
D	67.2" (1707 mm)
Net Capacity	Up to 150 lbs. (70 kg) per disk
Weight	58 lbs.