



Smith-Blair
a xylem brand

Installation Instructions

274

Bell Joint Leak Clamp 2" – 14" Sizes

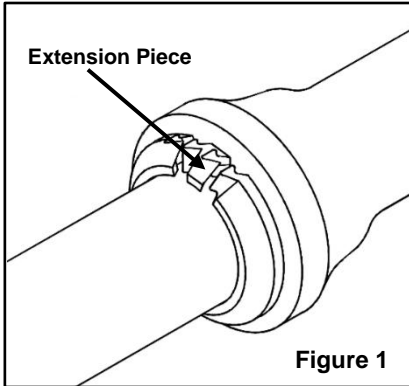

Figure 1

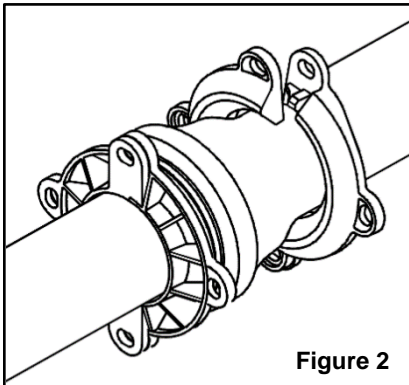

Figure 2

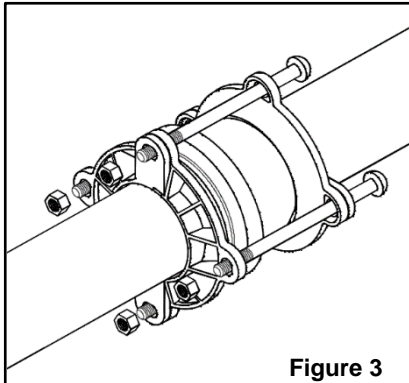

Figure 3

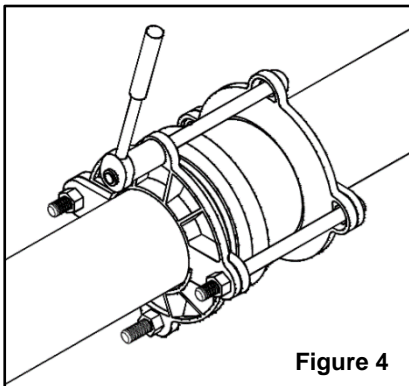

Figure 4

STEP 1

Inspect the shipment received to ensure no damage has occurred during transit or storage and that no hardware is missing. Ensure the received bell joint leak clamp is the correct size for the installation prior to beginning.

STEP 2

Clean pipe joint thoroughly on back of bell, on bell face and on spigot where gasket will seat. Be sure to remove any scale, dirt, or debris that could affect the gasket seal.

STEP 3

Inspect the joint. For caulked joint installations, caulking should be flush with bell face as far as practical. Caulking should not extend beyond bell face. If recessed more than 1/8", it should be faced up with a suitable material. Keep excess material off the spigot and bell face.

STEP 4

For 2"-12" sizes, wrap gasket around pipe with beveled side facing away from bell face and connect ends. Gasket is provided with a Kee-Lok™ extension piece which is only to be used on larger diameter Class C-D pipe. (See Figure 1).

For 14" size, wrap gasket around pipe with beveled side facing away from bell face. Carefully trim any extra gasket length with a sharp knife, being sure to maintain the bias cut angle. The gasket can be held in place by stapling the two ends together using a common office stapler.

STEP 5

For 2"-12" sizes, assemble Spigot Ring and Bell Ring onto pipe by interlocking the flange halves. (See Figure 2)

For 14" size, connect flange halves by installing cap screws in the side flanges. Tighten screws.

STEP 6

Install bolts and nuts hand tight being sure that all components are in alignment. Nuts should be located on spigot end. (See Figure 3)

STEP 7

Tighten nuts progressively and uniformly to recommended torque value below.

NUT SIZE	TORQUE VALUE
5/8"	60-70 FT. LBS.

*Use of a calibrated torque wrench is recommended!
(Figure 4)*

STEP 8

Check for leakage and recheck bolts for proper torque prior to backfilling. If possible, nuts should be checked for tightness 12-24 hours after initial tightening.

See Reverse Side for Detailed Cut-Away View and Warnings



36 Hudson Rd
Sudbury MA 01776



800-225-4616
www.tisales.com



Smith-Blair
a xylem brand

Installation Instructions

274

Bell Joint Leak Clamp 2" – 14" Sizes

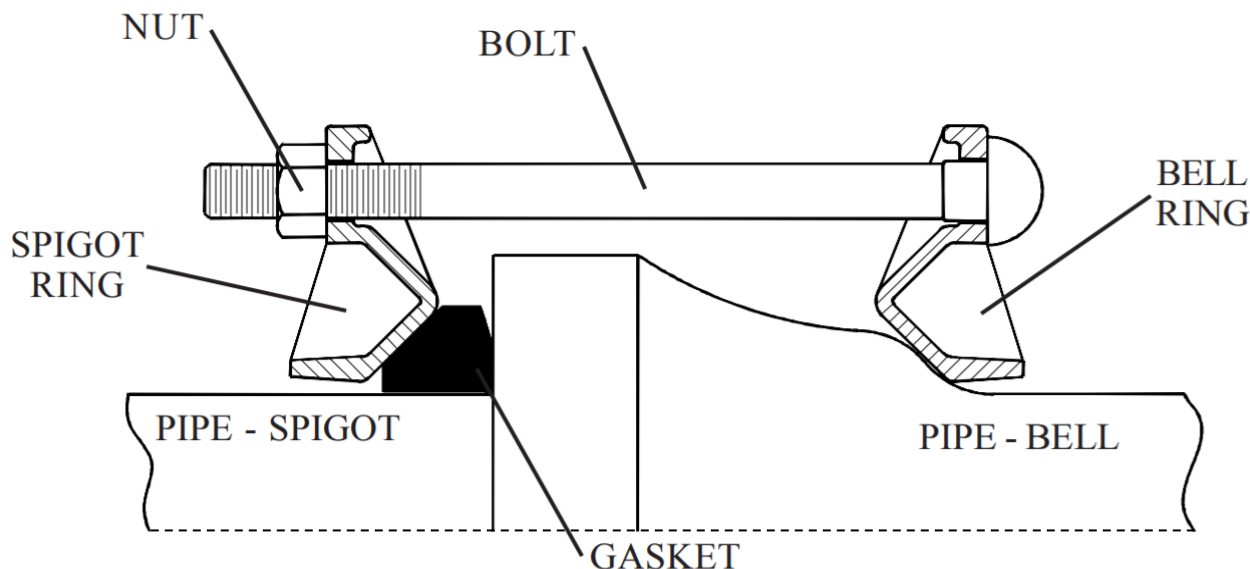

THIS PRODUCT DOES NOT RESTRAIN PIPE MOVEMENT. Proper anchoring is required to prevent pipe pull out. Failure to anchor or improper anchoring can result in dangerous pipe content escape, property damage, serious injury, and/or death. Read the product installation instructions prior to installing this product.

WARRANTY

Smith-Blair, Inc. warrants its products to be free of defects in materials and workmanship for a period of one (1) year from the date of shipment by Smith-Blair, Inc. (the "Warranty Period"). Dated proof of purchase, such as a bill of sale, is required to establish warranty eligibility. If a product fails to perform due to a defect in materials or workmanship during the Warranty Period, Smith-Blair, Inc. will repair or, at Smith Blair, Inc.'s option, replace the product with the same or comparable item. In the event that the product cannot be repaired and a suitable replacement item is not available, Smith-Blair, Inc. will refund the original purchase price shown on the proof of purchase. In all cases, the customer is responsible for returning the allegedly defective product to the factory or warehouse designated by Smith-Blair, Inc.

THIS LIMITED WARRANTY IS EXCLUSIVE AND IS IN LIEU OF ANY EXPRESS OR IMPLIED WARRANTY OF MERCHANTABILITY, FITNESS FOR A PARTICULAR PURPOSE, OR OTHER WARRANTY OF QUALITY, OR THOSE ARISING FROM A COURSE OF DEALING, CUSTOM, OR USAGE OF TRADE. THE REMEDIES PROVIDED IN THIS LIMITED WARRANTY STATEMENT ARE THE CUSTOMER'S SOLE AND EXCLUSIVE REMEDIES. IN NO EVENT SHALL SMITH-BLAIR, INC. BE LIABLE FOR DIRECT, INDIRECT, SPECIAL, INCIDENTAL, OR CONSEQUENTIAL DAMAGES, WHETHER BASED ON CONTRACT, TORT, OR ANY OTHER LEGAL THEORY, AND WHETHER ADVISED OF THE POSSIBILITY OF SUCH DAMAGES.

04/18

CORROSION & PRODUCT SELECTION NOTICE

Metal products are subject to corrosion, particularly when used outdoors and/or underground. A large number of factors and local conditions affect the rate of corrosion. Consult a local corrosion expert to determine the life expectancy of this product when used with your pipeline content, soil, and environment. Also, consult your system designer to determine the suitability of this product in your piping system. Failure to determine the suitability of this product in your application, soil, and/or environment can result in premature product failure. Smith-Blair will provide additional information about this product's material specifications at your request. You may also obtain product information at www.smith-blair.com.

04/18



Smith-Blair
a xylem brand

Installation Instructions

274

Bell Joint Leak Clamp 16" – 36" Sizes

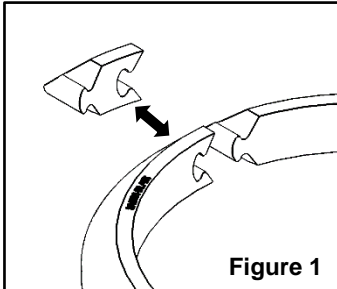

Figure 1

STEP 1

Inspect the shipment received to ensure no damage has occurred during transit or storage and that no hardware is missing. Ensure the received bell joint leak clamp is the correct size for the installation prior to beginning.

STEP 2

Clean pipe joint thoroughly on back of bell, on bell face and on spigot where gasket will seat. Be sure to remove any scale, dirt, or debris that could affect the gasket seal.

STEP 3

Inspect the joint. For caulked joint installations, caulking should be flush with bell face as far as practical. Caulking should not extend beyond bell face. If recessed more than 1/8", it should be faced up with a suitable material. Keep excess material off the spigot and bell face.

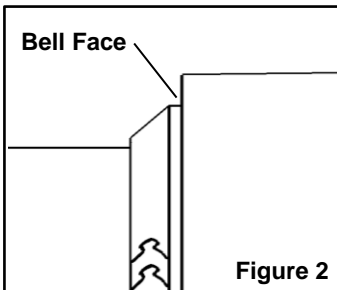

Figure 2

STEP 4

For 16"-24" sizes, the gaskets have a Kee-Lok™ feature allowing the gasket to be adjusted to fit larger diameter Class C-D pipe. Wrap gasket around the spigot pipe and if the ends of the gasket can be snapped together without the Kee-Lok extension piece, the extension piece should be discarded. If the gasket does not reach around the pipe without the Kee-Lok extension piece, it should be used to extend the gasket around the pipe. (Figure 1)

For 30" and 36" sizes, the gaskets are bias cut and partially cut at predetermined lengths to facilitate segment removal. Wrap gasket around the spigot pipe and determine the correct gasket length. Remove any unneeded segment(s) with a sharp knife being careful to maintain the correct bias cut.

Note: A gasket long enough so that the ends easily contact is much better than a short gasket that requires stretching.
Note: The pipe can also be measured with a PI-tape to determine whether or not the Kee-Lok extension piece is needed. See chart on reverse side.

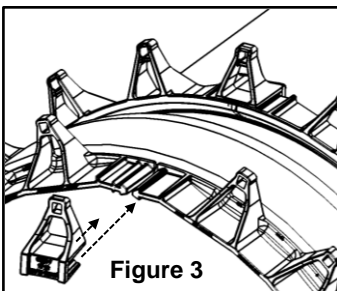

Figure 3

STEP 5

Lubricate the pipe surface and gasket(s) using a soap and water solution (anti-freeze may be required). All lubricant solutions should meet the requirements of the water/gas and pipe supplier. Place the gasket around the pipe with the large vertical flat surface against the bell face. The 30" and 36" gasket should be placed around the pipe with the "BELL FACE" mark against the bell face. (Figure 2)

STEP 6

Assemble the spigot ring adjacent to the gasket. The front side with the angular inner surface should be facing the gasket. The connecting links should be put on the lugs engaging the notches on the ring segments to form the smallest circle that will fit around the pipe. It may be necessary to drive the connector link on with a hammer to obtain a secure connection between link and spigot ring. Care should be taken not to damage the coating. (Figure 3)

Note: The cast ring segments that make up the bell ring and spigot ring are identical and interchangeable. Each segment has two notches on one end and a single notch on the opposite end that mate with lugs in the cast connector links to allow the rings to be assemble at different positions to accommodate either Class A-D pit cast or centrifugally cast iron pipe.

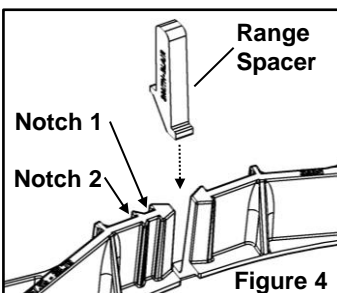

Figure 4

STEP 7

When the connector link lugs are engaged with the second ring segment notch, the ring segment ends will be close enough together to provide a continuous compression surface against the gasket. (Figure 4)

When the connector link lugs are engaged with the first ring segment notch, there will be a gap approximately 5/8" wide between the ends of the ring segments. A cast Range Spacer, should be inserted in this gap with the angular surface on the ring segments to provide a continuous compression surface against the gasket.

STEP 8

Repeat steps 6 through 7 to install the Bell Ring on the backside of the bell. Be sure the cast ring segments' angular surface is facing the bell.

STEP 9

Install bolts and nuts hand tight being sure that all components are in alignment. Nuts should be located on spigot end. Tighten nuts progressively and uniformly to recommended torque value to the right. (Figure 5)

STEP 10

Check for leakage and recheck bolts for proper torque prior to backfilling. If possible, nuts should be checked for tightness 12-24 hours after initial tightening.

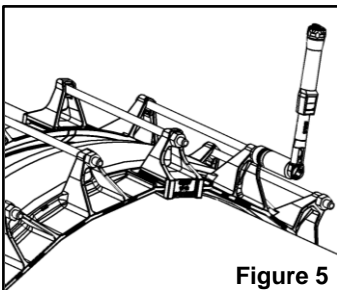

Figure 5

NUT SIZE	TORQUE VALUE
5/8"	60-70 FT. LBS.

Use of a calibrated torque wrench is recommended!

See Reverse Side for Detailed Cut-Away View and Warnings



Smith-Blair
a xylem brand

Installation Instructions

274

Bell Joint Leak Clamp 16" – 36" Sizes

Kee-Lok Guide		
Clamp Catalog Number	Class A & B Cast Iron Pipe O.D. (in)	Class C & D** Cast Iron Pipe O.D.
	DISCARD	USE
274-1740-000	17.40	17.80
274-1950-000	19.50	19.92
274-2160-000	21.60	22.06
274-2580-000	25.80	26.32
*274-3174-000	31.74	32.74
*274-3796-000	37.94	38.70

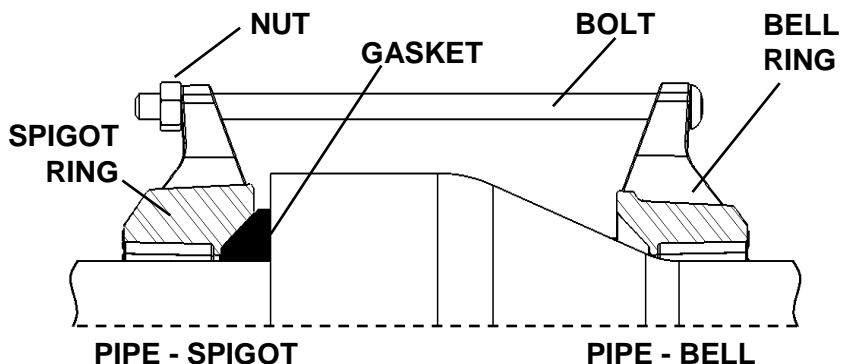

*Available with bias cut gaskets only

** Class "D" not available in 36" size

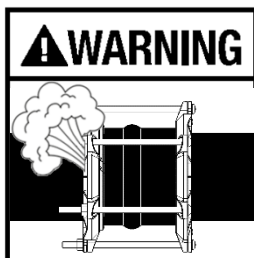

THIS PRODUCT DOES NOT RESTRAIN PIPE MOVEMENT. Proper anchoring is required to prevent pipe pull out. Failure to anchor or improper anchoring can result in dangerous pipe content escape, property damage, serious injury, and/or death. Read the product installation instructions prior to installing this product.

WARRANTY

Smith-Blair, Inc. warrants its products to be free of defects in materials and workmanship for a period of one (1) year from the date of shipment by Smith-Blair, Inc. (the "Warranty Period"). Dated proof of purchase, such as a bill of sale, is required to establish warranty eligibility. If a product fails to perform due to a defect in materials or workmanship during the Warranty Period, Smith-Blair, Inc. will repair or, at Smith Blair, Inc.'s option, replace the product with the same or comparable item. In the event that the product cannot be repaired and a suitable replacement item is not available, Smith-Blair, Inc. will refund the original purchase price shown on the proof of purchase. In all cases, the customer is responsible for returning the allegedly defective product to the factory or warehouse designated by Smith-Blair, Inc.

THIS LIMITED WARRANTY IS EXCLUSIVE AND IS IN LIEU OF ANY EXPRESS OR IMPLIED WARRANTY OF MERCHANTABILITY, FITNESS FOR A PARTICULAR PURPOSE, OR OTHER WARRANTY OF QUALITY, OR THOSE ARISING FROM A COURSE OF DEALING, CUSTOM, OR USAGE OF TRADE. THE REMEDIES PROVIDED IN THIS LIMITED WARRANTY STATEMENT ARE THE CUSTOMER'S SOLE AND EXCLUSIVE REMEDIES. IN NO EVENT SHALL SMITH-BLAIR, INC. BE LIABLE FOR DIRECT, INDIRECT, SPECIAL, INCIDENTAL, OR CONSEQUENTIAL DAMAGES, WHETHER BASED ON CONTRACT, TORT, OR ANY OTHER LEGAL THEORY, AND WHETHER ADVISED OF THE POSSIBILITY OF SUCH DAMAGES.

04/18

CORROSION & PRODUCT SELECTION NOTICE

Metal products are subject to corrosion, particularly when used outdoors and/or underground. A large number of factors and local conditions affect the rate of corrosion. Consult a local corrosion expert to determine the life expectancy of this product when used with your pipeline content, soil, and environment. Also, consult your system designer to determine the suitability of this product in your piping system. Failure to determine the suitability of this product in your application, soil, and/or environment can result in premature product failure. Smith-Blair will provide additional information about this product's material specifications at your request. You may also obtain product information at www.smith-blair.com.

04/18

Installation Instructions

274

Fabricated Model Bell Joint Leak Clamp with Plate Flanges



STEP 1

Inspect the shipment received to ensure no damage has occurred during transit or storage and that no hardware is missing. Ensure the received bell joint leak clamp is the correct size for the installation prior to beginning.

Note: Prior to disassembly, note all orientation marks on flanges and how flanges halves are assembled for reassembly.

STEP 2

Clean pipe joint thoroughly on back of bell, on bell face and on spigot where gasket will seat. Be sure to remove any scale, dirt, or debris that could affect the gasket seal.

STEP 3

Inspect the joint. For caulked joint installations, caulking should be flush with bell face as far as practical. Caulking should not extend beyond bell face. If recessed more than 1/8", it should be faced up with a suitable material. Keep excess material off the spigot and bell face.

STEP 4

Wrap the gasket around the pipe with the beveled side facing away from the bell face as shown below.

STEP 5

Carefully trim any extra gasket length with a sharp knife, being sure to maintain the bias cut angle. The gasket can be held in place by stapling the two ends together using a common office stapler.

STEP 6

Assemble flange halves opposite of Step 1 disassembly on each side of the bell with the beveled gasket-sealing surface facing the bell as shown below. Be sure to align any orientation marks as noted in Step 1.

STEP 7

Install studs and nuts hand tight being sure that all components are in alignment. Tighten nuts progressively and uniformly to suppress the leak.

Note: DO NOT exceed maximum torque values to the right.

NUT SIZE	MAX TORQUE VALUE
5/8"	70 FT. LBS.
3/4"	90 FT. LBS.
1"	120 FT. LBS.

Use of a calibrated torque wrench is recommended!

STEP 7

Check for leakage and recheck bolts for proper torque prior to backfilling. If possible, nuts should be checked for tightness 12-24 hours after initial tightening.

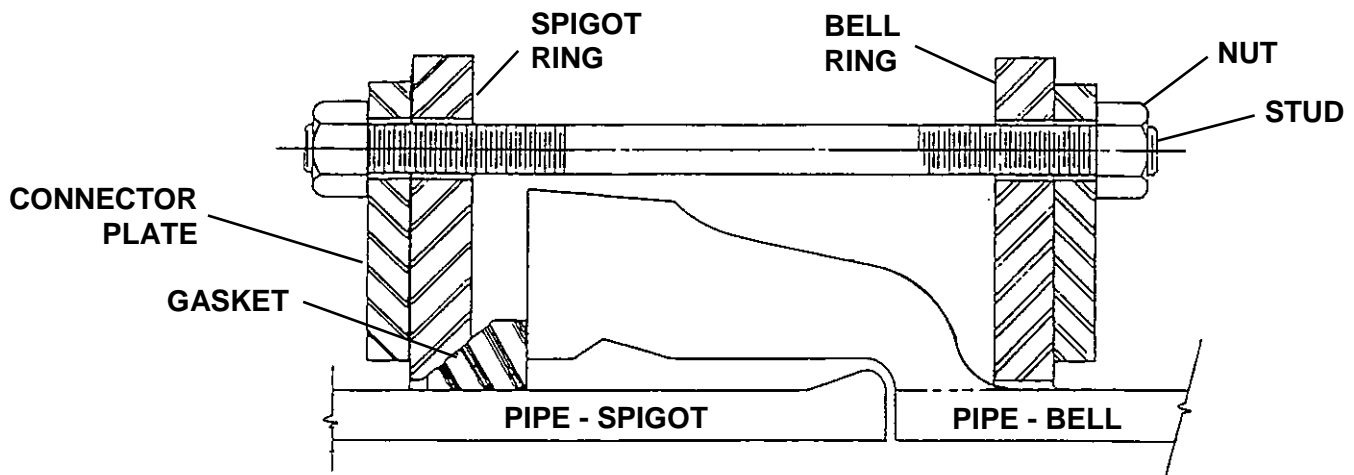



Installation Instructions

274

Fabricated Model Bell Joint Leak Clamp with Plate Flanges

This section was intentionally left blank



36 Hudson Rd
Sudbury MA 01776



800-225-4616
www.tisales.com



THIS PRODUCT DOES NOT RESTRAIN PIPE MOVEMENT. Proper anchoring is required to prevent pipe pull out. Failure to anchor or improper anchoring can result in dangerous pipe content escape, property damage, serious injury, and/or death. Read the product installation instructions prior to installing this product.

WARRANTY

Smith-Blair, Inc. warrants its products to be free of defects in materials and workmanship for a period of one (1) year from the date of shipment by Smith-Blair, Inc. (the "Warranty Period"). Dated proof of purchase, such as a bill of sale, is required to establish warranty eligibility. If a product fails to perform due to a defect in materials or workmanship during the Warranty Period, Smith-Blair, Inc. will repair or, at Smith Blair, Inc.'s option, replace the product with the same or comparable item. In the event that the product cannot be repaired and a suitable replacement item is not available, Smith-Blair, Inc. will refund the original purchase price shown on the proof of purchase. In all cases, the customer is responsible for returning the allegedly defective product to the factory or warehouse designated by Smith-Blair, Inc.

THIS LIMITED WARRANTY IS EXCLUSIVE AND IS IN LIEU OF ANY EXPRESS OR IMPLIED WARRANTY OF MERCHANTABILITY, FITNESS FOR A PARTICULAR PURPOSE, OR OTHER WARRANTY OF QUALITY, OR THOSE ARISING FROM A COURSE OF DEALING, CUSTOM, OR USAGE OF TRADE. THE REMEDIES PROVIDED IN THIS LIMITED WARRANTY STATEMENT ARE THE CUSTOMER'S SOLE AND EXCLUSIVE REMEDIES. IN NO EVENT SHALL SMITH-BLAIR, INC. BE LIABLE FOR DIRECT, INDIRECT, SPECIAL, INCIDENTAL, OR CONSEQUENTIAL DAMAGES, WHETHER BASED ON CONTRACT, TORT, OR ANY OTHER LEGAL THEORY, AND WHETHER ADVISED OF THE POSSIBILITY OF SUCH DAMAGES.

04/18

CORROSION & PRODUCT SELECTION NOTICE

Metal products are subject to corrosion, particularly when used outdoors and/or underground. A large number of factors and local conditions affect the rate of corrosion. Consult a local corrosion expert to determine the life expectancy of this product when used with your pipeline content, soil, and environment. Also, consult your system designer to determine the suitability of this product in your piping system. Failure to determine the suitability of this product in your application, soil, and/or environment can result in premature product failure. Smith-Blair will provide additional information about this product's material specifications at your request. You may also obtain product information at www.smith-blair.com.

04/18