

**AMERICAN AVK HIGH PRESSURE, 250 PSI, MODERN, DRY BARREL HYDRANT 27M/PHH/XMON/NG WITH MONITOR ELBOW - 3MON, 3", 4MON, 4" MONITOR**

Meets or exceeds AWWA C502 (latest) - Working Pressure - 250 PSI

Inlet Bases: Flanged in accordance with ANSI B16.1 Class 125,

Mechanical and Push-On Joint in accordance with ANSI/AWWA C111/A21.11

**Use:**

For water and neutral liquids to maximum 160°F.

**Tests:**

Hydraulic test to AWWA C502:

Seat Test: 500 PSI

**Approvals:**  
UL/ULC Listed,  
FM Approved  
Certified to:  
NSF/ANSI 61  
NSF/ANSI 372



**Components:**

Nozzle Section, Bonnet, Barrels, Standpipe Flanges, Breakable Flange, Main Valve Flange, Base, Monitor Elbow

Caps, Weathershield

Nozzles, Valve Seat Ring, Drain Ring  
Operating Nut, Thrust Nut

Brass Fittings, Brass Plugs

Main Valve

Stem Rod Couplings, Lock Rings, Nozzle Retaining  
Screw, Lock Plate, Lock Plate Screw, Stop Pins,  
Coupler Pins, Main Valve Retaining Pin, Spring Pins,

Coating

Stop Nut, Chain Set, Hardware

Barrel Gasket, Cap Gasket, O-rings

Lubrication Hole Seal

Anti-Friction Washer

Base Elbow / Inlet Configuration

6" MJ

4" MJ

8" MJ\*

**Standard:**

Ductile Iron ASTM A536

Cast Iron ASTM A126 Class "B"

Bronze

Brass

Ductile iron core, fully encapsulated with EPDM rubber.

Stainless Steel

Above ground-Fusion bonded epoxy inside and out. Below ground - Bitumen/Fusion bonded epoxy. Epoxy meets or exceeds AWWA C550 (latest)

Zinc Plated Steel

NBR - ( Barrel Gasket with 304 stainless insert )

Oil Resistant Rubber

Polyamide

6" Flanged

4" Flanged

Straight Flanged 6"

6" Push-on

4" PE\*

6" PE\*

\*Not UL/ULC Listed or FM Approved

**Optional Materials:**

Hardware

Upper Stem Rod

Lower Stem Rod

Opening Direction

Zinc Plated

304 Stainless

304 Stainless

Open Left

304 Stainless

Epoxy Coated Steel

Epoxy Coated Steel

Open Right

316 Stainless

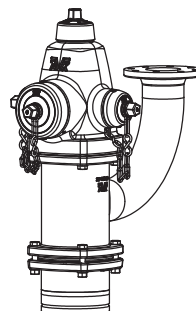

Series 27M/PHH/XMON/NG with Monitor Elbow  
1 Pumper, 2 Hose Outlet



36 Hudson Rd  
Sudbury MA 01776



800-225-4616  
www.tisales.com

**AMERICAN AVK HIGH PRESSURE, 250 PSI, MODERN, DRY BARREL HYDRANT 27M/PHH/XMON/NG WITH MONITOR ELBOW - 3MON, 3", 4MON, 4"** **MONITOR**

Meets or exceeds AWWA C502 (latest) - Working Pressure - 250 PSI

Inlet Bases: Flanged in accordance with ANSI B16.1 Class 125,

Mechanical and Push-On Joint in accordance with ANSI/AWWA C111/A21.11

**Component List:**

- |                               |                                      |  |                                |
|-------------------------------|--------------------------------------|--|--------------------------------|
| 1. Weathershield Bolt         | 21. Hose Nozzle Cap Gasket -Detail A | 37. Breakable Stem Rod Coupling        | 61. Main Valve Disc -Detail B  |
| 2. Weathershield              | 22. Hose Nozzle O-ring - Detail A    | 38. Spring Pin                         | 62. Base Gasket -Detail B      |
| 3. Lock Plate Screw           | 23. Nozzle Retaining Screw           | 41. Lower Stem Rod                     | 67. Base                       |
| 4. Lock Plate                 | 24. Chain Set                        | 44. Extension Bolt -Detail B           | 71. Modern Nozzle Section Bolt |
| 5. Inner Thrust Nut O-ring    | 25. Pumper Nozzle O-ring             | 46. Standpipe Flange -Detail B         | 75. Zerk Fitting               |
| 6. Thrust Nut                 | 26. Pumper Nozzle                    | 49. Lower Barrel                       |                                |
| 7. Outer Thrust Nut O-ring    | 27. Pumper Nozzle Gasket             | 50. Lower Barrel O-ring Detail B       |                                |
| 8. Anti-Friction Washer       | 28. Pumper Nozzle Cap                | 51. Valve Seat Ring -Detail B          |                                |
| 9. Lubrication Hole Seal      | 29. Nozzle Section                   | 53. Valve Seat O-ring -Detail B        |                                |
| 10. Operating Nut             | 30. Nozzle Section Bolt              | 54. Drain Ring -Detail B               |                                |
| 11. Stop Nut                  | 31. Nozzle Section Washer            | 55. Brass Plug -Not shown              |                                |
| 15. Stem Seal O-rings         | 32. Lock Ring                        | 56. Brass Fitting -Not shown           |                                |
| 16. Upper Stem Rod            | 33. Breakable Flange                 | 60. Main Valve Retaining Pin -Detail B |                                |
| 17. Barrel Gasket             | 34. Nozzle Section Nut               |  |                                |
| 19. Hose Nozzle Cap -Detail A | 35. Upper Barrel                     |  |                                |
| 20. Hose Nozzle -Detail A     | 36. Coupler Pin                      |  |                                |

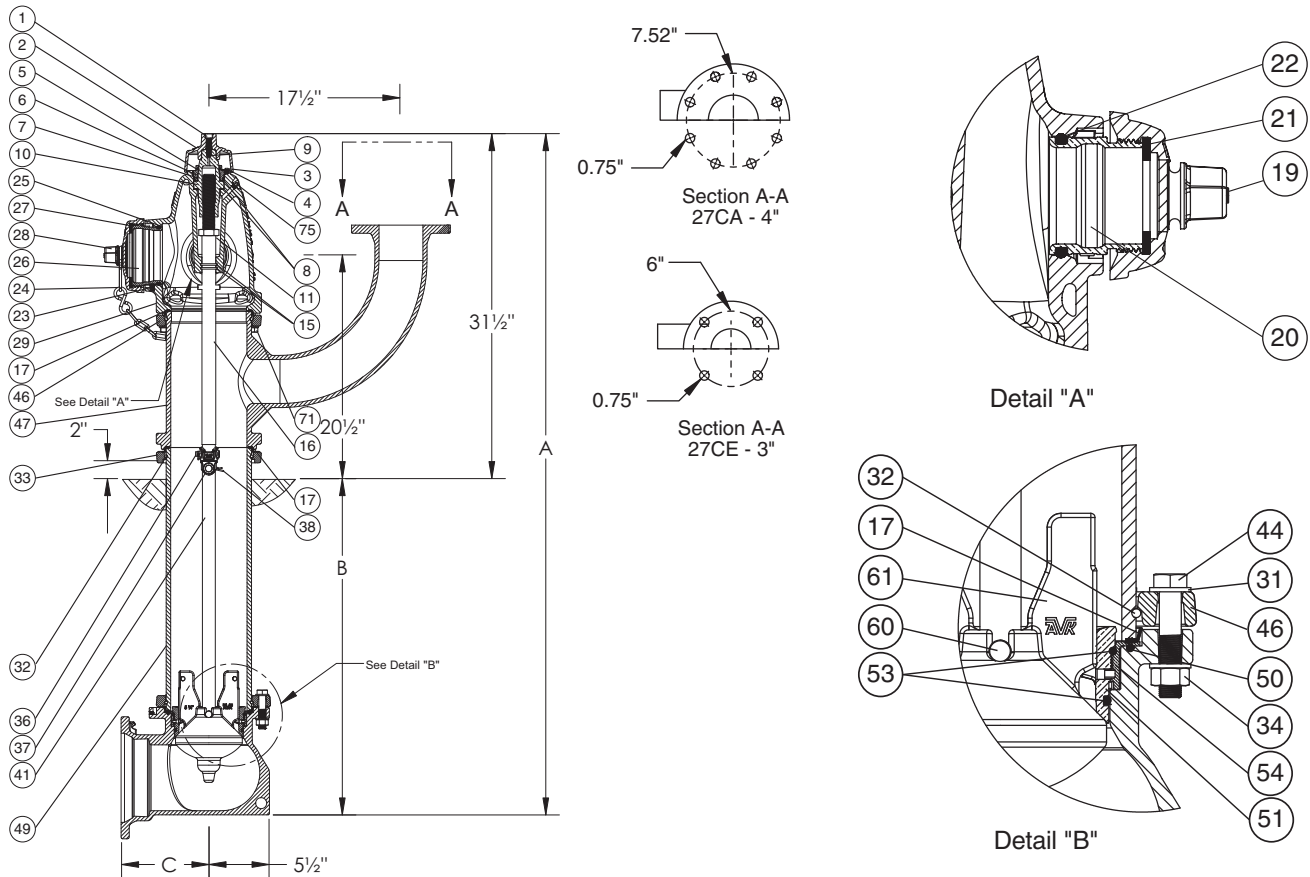

Ref No.*	Base Sizes	Outlets	A	B**	C Flanged	C MJ	C Push-on	C PE
27M-PHH-4-XMON	- 4"	2x2½", 1x4"/4½"	49.50" - 247.50"	18" - 216"	8.00"	8.00"	N/A	23.70"
27M-PHH-6-XMON	- 6"	2x2½", 1x4"/4½"	49.50" - 247.50"	18" - 216"	8.00"	8.00"	9.00"	22.80"
27M-PHH-8-XMON	- 8"	2x2½", 1x4"/4½"	49.50" - 247.50"	18" - 216"	N/A	9.38"	N/A	N/A

\* XMON, X = 3, for 3" monitor flange, 4, for 4" monitor flange

\*\* Buries greater than 216" available upon request.



36 Hudson Rd  
Sudbury MA 01776



800-225-4616  
www.tisales.com