

Model 3000™ Digital Ton Cylinder Scales

- Standard base sizes: 42-1/2" x 24-1/4"
- Net capacity: Up to 2,000 lbs. (907 or 1000 kg)
- High accuracy of $\pm 0.25\%$ of capacity
- Single or multi-channel controllers with easy readability to 0.1 lb. (kg)
- 1 to 6 Bases may be summed together into one indicator
- Readout in pounds or kilograms, gallons or liters

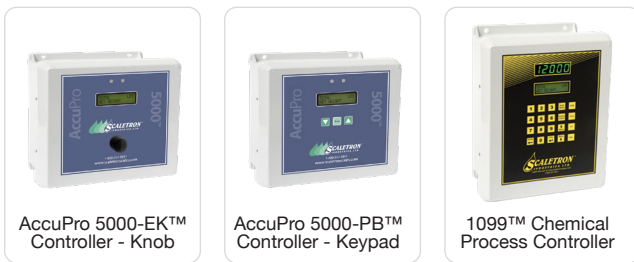
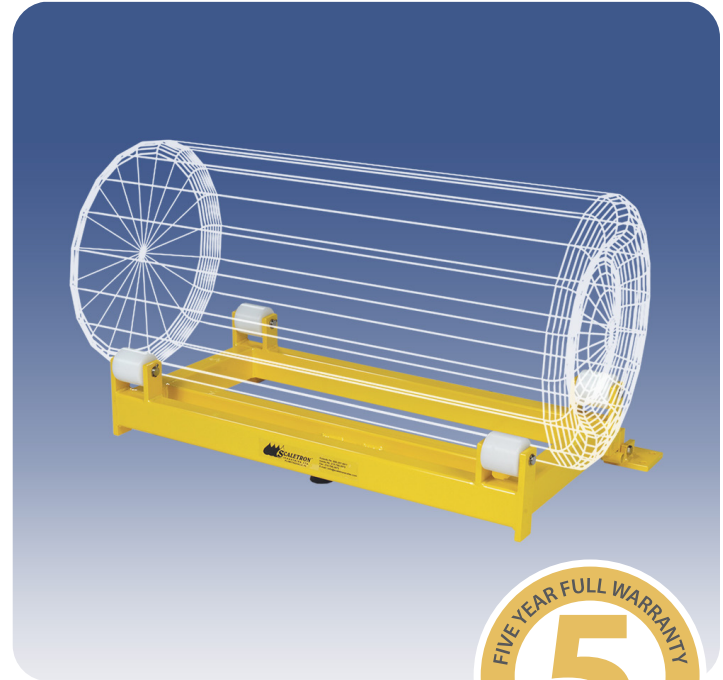

Rugged Scale Provides Accurate Weighing of Ton Containers in High Volume Operations

Model 3000 is designed for weighing standard ton cylinders from 22" to 39" in diameter. Featuring an economical single load cell design, the rugged low-profile base allows for safe and easy handling of containers. MADE IN USA.

Standard Features

- Rugged steel construction protected by a corrosion resistant dry powder epoxy finish
- Low profile platform design (8.63") increases safety and ease of cylinder handling
- Trunnions with solid UHMW polyethylene rollers on stainless steel axles for ease of turning
- NTEP stainless steel shear beam, temperature compensated load cell with built-in mechanical overload stop to protect it from damage during rough cylinder loading
- Electronic indicator housed in NEMA 4X, UL approved enclosure to provide protection from acids
- 20 ft. of 4 conductor wire cable

Available Controllers

- AccuPro 5000 Digital Controller with one or 2 channels, encoder knob or 3 button keypad, audible alarm and 4-20 mA output signal – scale or loop powered
- Model 1099 Chemical Process Controller with 1 to 4 channels, 20 button keypad and 4-20 mA output signal – scale or loop powered

Options

- High and low level set points
- 0-5V or 0-10V output signal
- Remote mounting of indicator box up to 200 feet away
- Cylinder restraining straps

Chemicals

- Scale is designed to accurately measure weight of ammonia, carbon dioxide, hydrogen chloride, liquefied chlorine, sulfur dioxide and other liquid gases

Model 3000™ Digital Ton Cylinder Scale Sizes & Specifications

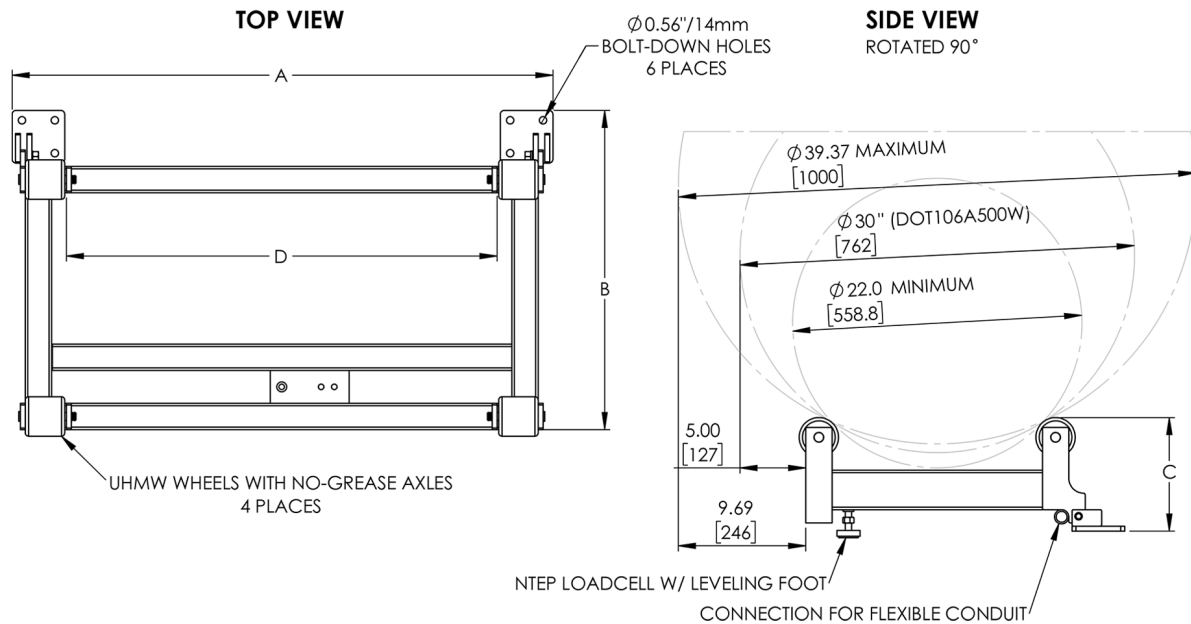

Scale Base

PART NUMBER	3000
Platform Length (A)	41.13" (1045 mm)
Platform Width (B)	24.25" (616 mm)
Platform Height (C)	8.63" (219 mm) from floor to top of 3" UHMW roller
D	32.75" (832 mm)
Net Capacity	Up to 2000 lbs. (907 or 1000 kg) (150% overload protection is provided)
Weight	110 lbs.

Digital Controllers

PART NUMBER	ACCUPRO 5000-EK	ACCUPRO 5000-PB	1099 C.P.C.
Interface	Encoder knob	Keypad with three (3) push buttons	20 Button keypad
Accuracy	±0.1% to ±0.25% of full scale capacity	±0.1% to ±0.25% of full scale capacity	±0.1% to 0.25% of full scale capacity
Display	6 Digit alphanumeric backlit LCD	6 Digit alphanumeric backlit LCD	6 Digit LED & alphanumeric backlit LCD
Display Units	Pounds, kilograms, gallons or liters	Pounds, kilograms, gallons or liters	Pounds, kilograms, gallons or liters
Channels	1 or 2 - One scale base per channel	1 or 2 - One scale base per channel	Up to 4
4-20 mA	4-20mA Standard, 0-5V or 0-10V optional - 1 Output per channel, scale or loop powered	4-20mA Standard, 0-5V or 0-10V optional - 1 Output per channel, scale or loop powered	Standard on channel 1 - Loop powered (available for channels 2 thru 4)
Set Points	2 or 4 Per channel (high or low)	2 or 4 Per channel (high or low)	1 to 4 (high or low)
Remote Mounting	Up to 200 feet from base frame	Up to 200 feet from base frame	Up to 200 feet from base frame
Audible Alarm	Piezo buzzer with adjustable volume	Piezo buzzer with adjustable volume	Optional piezo buzzer with adjustable volume
Power	120/240 VAC, 50/60 Hz, 0.10/0.05A	120/240 VAC, 50/60 Hz, 0.10/0.05A	120/240 VAC, 50/60 Hz, 0.10/0.05A
Enclosure	NEMA 4X, UL approved enclosure	NEMA 4X, UL approved enclosure	NEMA 4X, UL approved enclosure
Weight	7 lbs.	7 lbs.	9 lbs.

Scaleton Industries Ltd.

Bedminster Industrial Park
53 Apple Tree Lane • P.O. Box 365
Plumsteadville, PA 18949 • USA

Tel: (+1) 215-766-2670 (International)
Tel: (+1) 800-257-5911 (USA & Canada)
Fax: (+1) 215-766-2672

Email: info@scaletonscales.com
Website: www.scaletonscales.com