

SPECIFICATION

SERVICE SADDLE SINGLE STRAP

MODEL 315

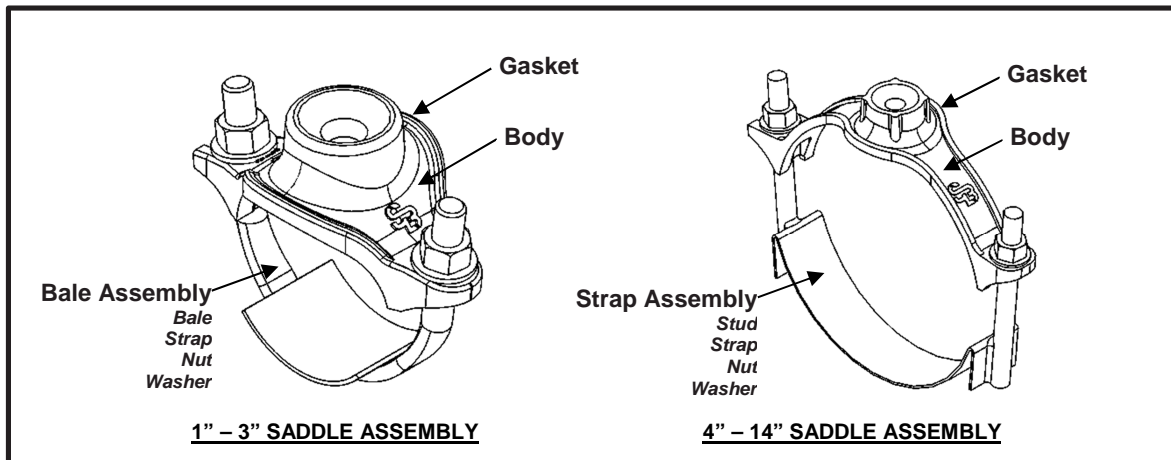

APPLICATIONS

- **Typical Uses**
 - Tapping branch connections on new or existing pipe
 - Installing air/vacuum valves, pitot tubes, drain valves, or other miscellaneous service equipment
 - Installing pipe supports, hangers, or sign mounting brackets
- **Standard Pipe Sizes**
 - 1" to 14" nominal
- **Standard Taps**
 - NPT: 1/2", 3/4", 1", 1-1/4", 1-1/2" and 2"
 - CC/AWWA: 1/2", 5/8", 3/4", 1", 1-1/4", 1-1/2"
 - BSP: 1/2", 3/4", 1", 1-1/4", 1-1/2", 2"

See Smith-Blair catalog for available pipe diameter and tap size combinations as some combinations are not available
- **Type of Pipe**
 - PVC, Carbon Steel, Stainless Steel, Ductile Iron, Asbestos Cement, Aluminum
- **Working Pressure**
 - Up to 200 psi depending on type of pipe, type of repair, pipe diameter, service conditions, and installation workmanship

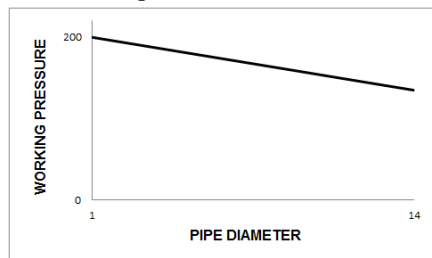

SPECIFICATION

SERVICE SADDLE SINGLE STRAP

MODEL 315

MATERIALS

- **Body**
 - Cast using Ductile Iron 65-45-12 per ASTM A536
 - Flexi-Coat® fusion bonded epoxy finish which meets application methods AWWA C213
 - Closed ear holds nut and bale in place allowing the assembly to hinge for ease of installation around pipe
 - Open ear provides easy slip on installation and removal of nuts are not required preventing lost hardware
 - Canted ears for maximum tangential tightening of bale
 - Wraparound design provides maximum pipe support, reinforcement, and sealing pressure
 - Wide skirt and heavy tapping boss provides excellent stability on the pipe
 - Single strap allows for quick installation
- **Bale Assembly** (*used only on 1" - 3" nominal pipe size saddles*)
 - **Bale**
 - Type 304 Stainless Steel per ASTM A276
 - 1/2"-13UNC
 - Pipe contact surface flattened to provide a wider bearing surface against pipe
 - Rolled threads for improved physical characteristics, greater thread accuracy, and smooth surface finish
 - **Strap**
 - Type 304 Stainless Steel per ASTM A240
 - Formed using 14GA x 2.00" strip and welded to Bale
 - Strap distributes load across a larger surface area preventing damage to non-rigid pipe types
 - Relevant product information placed on strap i.e. O.D. range, part number, etc.
 - **Welding**
 - Welds accomplished using qualified welders
 - GMAW weld process utilized
 - Welds passivated to preserve corrosion resistance
 - **Nut**
 - Type 304 Stainless Steel GR. 8 per ASTM A194
 - Fluoropolymer coated to prevent galling
 - 1/2"-13UNC, Heavy Hex Semi-Finished
 - **Washer**
 - Type 304 Stainless Steel per ASTM A240
 - 1/2" Type A Plain
 - Utilized to preserve corrosion resistance of epoxy coated surfaces and increase bearing surface

SPECIFICATION

SERVICE SADDLE SINGLE STRAP

MODEL 315

- **Strap Assembly** *(used only on 4" – 12" nominal pipe size saddles)*
 - **Strap**
 - Type 304 Stainless Steel per ASTM A240
 - Formed using 14GA x 2.00" strip
 - Strap distributes load across a larger surface area preventing damage to non-rigid pipe types
 - Relevant product information placed on strap i.e. O.D. range, part number, etc.
 - **Stud**
 - Type 304 Stainless Steel per ASTM A276
 - Size: 4" – 6" nominal pipe size = 5/8"-11UNC x 6.00" long, Stud welded to strap
 - 8" – 14" nominal pipe size = 5/8"-11UNC x 7.00" long, Stud welded to strap
 - Rolled threads for improved physical characteristics, greater thread accuracy, and smooth surface finish
 - **Welding**
 - Welds accomplished using qualified welders
 - GMAW weld process utilized
 - Welds passivated to preserve corrosion resistance
 - **Nut**
 - Type 304 Stainless Steel GR. 8 per ASTM A194
 - Fluoropolymer coated to prevent galling
 - 5/8"-11UNC, Heavy Hex Semi-Finished
 - **Washer**
 - Type 304 Stainless Steel per ASTM A240
 - 5/8" Type A Plain
 - Utilized to preserve corrosion resistance of epoxy coated surfaces and increase bearing surface
- **Gasket**
 - Nitrile (Buna-N) per ASTM D2000
 - NSF/ANSI 61 and 372 certified
 - Compounded to resist water, oil, natural gas, acids, alkalies, most (aliphatic) hydrocarbon fluids, and many other chemicals
 - Temperature range: -20°F to +180°F
 - TaperSeal™ hydro-mechanical lip enables the saddle to hold higher pressures with minimal nut torque
 - Gasket is fully cemented in a cavity to hold it in place



SPECIFICATION

SERVICE SADDLE SINGLE STRAP

MODEL 315

LISTINGS

- UL certified to NSF/ANSI 61 and 372
- Meets applicable AWWA C800 standards
- Certain sizes meet Uni-Bell PVC Pipe Associations “Handbook of PVC Pipe” and AWWA M23 Manual “PVC Pipe Design and Installation, when the fitting is ordered with the body properly sized to fit the PVC pipe.

OPTIONS

- Type 316 Stainless Steel bale assembly with fluoropolymer coated nuts to prevent galling
- Type 316 Stainless Steel strap assembly with fluoropolymer coated nuts to prevent galling
- Alternative gasket material (e.g. Viton, EPDM, etc.)
- Anode connector

NOTES

- These product specifications were correct at the time of publication and are subject to change without notice
- Flexi-Coat® is a registered trademark of Smith-Blair, Inc.
- Taperseal™ is a trademark of Smith-Blair, Inc.
- See the Smith-Blair® web site for part numbers and ordering information
- See the Smith-Blair® web site for warranty information
- See the Smith-Blair® web site for corrosion warnings



36 Hudson Rd
Sudbury MA 01776



800-225-4616
www.tisales.com

30 Globe Ave, Texarkana, AR 71854
Ph: 870-773-5127 • Fax: 870-773-5212
Toll-Free Numbers: Ph: 800-643-9705 • Fax: 800-648-6792

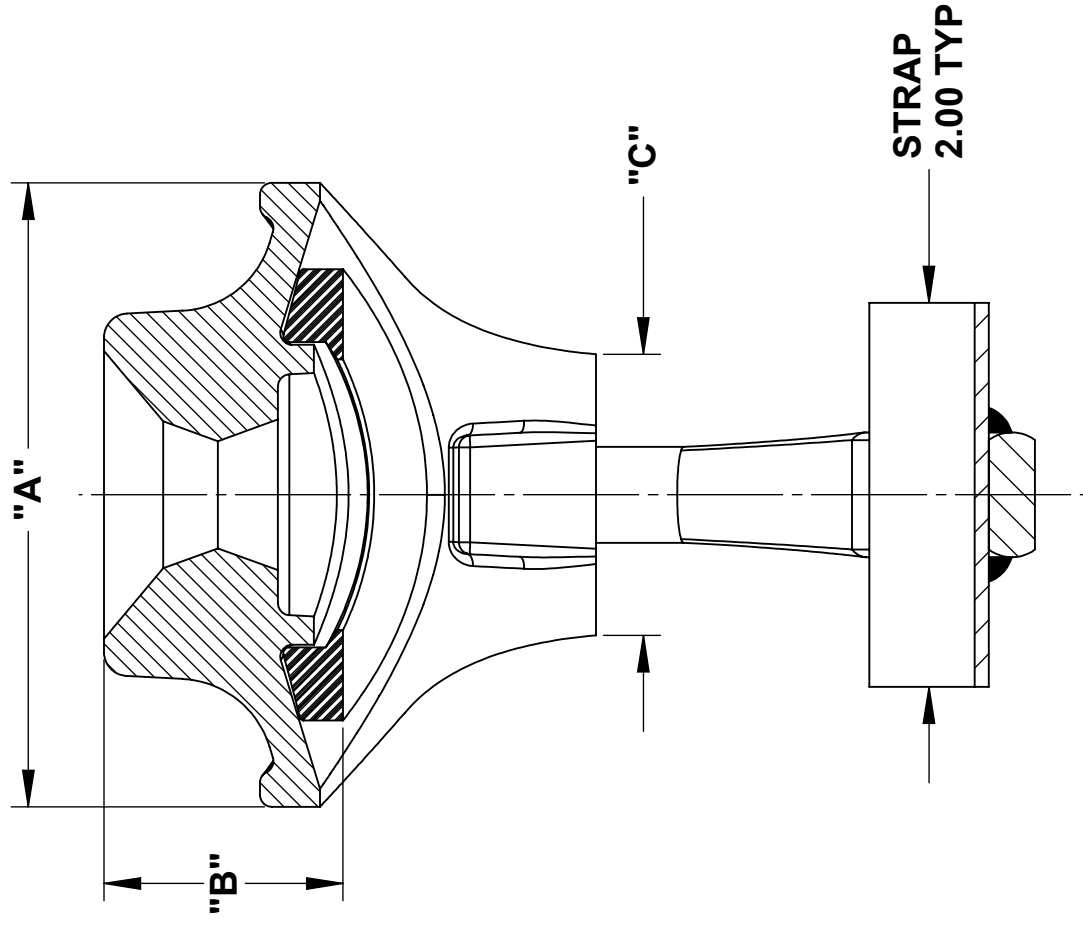
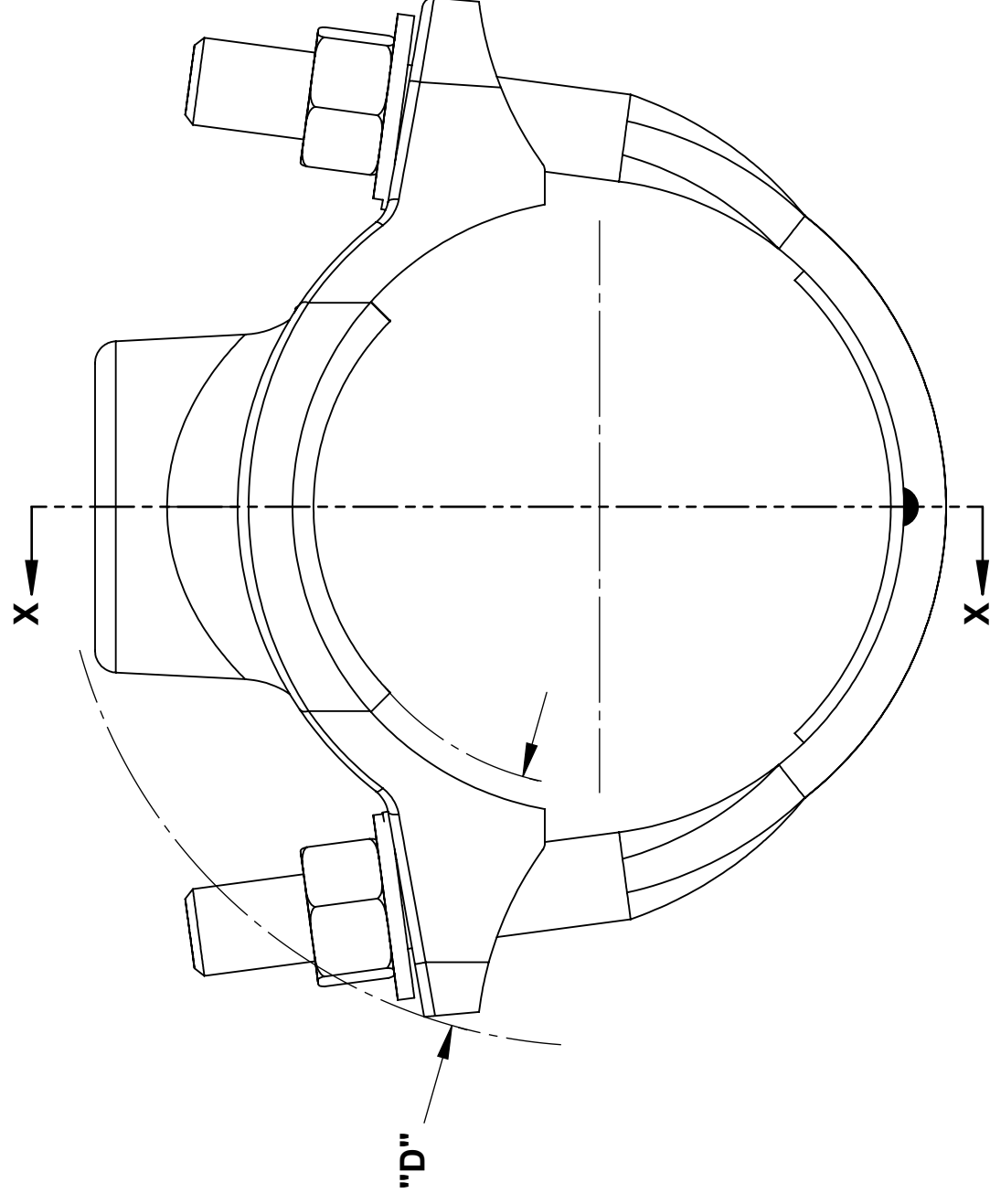

CERTIFIED TO NSF/ANSI 61-G & 372

NOMINAL SIZE	APPROX. WT. (LB)	TAP CODE	A	B	C	D	SOCKET SIZE
1	1	ST	3.35	1.40	1.25	1.55	7/8"
	-	LT	-	-	-	-	
1.25 - 1.50	1	ST	3.35	1.40	1.25	1.55	7/8"
	-	LT	-	-	-	-	
2	2	ST	3.65	1.66	2.70	1.75	7/8"
	2	LT	3.95	1.40	1.25	1.65	
2.25 - 2.50	2	ST	3.40	-	-	-	7/8"
	3	LT	3.90	1.45	1.30	1.50	
3	2	ST	3.40	-	-	-	7/8"
	3	LT	3.85	-	-	-	

- NOTES:**
- SEE SMITH-BLAIR CATALOG FOR AVAILABLE PIPE DIAMETER AND TAP SIZE COMBINATIONS AS SOME COMBINATIONS ARE NOT AVAILABLE
 - 3.54" SADDLE SHOWN OTHER SIZES SIMILAR
 - ABREVIATIONS:
ST = SMALL TAP SIZES 1/2" THRU 1"
LT = LARGE TAP SIZES 1-1/4" THRU 2"

TOLERANCES U.N.O. XX= ±.03 XXX= ±.015 FRACTIONS= ±.015 ANGLES= ±1° MACH. FIN=	NOTES: REMOVE BURRS AND SHARP EDGES DO NOT SCALE DWG.	APP'D	DATE
SCALE: N/A	DRN	CHD	DATE
ALL DIMENSIONS ARE IN INCHES.		DRN	DATE
TITLE		DRN	DATE
SPECIFICATION		CHD	DATE
SERVICE SADDLE SINGLE STRAP		CHD	DATE
MODEL 315		CHD	DATE
SMITH-BLAIR, Inc.		P/N	N/A
TEXARKANA, ARKANSAS		P/N	N/A
SPEC_315.DRW		1	3/8/16
DWG. NO.		2	REV.

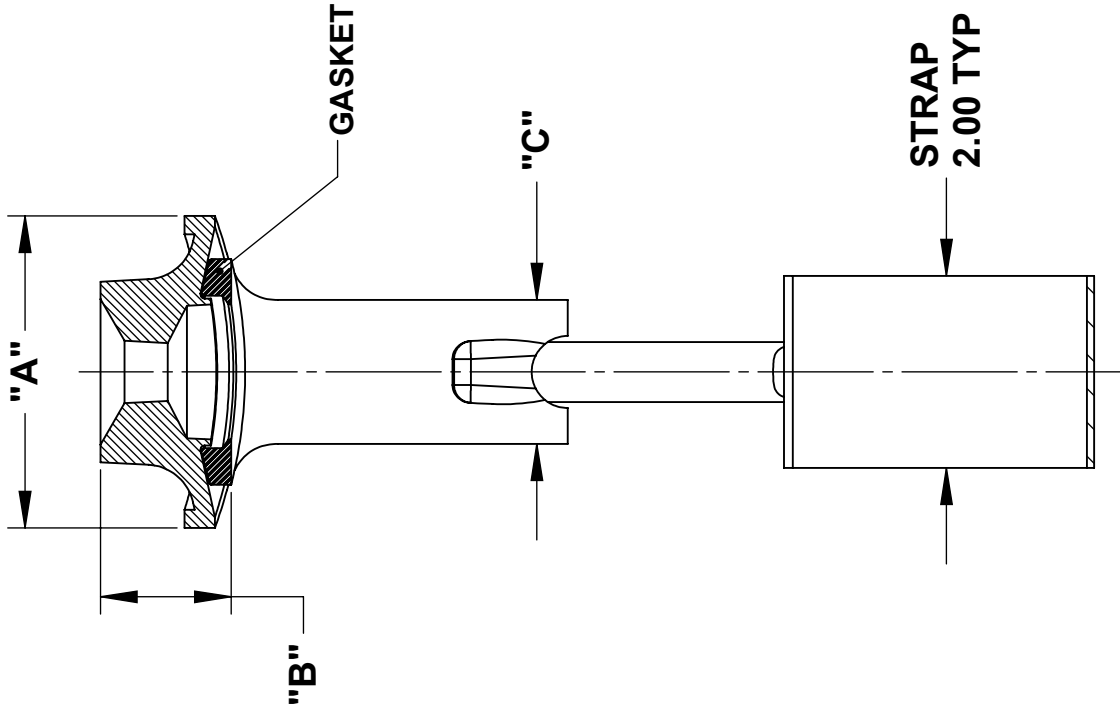

SECTION Y-Y

NOMINAL SIZE	APPROX. WT. (LB)	TAP CODE	A	B	C	D	SOCKET SIZE
4	3	ST	3.45	1.50	1.70	1.80	1-1/16"
	4	LT	4.85				
5	3	ST	3.45	1.50	1.70	1.80	
	5	LT	4.45				
6	5	ST	3.40	1.40	1.70	1.90	
	6	LT	4.40				
8	5	ST	3.40	1.40	1.70	1.90	
	6	LT	4.40				
10	5	ST	3.40	1.40	1.70	1.90	
	6	LT	4.40				
12	5	ST	3.40	1.40	1.70	1.90	
	6	LT	4.40				
14	7	ST	3.40	1.40	1.70	1.90	
	7	LT	4.40				

NOTES:

- SEE SMITH-BLAIR CATALOG FOR AVAILABLE PIPE DIAMETER AND TAP SIZE COMBINATIONS AS SOME COMBINATIONS ARE NOT AVAILABLE
- 9.05" SADDLE SHOWN OTHER SIZES SIMILAR
- ABREVIATIONS:
ST = SMALL TAP SIZES 1/2" THRU 1"
LT = LARGE TAP SIZES 1-1/4" THRU 2"

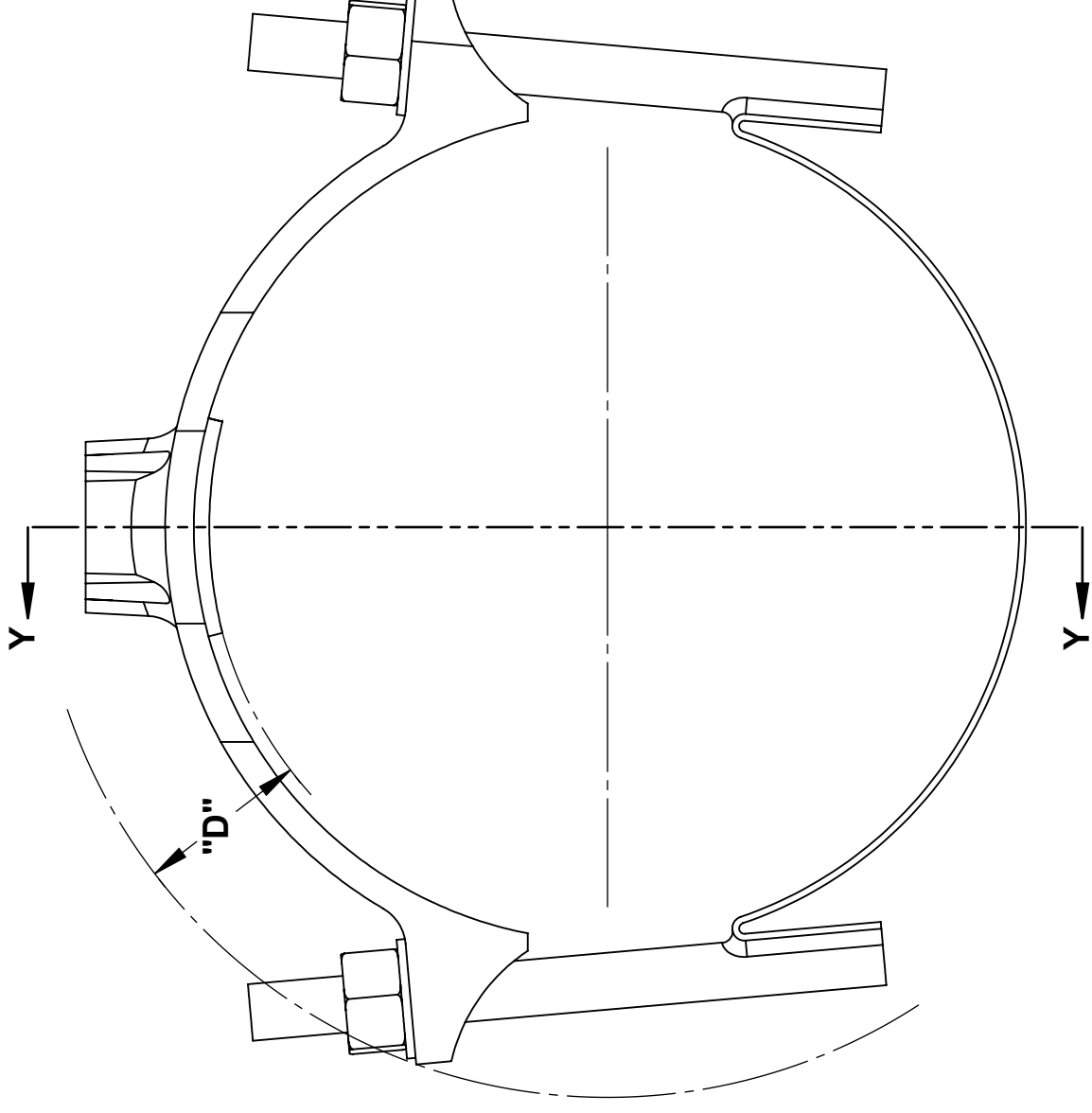

CERTIFIED TO NSF/ANSI 61-G & 372

TOLERANCES U.N.O. XX= ±.03 XXX= ±.015 FRACTIONS= 1/16 ANGLES= 1° MACH. FIN=	APP'D	DATE
	CK'D	DATE
NOTES: REMOVE BURRS AND SHARP EDGES DO NOT SCALE DWG.	SCALE: N/A	DATE: 6/17/15
ALL DIMENSIONS ARE IN INCHES.	DRN	CHD

TITLE

SPECIFICATION
SERVICE SADDLE SINGLE STRAP
MODEL 315

SMITH-BLAIR, Inc. TEXARKANA, ARKANSAS	P/N	N/A
	DWG. NO.	SPEC_315.DRW
	2 OF 2 SHEET	3/8/16 REV.