

# Information Sheet

## Polyethylene Tank and Cover Assembly and Accessories

### MODEL NO. 26350 50 GALLON TANK ASSEMBLY

- Ultraviolet resistant, molded yellow polyethylene tank.
- High rigidity black polyethylene cover with molded recess for mounting of pump, agitator\* and liquid level switch.
- 5 gallon (20 liter) graduations
- Self supporting, tapered sides.
- Suitable for most corrosive and noncorrosive solutions.
- Can be nested up to four ( 4 ) per carton for shipping economy.
- Certified to NSF/ANSI Standard 61 and 372.



Model No. 26350

### COMPONENT PARTS

Ref No.	Part No.	Description	Qty
1	25985	Caplug Assembly Black Polyethylene	1
2	10346	Caplug Assembly Black Polyethylene	2
3*	26637	Cover, Black Polyethylene	1
4	25688	Tank, 50 Gallon Yellow Polyethylene	1

Shipping wt. 25 lbs (11.4 kg)

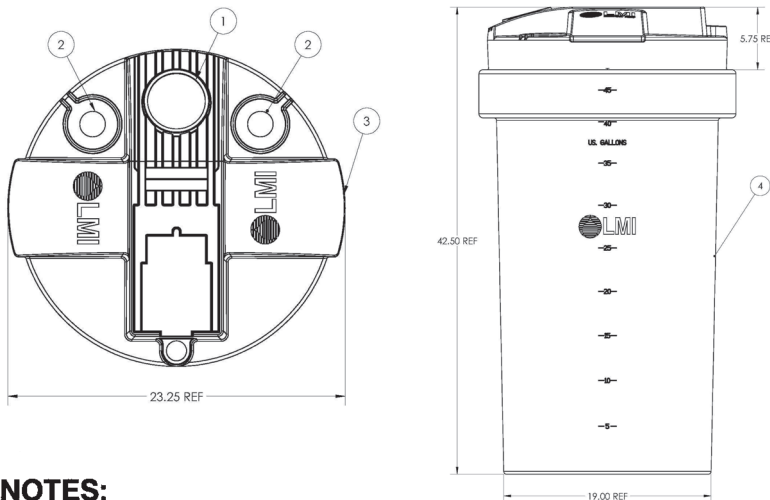

### NOTES:

1. Full, flat bottom support required.
2. Maximum solution/ambient temperature 110°F (43°C)
3. Minimum solution/ambient temperature 0°F (-18°C)
4. Maximum weight limit for cover 50 lbs (23 kg)
5. Not suitable for use with concentrated organic solvents, oils and related materials.

*\*Cover must be drilled at factory for agitator mounting.  
Please indicate your desire for this option when ordering.*



36 Hudson Rd  
Sudbury MA 01776



800-225-4616  
www.tisales.com

201 Ivyland Road  
Ivyland, PA 18974 USA  
TEL: (215) 293-0401  
FAX: (215) 293-0445  
<http://www.lmipumps.com>

## AGITATORS WITH SUCTION TUBE SHIELD

115V Model	Shaft Length	Impeller	Motor
No. 10590	34" S.S. +	303 S.S.+	1600 RPM, 115 VAC, 50/60 Hz., 1.5 AMP. 175 WATTS, 1/20 H.P.
No. 10592	34" S.S. +	Neoprene**	
No. 27591	27" S.S. +	303 S.S.+	

220V Model	Shaft Length	Impeller	Motor
No. 25290	34" S.S.+	303 S.S.+	1600 RPM, 220-240 VAC, 50 Hz., .75 AMP. 175 WATTS 1/20 H.P. DIN Plug
No. 25292	34" S.S.+	Neoprene**	
No. 34504	27" S.S.+	303 S.S.+	

- + *Epoxy chemical resistant coating.*  
 \*\* *Has bronze hub for noncorrosive abrasive slurries only.*

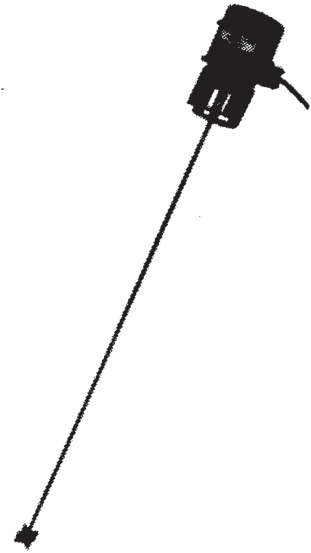

### LIQUID LEVEL SWITCH MODEL NO. 26731

- Corrosion resistant housing of glass - fiber, reinforced polypropylene.
- Chemical resistant polypropylene float.
- Receptacles for connection to metering pump and low level signal device (alarm).
- Convenient mounting on an LMI 50 gallon tank with cover assembly.
- Electrical: Voltage 115 VAC, 50/60 Hz. Max Load: 3 Amps. Also available in 230 VAC, (Model No. 26732).