

# AMERICAN AVK HIGH PRESSURE, 250 PSI, POST, DRY BARREL HYDRANT

**67XX  
POST**

Complies with AWWA C502 (latest) - (where applicable) - Working Pressure - 250 PSI

Inlet Bases: NPT, HYMAX GRIP®, Flanged in accordance with ANSI B16.1 Class 125,

Mechanical Joint in accordance with ANSI/AWWA C111/A21.11

**Use:**

For water and neutral liquids to maximum 160°F.

**Tests:**

Seat Test: 500 PSI

**Approvals:**

Certified to:  
NSF/ANSI 61  
NSF/ANSI 372



**Components:**

Nozzle Section, Barrels, Breakable Flange, Base

Caps, Weathershield

Nozzle, Valve Seat Ring, Main Valve Flange  
Operating Nut, Thrust Nut

Main Valve

Stem Rod Couplings, Upper Stem Rod, Nozzle Retaining Screw,  
Thrust Nut Screw, Coupler Pins, Main Valve Retaining Pin,  
Spring Pins

Coating - Above ground

Coating - Below ground

Chain Set, Hardware

Cap Gasket, O-rings

Anti-Friction Washer

Base Elbow / Inlet Configuration	<input type="checkbox"/> 2" MJ	<input type="checkbox"/> 2.5" Flanged	<input type="checkbox"/> 2" NPT	<input type="checkbox"/> 2" HYMAX GRIP®
	<input type="checkbox"/> 3" MJ	<input type="checkbox"/> 3" Flanged	<input type="checkbox"/> 2.5" NPT	
	<input type="checkbox"/> 4" MJ		<input type="checkbox"/> 3" NPT	

**Standard:**

Ductile Iron ASTM A536

Cast Iron ASTM A126 Class "B"

Bronze

Ductile iron core, fully encapsulated with EPDM rubber.

Stainless Steel

Acrylic Polyurethane paint

Fusion bonded epoxy. Epoxy meets or exceeds AWWA  
C550 (latest)

Zinc Plated Steel

NBR

Brass

**Optional Materials:**

Hardware	<input type="checkbox"/> Zinc Plated (STD)	<input type="checkbox"/> 304 Stainless	<input type="checkbox"/> 316 Stainless
Lower Stem Rod	<input type="checkbox"/> 304 Stainless	<input type="checkbox"/> Steel (STD)	
Opening Direction	<input type="checkbox"/> Open Left	<input type="checkbox"/> Open Right	

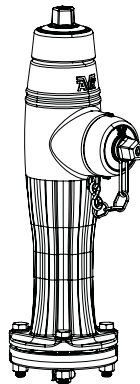

Series 67XX  
1 Hose Outlet



36 Hudson Rd  
Sudbury MA 01776  800-225-4616  
www.tisales.com

# AMERICAN AVK HIGH PRESSURE, 250 PSI, POST, DRY BARREL HYDRANT

**67XX  
POST**

Complies with AWWA C502 (latest) - (where applicable) - Working Pressure - 250 PSI  
Inlet Bases: NPT, HYMAX GRIP®, Flanged in accordance with ANSI B16.1 Class 125,  
Mechanical Joint in accordance with ANSI/AWWA C111/A21.11

## Component List:

1. Weathershield Bolt
2. Weathershield
7. Valve Seat O-ring
19. Hose Nozzle Cap
20. Hose Nozzle
21. Hose Nozzle Cap Gasket
22. Hose Nozzle O-ring
23. Set Screw - (Nozzle)
24. Chain Assembly
31. Nozzle Section Washer
34. Nozzle Section Nut
38. Spring Pin
52. Thrust Nut O-ring
59. Set Screw - (Thrust Nut)
73. Flange O-ring
75. Zerk Fitting
76. Thrust Nut
500. Operating Nut
501. Anti Friction Washer
502. Stem Seal O-ring
503. Upper Stem Rod
504. Nozzle Section
505. Two Piece Breakable Flange
506. Nozzle Section Bolt
507. Coupler Pin
508. Breakable Coupling
509. Lower Barrel
510. Lower Stem Rod
514. Main Valve Flange
515. Seat Ring
516. Main Valve Retainer Pin
517. Cotter Pin
518. Main Valve
519. Base

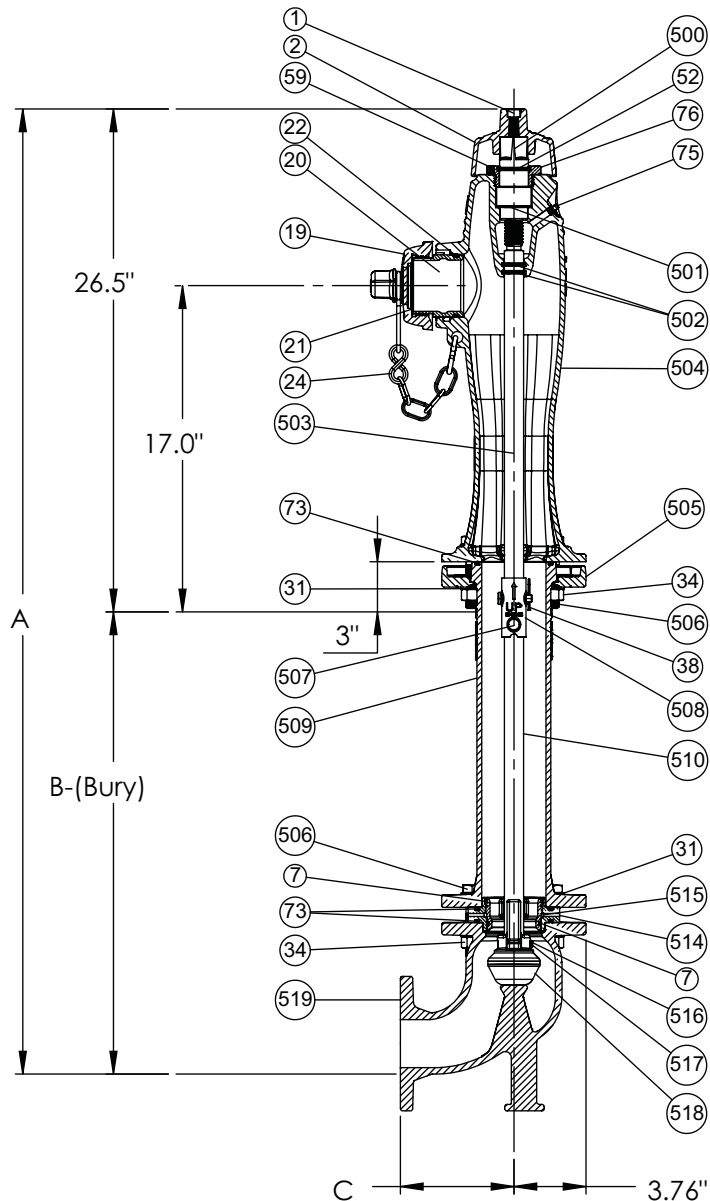

## Notes:

1. F23 - Set Screw for Hose Nozzle, not shown.

Ref No.	A*	B*	C			
			Flanged	MJ	NPT	HYMAX GRIP®
67-XX - 2"	38.50" - 86.50"	12.00" - 60.00"	N/A	6.00"	4.50"	8.26"
67-XX - 2.5"	38.50" - 86.50"	12.00" - 60.00"	6.00"	N/A	5.12"	N/A
67-XX - 3"	38.50" - 86.50"	12.00" - 60.00"	6.00"	7.00"	5.12"	N/A
67-XX - 4"	38.50" - 86.50"	12.00" - 60.00"	N/A	7.00"	N/A	N/A

\* Dimension "A" - 92.50" - 140.50" if using extension barrels, bury depth in 6" increments.

\* Dimension "B" - 66.00" - 114.00" if using extension barrels, bury depth in 6" increments.