



# 1/2"-3" Air/Vacuum Valve Models 100S to 103S

## Operation, Maintenance and Installation Manual

INTRODUCTION.....	1
RECEIVING AND STORAGE.....	1
DESCRIPTION OF OPERATION.....	1
INSTALLATION.....	2
VALVE CONSTRUCTION.....	2
MAINTENANCE.....	2
TROUBLESHOOTING.....	3
DISASSEMBLY.....	3
REASSEMBLY.....	3
PARTS & SERVICE.....	4
WARRANTY.....	4



VAL-MATIC® VALVE AND MANUFACTURING CORP.

905 Riverside Dr. • Elmhurst, IL 60126  
Phone (630) 941-7600 • Fax (630) 941-8042  
www.valmatic.com

# VAL-MATIC'S ½"-3" AIR/VACUUM VALVE OPERATION, MAINTENANCE AND INSTALLATION

## INTRODUCTION

The Air/Vacuum Valve has been designed with stainless steel trim to give years of trouble-free operation. This manual will provide you with the information to properly install and maintain the valve to ensure a long service life. The Air/Vacuum valve is designed to exhaust large quantities of air upon system start-up and allow air to re-enter the line upon system shut down.

**Note:** While Air/Vacuum Valves will exhaust large quantities of air upon start-up, they will not continuously release air during system operation. For that function, an Air Release Valve is required.

Also, this valve is not intended for fluids containing suspended solids such as wastewater. For waste-water and other high turbidity applications, use Val-Matic Series 300A Sewage Air/Vacuum Valves.

**CAUTION**  
This valve is not intended for fuel service  
or fluids containing suspended solids.

The valve is a float-operated, resilient-seated valve designed to handle clean fluids. The Size, Maximum Working Pressure, and Series No. are stamped on the nameplate for reference.

**Note:** Low Durometer seats are available for low pressure applications.

## RECEIVING AND STORAGE

Inspect valves upon receipt for damage in shipment. Unload all valves carefully to the ground without dropping.

Valves should remain crated, clean and dry until installed to prevent weather related damage. For long term storage greater than six months, the rubber surfaces of the seat should be coated with a thin film of FDA approved grease. Do not expose seat to sunlight or ozone for any extended period.

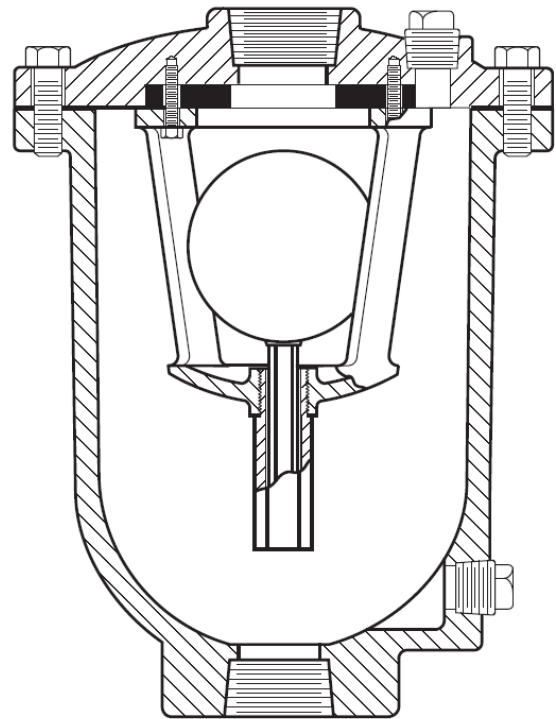

FIGURE 1. ½"-3" AIR/VACUUM VALVE

## DESCRIPTION OF OPERATION

The Air/Vacuum Valve is designed to exhaust large quantities of air upon system start-up and allow air to re-enter the line upon system shut-down or line break. As water enters the valve during start-up, the float will rise, closing the outlet port. The valve will remain closed until system pressure drops to near zero pressure. It will open during shut-down to perform a dual purpose. First, it eliminates the possibility of a vacuum forming and a potential pipeline collapse. Second it allows rapid drainage of the line when system maintenance is required.

### DESCRIPTION OF OPERATION (Cont'd)

The only moving parts in the valve are the float and the float guide. The float guide assures that the float enters the seat at the optimum angle and assures that the float will not make contact with any surface other than the resilient seat thus assuring long maintenance free life.

### INSTALLATION

The installation of the valve is important for its proper operation. Valves must be installed at the system high points in the vertical position with the inlet down. A vault with adequate venting and drainage should be provided. A full-ported shut-off valve should be installed below each valve in the event servicing is required.

### VALVE CONSTRUCTION

The Air/Vacuum Valve body and cover are cast iron. All internal components are stainless steel with the exception of the valve seat which is resilient. The float (5) and float guide (20) are the only moving parts assuring long life with minimal maintenance. The general details of construction are illustrated in Figure 2. The body (1) is threaded for connection to the pipeline. The seat (4) is retained in the cast cover (2). The seat (4) is retained by a baffle (3).

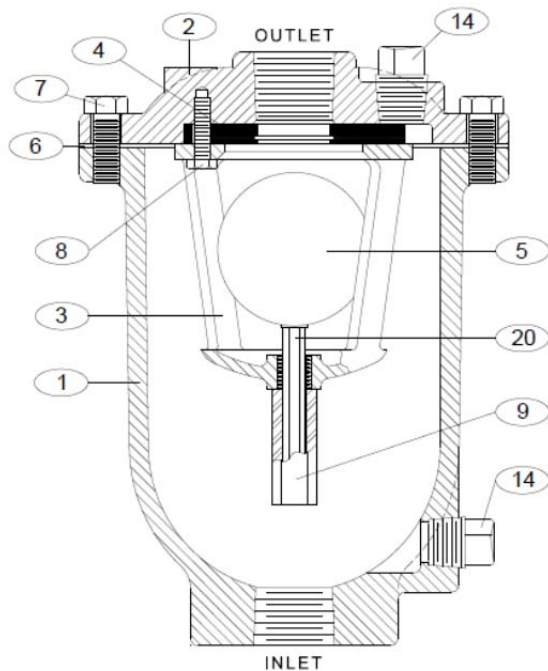

FIGURE 2. 1/2"-3" AIR/VACUUM VALVE

Item	Description	Material
1	Body	Cast Iron
2	Cover	Cast Iron
3	Baffle	Ductile Iron
4	Seat*	Buna-N
5	Float*	Stainless Steel
6	Gasket*	Non-Asbestos
7	Cover Bolt	Alloy Steel
8	Retaining Screw*	Stainless Steel
9	Guide Bushing*	Stainless Steel
14	Pipe Plug	Iron
20	Guide Shaft*	Stainless Steel

\* Recommended Spare Part

### MAINTENANCE

The Air/Vacuum Valve requires no scheduled lubrication or maintenance.

INSPECTION: Periodic inspection for leakage can be performed. A manual drain valve can be installed in the lower drain plug to perform this operation as shown in Figure 3.

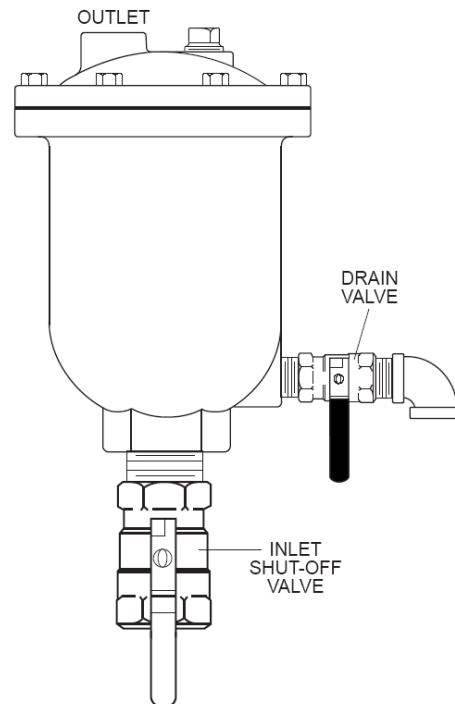

FIGURE 3. INSPECTION PIPING

## MAINTENANCE (Cont'd)

1. Close the inlet shut-off valve.
2. Open the drain valve to allow the fluid in the valve to drain. It may be necessary to apply a downward force on the float to unseat the valve.
3. Close the drain valve.
4. Slowly open the inlet shut-off valve to fill the valve with water. Observe the seating action and verify that the valve closes without leakage.
5. If leakage occurs, the valve should be removed and inspected for wear or possible damage from foreign matter.

## TROUBLESHOOTING

Several problems and solutions are presented below to assist you in troubleshooting the valve assembly in an efficient manner.

- Leakage at Bottom Connection: Tighten valve threaded connection. If leak persists, remove valve and seal threads with Teflon sealant.
- Leakage at Cover: Tighten bolts, replace gasket.
- Valve Leaks when Closed: Inspect seat for damage and replace.

## DISASSEMBLY

The valve can be disassembled without removing it from the pipeline. Or for convenience, the valve can be removed from the line. All work on the valve should be performed by a skilled mechanic with proper tools.

**WARNING**  
The line must be drained before removing the cover or pressure may be released causing bodily harm.

1. Close inlet shut-off valve. Open drain valve or remove drain plug. Remove the cover bolts (7) on the top cover.
2. Pry cover (2) loose and lift off valve body.
3. Remove retainer bolts (8) and inspect seat for cracks in rubber or wear in sealing surface.
4. Turn guide bushing (9) to remove it from the cast baffle (3).
5. Clean and inspect parts. Replace worn parts as necessary.

## RE-ASSEMBLY

All parts must be cleaned and gasket surfaces should be cleaned with a stiff wire brush in the direction of the serrations or machine marks. Worn parts, gaskets and seals should be replaced during reassembly.

1. Apply Loctite to guide bushing threads (9) and thread bushing into baffle (3). Insert float shaft into float (5).
2. Lay seat (4) over inverted cover with flat surface directed toward cover.
3. Install float assembly and baffle over seat and secure with retaining bolts (8) at 10 ft-lbs.
4. Lay cover gasket (6) and cover (2) over bolt holes in body (1).
5. Insert lubricated bolts (7) and tighten to the torques listed in Table 2.

<b>Size</b>	<b>Torque (ft-lbs)</b>
5/16"	10
3/8"	24
1/2"	59
5/8"	117

## PARTS AND SERVICE

Parts and service are available from your local representative or the factory. Make note of the valve Size, Series No, and Serial No. located on the valve nameplate and contact:

Val-Matic Valve and Mfg. Corp.  
905 Riverside Drive  
Elmhurst, IL 60126  
Phone: (630) 941-7600  
Fax: (630) 941-8042  
[www.valmatic.com](http://www.valmatic.com)

A sales representative will quote prices for parts or arrange for service as needed.



36 Hudson Rd  
Sudbury MA 01776



800-225-4616  
[www.tisales.com](http://www.tisales.com)

### LIMITED WARRANTY

All products are warranted to be free of defects in material and workmanship for a period of one year from the date of shipment, subject to the limitations below.

If the purchaser believes a product is defective, the purchaser shall: (a) Notify the manufacturer, state the alleged defect and request permission to return the product; (b) if permission is given, return the product with transportation prepaid. If the product is accepted for return and found to be defective, the manufacturer will, at his discretion, either repair or replace the product, f.o.b. factory, within 60 days of receipt, or refund the purchase price. Other than to repair, replace or refund as described above, purchaser agrees that manufacturer shall not be liable for any loss, costs, expenses or damages of any kind arising out of the product, its use, installation or replacement, labeling, instructions, information or technical data of any kind, description of product use, sample or model, warnings or lack of any of the foregoing. NO OTHER WARRANTIES, WRITTEN OR ORAL, EXPRESS OR IMPLIED, INCLUDING THE WARRANTIES OF FITNESS FOR A PARTICULAR PURPOSE AND MERCHANTABILITY, ARE MADE OR AUTHORIZED. NO AFFIRMATION OF FACT, PROMISE, DESCRIPTION OF PRODUCT OF USE OR SAMPLE OR MODEL SHALL CREATE ANY WARRANTY FROM MANUFACTURER, UNLESS SIGNED BY THE PRESIDENT OF THE MANUFACTURER. These products are not manufactured, sold or intended for personal, family or household purposes.



**VAL-MATIC® VALVE AND MANUFACTURING CORP.**

905 Riverside Dr. • Elmhurst, IL 60126  
Phone (630) 941-7600 • Fax (630) 941-8042  
[www.valmatic.com](http://www.valmatic.com)