

VALMATIC®

Ti SALES

36 Hudson Rd
Sudbury MA 01776



800-225-4616
www.tisales.com



**Air Valves
& VaultSafe®
Family of Products**



www.valmatic.com

Meets AWWA C512 & C514
NSF 61 & 372 Certified

Features & Benefits

Experience

Val-Matic offers over 50 years of experience in providing a full line of air valves up to 20 inch and vacuum breakers up to 42 inch in size. The Val-Matic Air Release, Air/Vacuum and Combination Air Valves are manufactured in accordance to the rigorous industry requirements given in American Waterworks Association (AWWA) Standard C512. The standard was developed and based on decades of successful applications of air valves in our industry. Val-Matic's AWWA Air Valves feature 316 stainless steel trim, full size ports, ANSI threaded or flanged connections and stringent testing. From the float material to the shape of the body, Val-Matic Air Valves are designed for optimum performance. Val-Matic manufactures air valves in a wide range of materials and pressure ratings with many accessories including Regulated-Exhaust Devices, Dual Port Throttling Devices, Isolation Valves, Screened Hoods and Backwash Accessories. Val-Matic also provides web-based software to locate, select and size air valves for pipelines and force mains.

Type 316 Stainless Steel Trim

Type 316 stainless steel is the standard for all internal components in Val-Matic Air Valves. Type 316 stainless steel provides the greatest protection from aggressive waters and hydrogen sulfide exposure in wastewater applications.

Unconditionally Guaranteed Floats

Floats are unconditionally guaranteed for the life of the valve from corrosion, collapse or leakage. Val-Matic has such confidence in the design and manufacturing of our floats that we are able to provide this unconditional guarantee.

Guided Floats

Providing a quality float is not enough to ensure a reliable seal every time. When entering the seat, a damaged or off-center float will prevent a valve from sealing tight. The high air and water velocities in air valves can cause unguided floats to violently strike the sides of the valve body. Val-Matic air/vacuum floats are guided with hexagonal stems in round bushings to prevent the build-up of debris or scale. Guiding assures

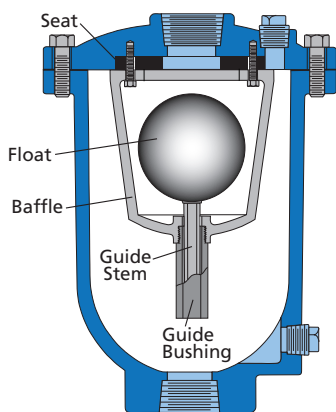

that the float approaches the center of the seat every time to provide a positive drop tight seal.

Resilient Seats

All Val-Matic valves incorporate a resilient seat or orifice button which mates with a 316 stainless steel float or seat for positive drip tight seating. Val-Matic elastomers are specially formulated for water and wastewater service and have been NSF 61 certified. Air Release Valves have a synthetic sealing button mounted to the float linkage mechanism. On Air/Vacuum and Combination Air Valves, the stainless steel float closes against the resilient seat mechanically retained in a cover register. The seats contain raised sealing beads that provide positive shutoff from the lowest system pressure to the valve's rated working pressure.

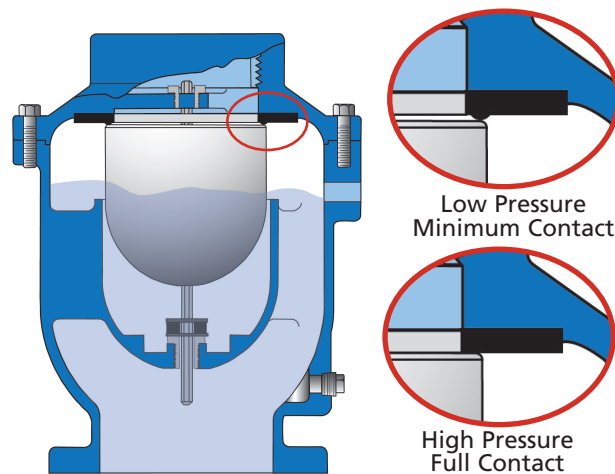

Pressure Sensitive Seating with Raised Sealing Beads

Full Size Flow Area

Val-Matic Air/Vacuum and Combination Air Valves are equipped with full and equal size inlets and outlets in accordance with AWWA C512. Some air valve manufacturers use common covers for different size air valves resulting in undersized outlets and reduced flow. Standard industry calculations assume a full port size so the air valve should provide the same. You can be assured that the inlets and outlets of Val-Matic's Air Valves are equal to or larger than the area of the nominal valve size. Finally, all Combination Air Valves with float guides in the outlet have expanded flow areas around the guide spokes to provide full flow area through the valve.

Certifications

Val-Matic Air Valves for water service are NSF 61 and 372 certified and marked for use in drinking water applications. All Air Valves meet AWWA C512 requirements.

Wastewater Air Valve Features & Benefits

Stainless Steel Body

Seamless stainless steel bodies are lightweight and available for extreme service such as hydrogen sulfide, industrial chemicals or corrosive environments. ASTM A351, Grade CF8M stainless steel bodies provide superior corrosion resistance in full compliance with AWWA C512.

Non-Stick Coatings

Special interior coatings are available to minimize the buildup of sewage on the inside of the valve. Val-Matic's Fusion Bonded Epoxy is a baked-on, glass-like coating that reduces maintenance and prevents corrosion of the valve. Non-stick coatings are important when force mains contain grease that tends to collect in valves and pipes.

Non-Clog Design for Reduced Maintenance

Val-Matic Wastewater Air Valves are specially designed for grit and sewage service without the need for backwashing when combined with non-stick coatings. The bodies are extended in length to prevent solid material from reaching the operating mechanism. The bottom of the body is sloped toward the outlet to prevent clogging. Val-Matic provides a minimum 2 inch inlet size and a 2 inch cleanout connection on all wastewater valves to facilitate the passage of solids.

Wastewater Floats

As with all Val-Matic Air Valves, the float and operating mechanism are 316 stainless steel for long life in the harshest wastewater applications. Additionally, the floats are equipped with a concave or skirted shaped bottom to accelerate the closure of the float to reduce leakage and clogging of the valve.

Severe Service Backwashing

When systems are heavy in grease and solids, backwashing of Wastewater Air Valves may become a necessary maintenance process. The key is to reduce the frequency of backwashing by designing the valve to handle conditions such as wastewater containing solids and grease. As indicated in the above features, Val-Matic has done that with the extended and bell shaped body, the sensitivity float and the availability of non-stick Fusion Bonded Epoxy. Periodic maintenance may still be required on severe applications, therefore, all Wastewater Air Valves can be furnished with an accessory kit which includes a shutoff valve to isolate the air valves from the line, flush and drain valves, and a hose for connecting to a clean water supply.

Backwashing is as simple as: 1) closing the isolation valve, 2) opening the drain valve, and 3) sending clean water through the flush valve and outlet for five minutes.

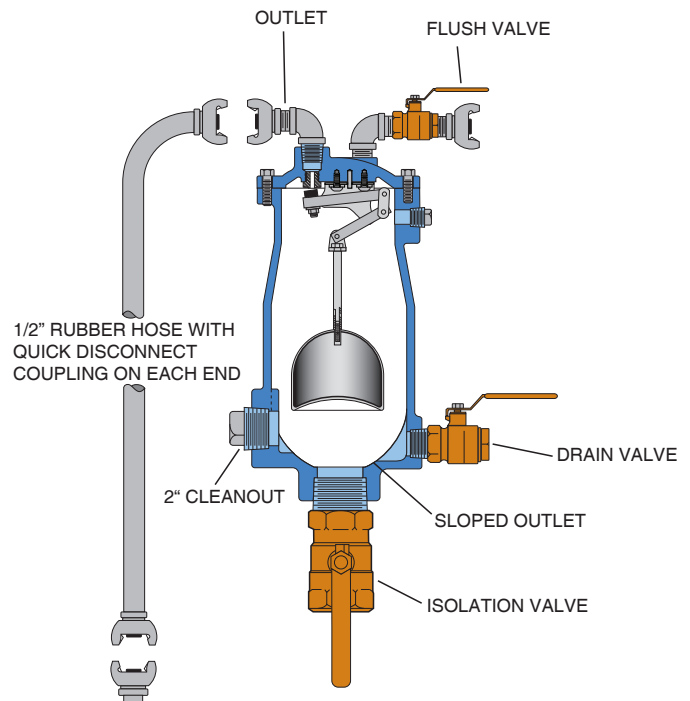

Air Valve with Severe Service Backwash Accessories

For those installations where backwashing on site is not practical or desirable, a valve rotation program can be established. The valve to be serviced is exchanged with a spare valve and taken back to the shop for cleaning. It is then ready to replace the next valve scheduled for maintenance. The valve rotation program also provides the benefit of a backup valve in the unlikely event one should ever fail.

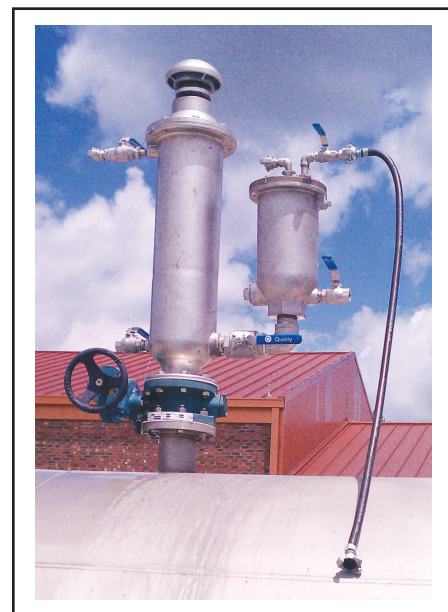

Stainless Steel Dual Body Wastewater Combination Air Valve

Air Release Valves



Operational Highlights:

- Maintains system flow efficiency
- Releases unwanted air pockets during system operation
- Protects system against air related surges
- Fully complies with AWWA C512

Product Features:

- Unconditionally guaranteed stainless steel floats
- Stainless steel 316 internal trim
- Resilient seating for positive shutoff
- Performance proven for over 50 years
- Non-clog design minimizes need for backwashing

Optional Accessories:

- Vacuum check (prevents inflow of air)
- Outlet hood with screen (prevents debris from entering valves)
- Ball and plug isolation valves (allows valve maintenance)
- Inflow Preventer on outlet (stops flood water and resulting contamination from entering pipeline)
- Backwash kit (for severe wastewater applications)

MATERIALS OF CONSTRUCTION		
COMPONENT	STANDARD	OPTIONAL
Body and Cover	Cast Iron ASTM A126 Class B Ductile Iron ASTM A536 Grade 65-45-12	Carbon Steel ASTM A216 Grade WCB Stainless Steel ASTM A351 Grade CF8M
Float and Trim	Type 316 Stainless Steel	—————
Seal	Buna-N	EPDM or Viton
Coating	Universal Acrylic Primer (external)	Non-Stick Fusion Bonded Epoxy (internal & external)

VENTING CAPACITY OF AIR RELEASE VALVE ORIFICES

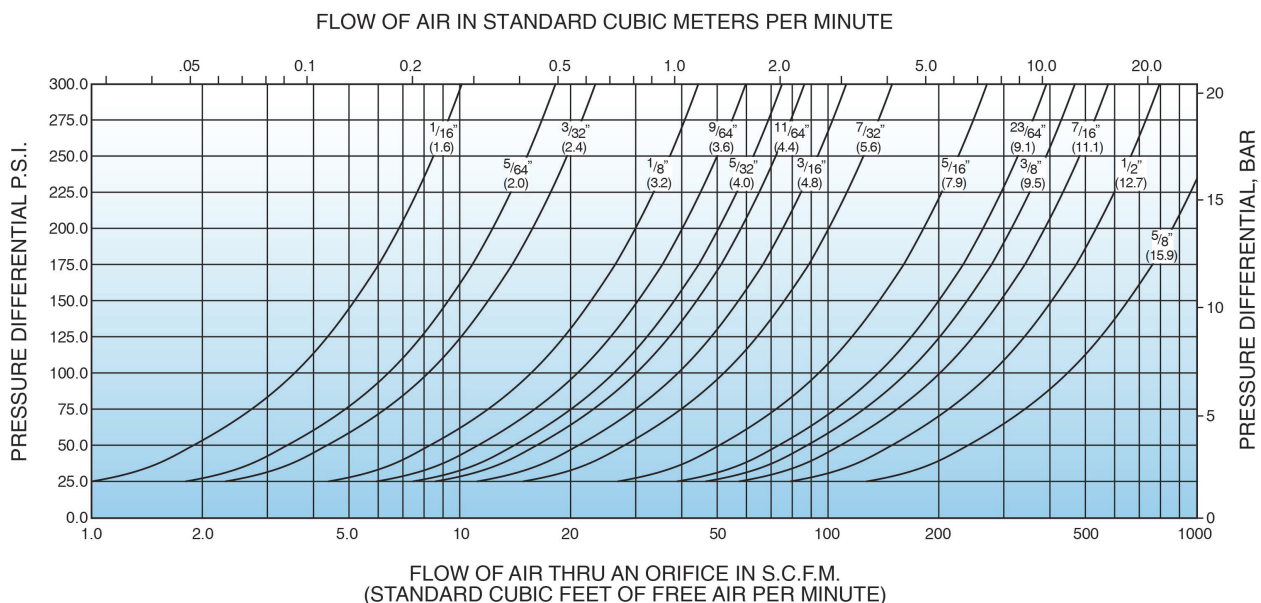

Air Release Valves

WATER AIR RELEASE VALVES						
Inlet Size	Outlet Size	Model Number*	CWP PSI	Orifice Size	Dimensions (Inches)	
					A	B
1/2" NPT	1/2" NPT	15A†	175	1/16"	4.75	5.25
3/4" NPT	1/2" NPT	15A.2†	175	1/16"	4.75	5.25
1" NPT	1/2" NPT	15A.3†	175	1/16"	4.75	5.25
1" NPT	1/2" NPT	22.3†	175	3/32"	5.13	6.31
1/2" - 3/4" NPT	1/2" NPT	22.4†	175	3/32"	5.13	6.31
1/2" NPT	1/2" NPT	22.7†	300	1/16"	5.13	6.31
3/4" - 1" NPT	1/2" NPT	22.9	300	1/16"	5.13	6.31
3/4" - 1" NPT	1/2" NPT	25.5	150	1/8"	6.13	7.00
3/4" - 1" NPT	1/2" NPT	25.6	300	3/32"	6.13	7.00
1" NPT	1/2" NPT	38	150	3/16"	7.00	10.00
2" NPT	1/2" NPT	38.2	150	3/16"	7.00	10.00
1" NPT	1/2" NPT	38HP	500	1/8"	7.00	10.00
2" NPT	1/2" NPT	38HP.2	500	1/8"	7.00	10.00
1" NPT	1/2" NPT	38.5	300	5/32"	7.00	10.00
2" NPT	1/2" NPT	38.6	300	5/32"	7.00	10.00
2" NPT	1" NPT	45	150	23/64"	9.50	12.25
3" NPT	1" NPT	45.2	150	23/64"	9.50	12.25
2" NPT	1" NPT	45HP	400	3/16"	9.50	12.25
3" NPT	1" NPT	45HP.2	400	23/64"	9.50	12.25
2" NPT	1" NPT	45.5	300	7/32"	9.50	12.25
3" NPT	1" NPT	45.6	300	7/32"	9.50	12.25
2" NPT	1" NPT	50	500	7/32"	10.88	13.06
2" NPT	1" NPT	50HP	1000	1/8"	10.88	13.06
6" 125lb Flg	1" NPT	61	150	1"	19.63	22.06

*NSF 61 & 372 Certified †UL Listed/FM Approved

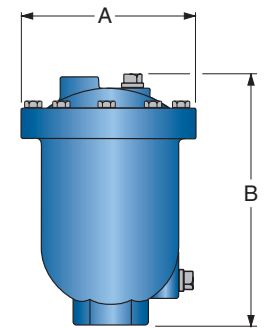

**15A - 50HP
Air Release Valve**

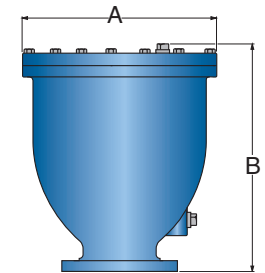

**61
Air Release Valve**

WASTEWATER AIR RELEASE VALVES						
Inlet Size	Outlet Size	Model Number	CWP PSI	Orifice Size	Dimensions (Inches)	
					A	B
2" NPT	1/2" NPT	48A	150	3/16"	7.00	15.31
3" NPT	1/2" NPT	48A.2	150	3/16"	7.00	15.31
2" NPT	1/2" NPT	48A.4	75	5/16"	7.00	15.31
3" NPT	1/2" NPT	48A.5	75	5/16"	7.00	15.31
4" NPT	1/2" NPT	48A.6	75	5/16"	7.00	15.31
2" NPT	1" NPT	49A	150	7/16"	9.50	17.56
3" NPT	1" NPT	49A.2	150	7/16"	9.50	17.56
2" NPT	1" NPT	49A.4	75	1/2"	9.50	17.56
3" NPT	1" NPT	49A.5	75	1/2"	9.50	17.56
4" NPT	1" NPT	49A.6	75	1/2"	9.50	17.56

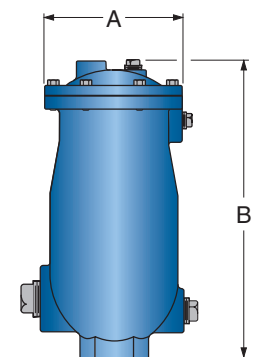

**48A - 49A.6
Wastewater Air
Release Valves**

Air/Vacuum Valves



Clean Water



Wastewater

Operational Highlights:

- Exhausts large quantities of air at system start-up
- Provides pipeline vacuum protection
- Responds to loss of pressure during power failures, line breaks and intentional drainage
- Fully complies with AWWA C512

Product Features:

- Unconditionally guaranteed stainless steel floats
- Stainless steel 316 internal trim
- Exclusive high/low pressure resilient seating
- Full pipe size inlets and outlets provide maximum protection
- Non-clog design minimizes need for backwashing

Optional Accessories:

- Outlet hood with screen (prevents debris from entering valves)
- Flanged outlets on sizes 8 inch & smaller
- Ball and plug isolation valves (allows valve maintenance)
- Inflow Preventer on outlet (stops flood water and resulting contamination from entering pipeline)
- Backwash kit (for severe wastewater applications)

MATERIALS OF CONSTRUCTION		
COMPONENT	STANDARD	OPTIONAL
Body, Cover and Baffle	Cast Iron ASTM A126 Class B Class 125 and 250 Ductile Iron ASTM A536 Grade 65-45-12	Carbon Steel ASTM A216 Grade WCB Stainless Steel ASTM A351 Grade CF8M
Trim	Type 316 Stainless Steel	—————
Seal	Buna-N	EPDM or Viton
Coating	Universal Acrylic Primer (external)	Non-Stick Fusion Bonded Epoxy (internal & external)

VENTING CAPACITY OF AIR/VACUUM VALVE ORIFICES

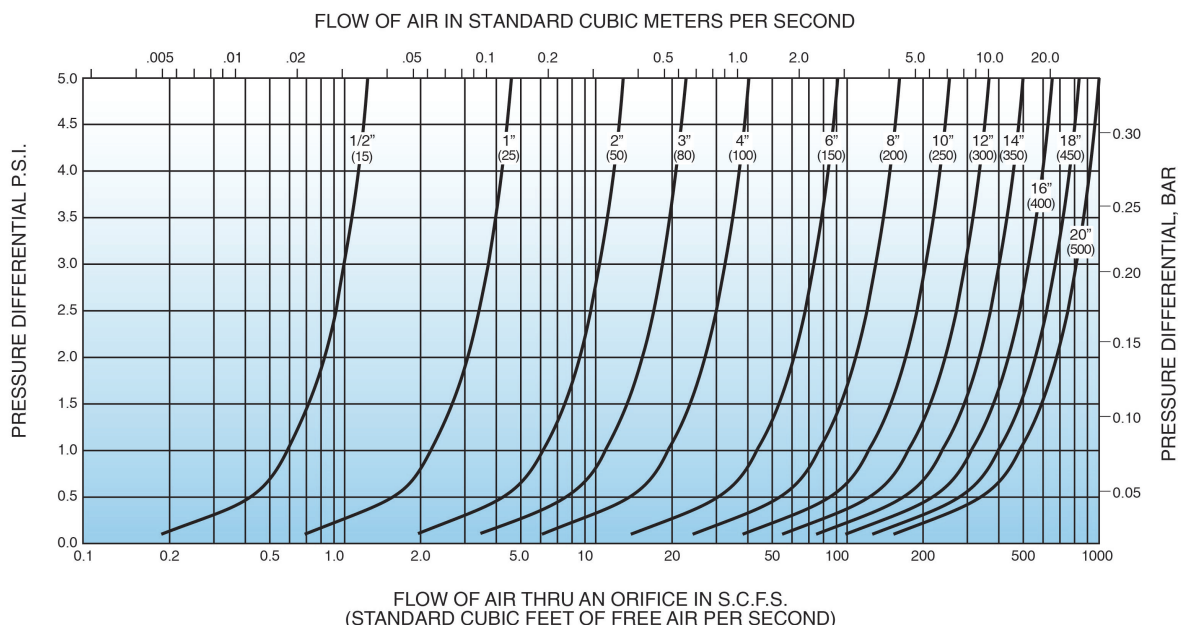

Air/Vacuum Valves

WATER AIR/VACUUM VALVES					
Inlet Size	Outlet Size	Model Number*	CWP PSI	Dimensions (Inches)	
				A	B
1/2" NPT	1/2" NPT	100S	300	6.13	7.00
1" NPT	1" NPT	101S	300	7.00	9.68
2" NPT	2" NPT	102S	300	9.50	12.00
3" NPT	3" NPT	103S	300	9.50	12.00
4" Flg	4" NPT	104S 154S	125lb - 150 250lb - 300	11.50	16.38
6" Flg	6" NPT	106S 156S	125lb - 150 250lb - 300	14.00	18.63
8" Flg	8" NPT	108S 158S	125lb - 150 250lb - 300	17.25	21.63
10" Flg	10" Flg	110F 160F	125lb - 150 250lb - 300	20.25	24.50
12" Flg	12" Flg	112F 162F	125lb - 150 250lb - 300	24.00	30.00
14" Flg	14" Flg	114F 164F	125lb - 150 250lb - 300	27.00	29.50
16" Flg	16" Flg	116F 166F	125lb - 150 250lb - 300	30.50	35.19
20" Flg	20" Flg	120F 170F	125lb - 150 250lb - 300	38.25	42.06

*NSF 61 & 372 Certified

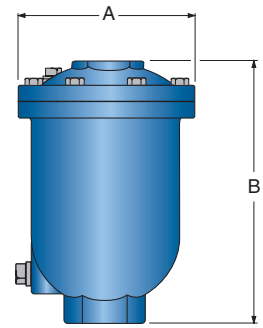

100S - 103S
Air/Vacuum Valves

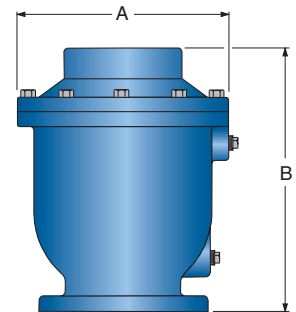

104S - 170F
Air/Vacuum Valves

WASTEWATER AIR/VACUUM VALVES					
Inlet Size	Outlet Size	Model Number	CWP PSI	Dimensions (Inches)	
				A	B
2" NPT	1" NPT	301A	150	7.00	15.06
2" NPT	2" NPT	302A	150	9.50	17.44
3" NPT	3" NPT	303A	150	9.50	17.44
4" Flg	4" NPT	304	150	11.50	36.63
6" Flg	6" NPT	306	150	14.00	36.38
8" Flg	8" NPT	308	150	17.25	40.13

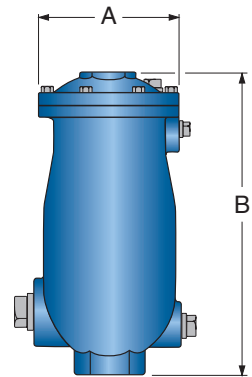

301A - 308
Wastewater Air/Vacuum Valves

Combination Air Valves



Clean Water



Wastewater

Operational Highlights:

- Provides the functions of both Air Release and Air/Vacuum Valves
- Exhausts large quantities of air at system start-up
- Releases air pockets during system operation
- Provides pipeline vacuum protection
- Fully complies with AWWA C512

Product Features:

- Single body incorporates both features within one valve
 - More compact and economical
- Dual body consists of two independent valves
 - Allows individual maintenance while still protecting the pipeline
 - Wider range of sizing options
- Inlets and outlets are equal to full nominal size
- Unconditionally guaranteed stainless steel floats
- Stainless steel 316 internal trim
- Non-clog design minimizes need for backwashing
- Exclusive high/low pressure resilient seating

Optional Accessories:

- Outlet hood with screen (prevents debris from entering valves)
- Ball, plug and butterfly isolation valves (allows valve maintenance)
- Inflow Preventer on outlet (stops flood water and resulting contamination from entering pipeline)
- Backwash kit (for severe wastewater applications)

MATERIALS OF CONSTRUCTION		
COMPONENT	STANDARD	OPTIONAL
Body, Cover and Baffle	Cast Iron ASTM A126 Class B Class 125 and 250	Ductile Iron ASTM A536 Grade 65-45-12 Stainless Steel ASTM A351 Grade CF8M
Trim	Type 316 Stainless Steel	—————
Seal	Buna-N	EPDM or Viton
Coating	Universal Acrylic Primer (external)	Non-Stick Fusion Bonded Epoxy (internal & external)

VENTING CAPACITY OF COMBINATION AIR VALVE ORIFICES

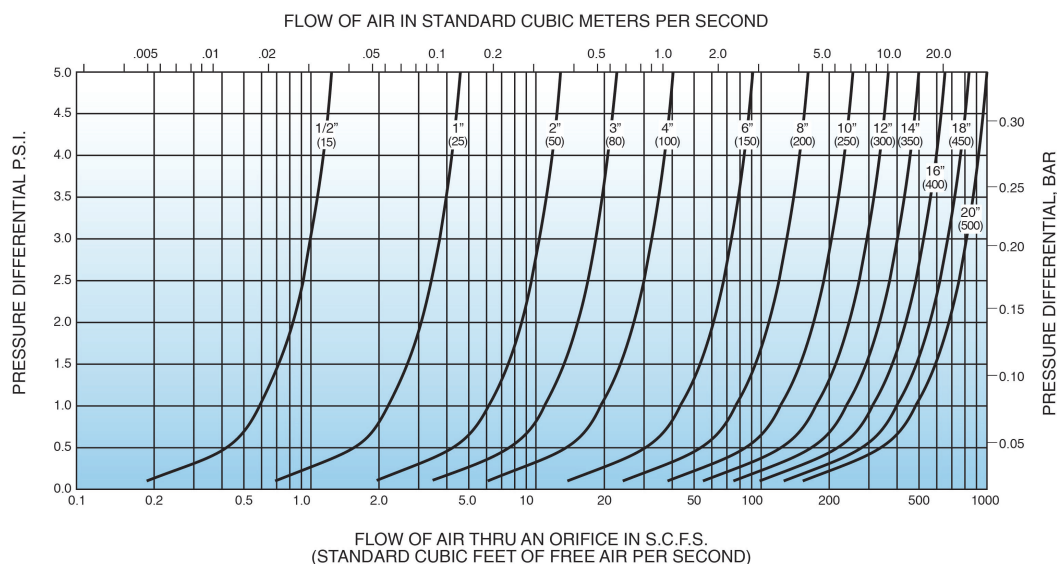

Combination Air Valves

WATER COMBINATION AIR VALVES (SINGLE BODY)						
Inlet Size	Outlet Size	Model Number*	CWP PSI	Orifice Size	Dimensions (Inches)	
					A	B
1" NPT	1" NPT	201C.2	300	5/64"	11.38	10.50
2" NPT	2" NPT	202C.2	300	3/32"	14.00	13.00
3" NPT	3" NPT	203C.2	300	3/32"	16.00	15.00
3" 125lb Flg	3" NPT	203C.14	150	3/32"	16.00	16.75
3" 250lb Flg	3" NPT	203C.15	300	3/32"	16.00	17.25
4" 125lb Flg	4" NPT	204C.14	150	3/32"	18.50	19.00
4" 250lb Flg	4" NPT	204C.15	300	3/32"	18.50	20.25
6" 125lb Flg	6" NPT	206C	150	3/8"	21.00	20.25
6" 250lb Flg	6" NPT	256C	300	7/32"	21.00	20.25
8" 125lb Flg	8" NPT	208C	150	3/8"	25.00	23.50
8" 250lb Flg	8" NPT	258C	300	7/32"	25.00	23.50

*NSF 61 & 372 Certified

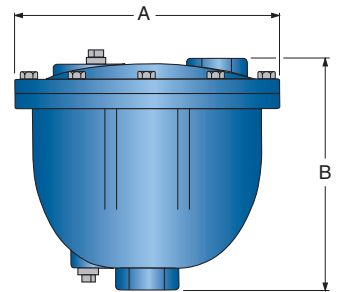

201C.2 - 204C.15
Single Body Combination Air Valves

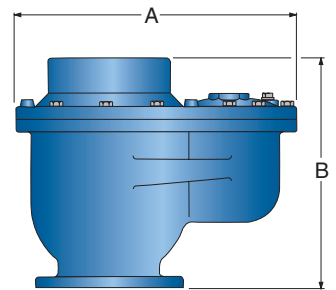

206C - 258C
Single Body Combination Air Valves

WASTEWATER COMBINATION AIR VALVES (SINGLE BODY)						
Inlet Size	Outlet Size	Model Number	CWP PSI	Orifice Size	Dimensions (Inches)	
					A	B
2" NPT	1" NPT	801A	150	1/8"	7.00	14.94
2" NPT	2" NPT	802A	150	9/64"	9.50	18.06
3" NPT	3" NPT	803A	150	11/64"	11.00	19.20
4" NPT	4" NPT	804	150	11/64"	11.00	23.50

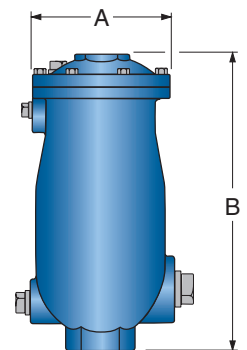

801A - 804
Wastewater Single Body Combination Air Valves

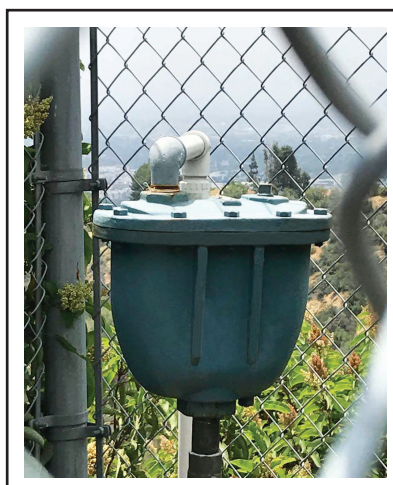

Single Body Combination Air Valve



Single Body Combination Air Valve with FloodSafe® Inflow Preventer

Combination Air Valves

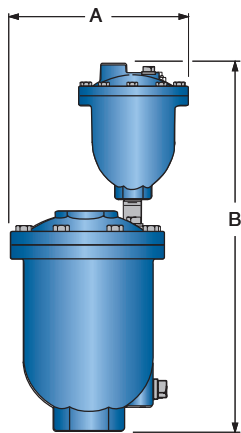

101S/22.9 - 103S/22.9
Dual Body Combination
Air Valves

WATER COMBINATION AIR VALVES (DUAL BODY)						
Inlet Size	Outlet Size	Model Number*	CWP PSI	Orifice Size	Dimensions (Inches)	
					A	B
1" NPT	1" NPT	101S/22.9	300	1/16"	7.81	15.75
2" NPT	2" NPT	102S/22.9	300	1/16"	10.25	18.00
3" NPT	3" NPT	103S/22.9	300	1/16"	10.25	18.00

*NSF 61 & 372 Certified

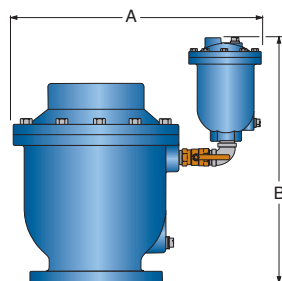

104S/38 - 166F/45.5
Dual Body Combination
Air Valves

WATER COMBINATION AIR VALVES (DUAL BODY)						
Inlet Size	Outlet Size Air/Vacuum	Model Number*	CWP PSI	Orifice Size Air Release	Dimensions (Inches)	
					A	B
4" Flg	4" NPT	104S/38 154S/38.5	125lb - 150 250lb - 300	3/16" 5/32"	19.50	21.50
6" Flg	6" NPT	106S/38 156S/38.5	125lb - 150 250lb - 300	3/16" 5/32"	22.00	23.25
8" Flg	8" NPT	108S/38 158S/38.5	125lb - 150 250lb - 300	3/16" 5/32"	25.25	25.25
8" Flg	8" NPT	108S/45 158S/45.5	125lb - 150 250lb - 300	23/64" 7/32"	29.19	28.69
10" Flg	10" Flg	110F/38 160F/38.5	125lb - 150 250lb - 300	3/16" 5/32"	28.19	27.19
10" Flg	10" Flg	110F/45 160F/45.5	125lb - 150 250lb - 300	23/64" 7/32"	32.19	30.44
12" Flg	12" Flg	112F/38 162F/38.5	125lb - 150 250lb - 300	3/16" 5/32"	31.91	30.44
12" Flg	12" Flg	112F/45 162F/45.5	125lb - 150 250lb - 300	23/64" 7/32"	35.94	33.69
14" Flg	14" Flg	114F/38 164F/38.5	125lb - 150 250lb - 300	3/16" 5/32"	34.91	30.37
14" Flg	14" Flg	114F/45 164F/45.5	125lb - 150 250lb - 300	23/64" 7/32"	38.94	33.63
16" Flg	16" Flg	116F/38 166F/38.5	125lb - 150 250lb - 300	3/16" 5/32"	38.41	32.69
16" Flg	16" Flg	116F/45 166F/45.5	125lb - 150 250lb - 300	23/64" 7/32"	42.44	35.94

*NSF 61 & 372 Certified

Combination Air Valves

WASTEWATER COMBINATION AIR VALVES (DUAL BODY)						
Inlet Size	Outlet Size	Model Number	CWP PSI	Orifice Size	Dimensions (Inches)	
					A	B
2" NPT	1" NPT	48A/301A	150	3/16"	25.80	20.20
2" NPT	1" NPT	49A/301A	150	7/16"	27.00	22.50
2" NPT	2" NPT	48A/302A	150	3/16"	27.00	20.20
2" NPT	2" NPT	49A/302A	150	7/16"	28.30	22.50
3" NPT	3" NPT	48A/303A	150	3/16"	34.00	21.00
3" NPT	3" NPT	49A/303A	150	7/16"	35.20	22.50

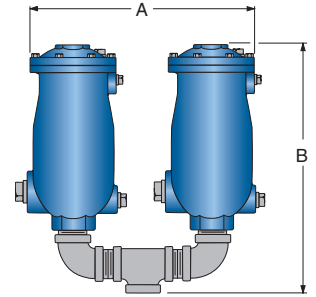

48A/301A - 49A/303A
Dual Body Wastewater
Combination Air Valves

WASTEWATER COMBINATION AIR VALVES (DUAL BODY)						
Inlet Size	Outlet Size	Model Number	CWP PSI	Orifice Size	Dimensions (Inches)	
					A	B
4" Flg	4" NPT	48A/304	150	3/16"	24.90	36.63
4" Flg	4" NPT	49A/304	150	7/16"	24.30	36.60
6" Flg	6" NPT	48A/306	150	3/16"	25.60	36.38
6" Flg	6" NPT	49A/306	150	7/16"	26.80	36.40
8" Flg	8" NPT	48A/308	150	3/16"	28.60	40.13
8" Flg	8" NPT	49A/308	150	7/16"	29.90	40.10

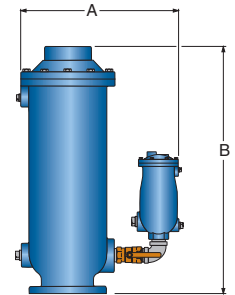

48A/304 - 49A/308
Dual Body Wastewater
Combination Air Valves



Single Body Wastewater Combination
Air Valve



Dual Body Combination Air Valve

Surge-Suppression Air Valves

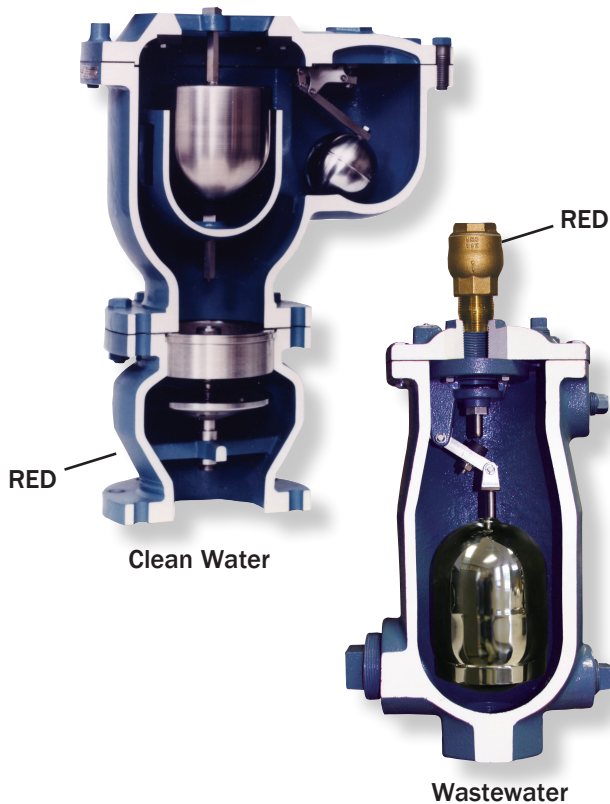

Operational Highlights:

- Provides full vacuum protection for the pipeline
- Provides slow closure suppressing surge in the pipeline
- Minimizes water blow-by during Air Valve closure
- Allows the use of smaller valve size by utilizing a maximum sizing differential pressure of 5 psig
- Releases entrained air while pipeline is operating to maintain pumping efficiency
- Includes Regulated Exhaust Device (RED)
- Fully complies with AWWA C512 and NSF 61

Surge-Suppression Air Valve Features:

- Restrictor disc provides regulated exhaust to limit secondary surges during column separation
- Ability to adjust air exhaust for greater surge suppression
- Provides full vacuum flow port

Optional Accessories:

- Outlet hood with screen (prevents debris from entering valves)
- Ball and butterfly isolation valves (allows valve maintenance)
- Inflow Preventer on outlet (stops flood water and resulting contamination from entering pipeline)
- Backwash kit (for severe wastewater applications)

MATERIALS OF CONSTRUCTION		
COMPONENT	STANDARD	OPTIONAL
Body	Cast Iron ASTM A126 Class B	Ductile Iron ASTM A536 Grade 65-45-12
Trim	Type 316 Stainless Steel (Air Valve) Lead Free Bronze ASTM B584 C87600 (RED)	Stainless Steel ASTM A351 Grade CF8M (RED)
Coating	Universal Acrylic Primer (external)	Non-Stick Fusion Bonded Epoxy (internal & external)

VENTING CAPACITY OF SURGE-SUPPRESSION AIR VALVE ORIFICES

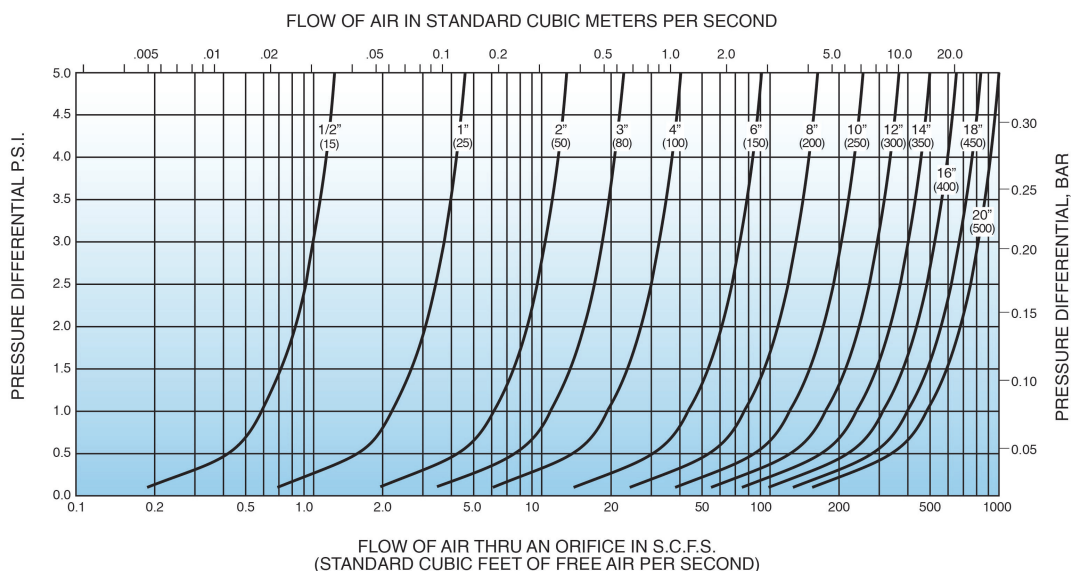

Surge-Suppression Air Valves

WATER SURGE-SUPPRESSION AIR VALVES (SINGLE BODY)						
Inlet Size	Outlet Size	Model Number*	CWP PSI	Orifice Size	Dimensions (Inches)	
					A	B
1" NPT	1" NPT	201CSS.1	250	5/64"	11.40	13.60
2" NPT	2" NPT	202CSS.1	250	3/32"	14.00	17.30
3" 125lb Flg	3" NPT	203CSSA.1	150	3/32"	16.00	22.75
3" 250lb Flg	3" NPT	253CSSA.1	300	3/32"	16.00	22.75
4" 125lb Flg	4" NPT	204CSSA.1	150	3/32"	18.50	27.00
4" 250lb Flg	4" NPT	254CSSA.1	300	3/32"	18.50	27.00
6" 125lb Flg	6" NPT	206CSSA.1	150	3/8"	21.00	30.00
6" 250lb Flg	6" NPT	256CSSA.1	300	7/32"	21.00	30.00
8" 125lb Flg	8" NPT	208CSSA.1	150	3/8"	25.00	36.00
8" 250lb Flg	8" NPT	258CSSA.1	300	7/32"	25.00	36.00

*NSF 61 & 372 Certified

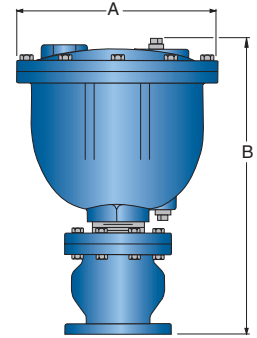

201CSS.1 - 258CSSA.1
Surge-Suppression Single Body
Air Valves

WATER SURGE-SUPPRESSION AIR VALVES (DUAL BODY)						
Inlet Size	Outlet** Size	Model Number*	CWP PSI	Orifice Size	Dimensions (Inches)	
					A	B
4" 125lb Flg	4" NPT	104SSA/38	150	3/16"	21.00	29.00
4" 250lb Flg	4" NPT	154SSA/38.5	300	5/32"	21.00	29.00
6" 125lb Flg	6" NPT	106SSA/38	150	3/16"	24.00	33.00
6" 250lb Flg	6" NPT	156SSA/38.5	300	5/32"	24.00	33.00
8" 125lb Flg	8" NPT	108SSA/38	150	3/16"	27.00	39.00
8" 250lb Flg	8" NPT	158SSA/38.5	300	5/32"	27.00	39.00
10" 125lb Flg	10" Flg	110FSSA/45	150	23/64"	32.10	46.20
10" 250lb Flg	10" Flg	160FSSA/45.5	300	7/32"	32.10	46.20
12" 125lb Flg	12" Flg	112FSSA/45	150	23/64"	36.10	48.20
12" 250lb Flg	12" Flg	162FSSA/45.5	300	7/32"	36.10	48.20

*NSF 61 & 372 Certified

**All outlet flanges are class 125 lb.

Note: For sizes 14" - 20" Consult Factory

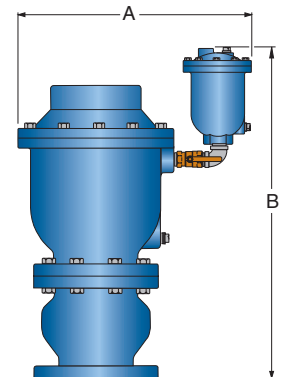

104SSA/38 - 162FSSA/45.5
Surge-Suppression Dual Body
Air Valves

WASTEWATER SURGE-SUPPRESSION AIR VALVES (SINGLE BODY)						
Inlet Size	Outlet Size	Model Number	CWP PSI	Orifice Size	Dimensions (Inches)	
					A	B
2" NPT	1" NPT	801SS	150	1/8"	7.00	18.00
2" NPT	2" NPT	802SS	150	9/64"	9.50	22.40
3" NPT	3" NPT	803SSA	150	11/64"	11.00	27.20
4" NPT	4" NPT	804SSA	150	11/64"	11.00	33.20

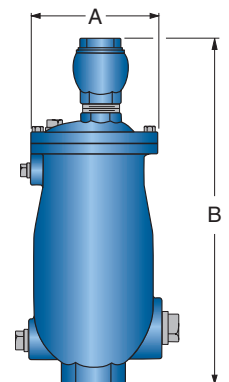

801SS - 804SSA
Surge-Suppression Single Body
Wastewater Air Valves

Air/Vacuum Valves for Vertical Pumps

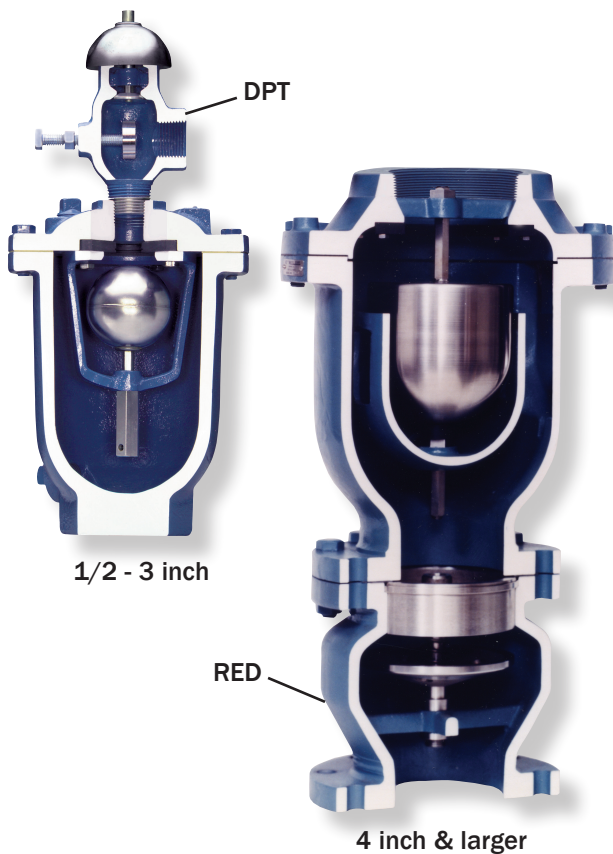

Operational Highlights:

- Regulates the exhaust of air on pump start-up
- Admits air to protect pump and mechanical seals
- Protects against air-related surges on pump start-up
- Fully complies with AWWA C512

Product Features:

- Unconditionally guaranteed 316 stainless steel floats
- Inlets and outlets are equal to full nominal pipe area
- 1/2" - 3" equipped with Dual Port Throttling Device
- 4" and larger equipped with Regulated-Exhaust Device mounted on the inlet

Dual Port Throttling Device (DPT):

- Adjustable discharge outlet provides regulated air exhaust
- Allows air to enter the system on pump shut down through an unrestricted independent vacuum port

Regulated-Exhaust Device (RED):

- Restrictor disc provides regulated exhaust to limit pump column surges
- Ability to adjust air exhaust for greater surge suppression
- Provides full vacuum flow port

MATERIALS OF CONSTRUCTION		
COMPONENT	STANDARD	OPTIONAL
Body and Cover	Cast Iron ASTM A126 Class B Class 125 and 250	Ductile Iron ASTM A536 Grade 65-45-12 Stainless Steel ASTM A351 Grade CF8M
Trim	Type 316 Stainless Steel (Air Valve) Lead Free Bronze ASTM B584 C87600 (RED)	_____
Coating	Universal Acrylic Primer (external)	Non-Stick Fusion Bonded Epoxy (internal & external)

AIR/VACUUM VALVE FOR VERTICAL PUMP SERVICE SIZING			
Valve Size	No Head Pump Capacity, GPM	Model Number	
		150 PSI Model	300 PSI Model
1/2"	0 - 350	100ST	
1"	351 - 1,350	101ST	
2"	1,351 - 4,000	102ST	
3"	4,001 - 7,000	103ST	
4"	7,001 - 11,000	104SSA.1	154SSA.1
6"	11,001 - 24,000	106SSA.1	156SSA.1
8"	24,001 - 50,000	108SSA.1	158SSA.1
10"	50,001 - 70,000	110FSSA.1	160FSSA.1
12"	70,001 - 110,000	112FSSA.1	162FSSA.1

Air/Vacuum Valves for Vertical Pumps

AIR/VACUUM VALVE FOR VERTICAL PUMPS WITH DUAL PORT THROTTLING DEVICE					
Inlet Size	Outlet Size	Model Number	CWP PSI	Dimensions (Inches)	
				A	B
1/2" NPT	1/2" NPT	100ST	300	6.13	11.75
1" NPT	1" NPT	101ST*	300	7.00	14.75
2" NPT	2" NPT	102ST*	300	9.50	20.13
3" NPT	3" NPT	103ST*	300	9.50	22.13

*UL Listed for fire pump service

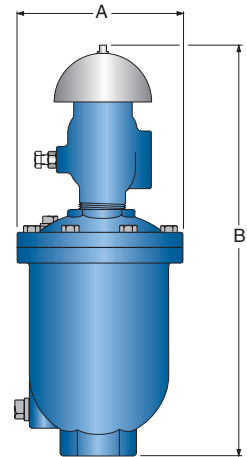

100ST - 103ST
Air Valves with
Dual Port Throttling Device

AIR/VACUUM VALVE FOR VERTICAL PUMPS WITH REGULATED-EXHAUST DEVICE					
Inlet Size	Outlet Size	Model Number	CWP PSI	Dimensions (Inches)	
				A	B
4" 125lb Flg	4" NPT	104SSA.1	150	11.50	23.63
4" 250lb Flg	4" NPT	154SSA.1	300	11.50	23.63
6" 125lb Flg	6" NPT	106SSA.1	150	14.00	28.50
6" 250lb Flg	6" NPT	156SSA.1	300	14.00	28.50
8" 125lb Flg	8" NPT	108SSA.1	150	17.25	34.63
8" 250lb Flg	8" NPT	158SSA.1	300	17.25	34.63
10" 125lb Flg	10" 125lb Flg	110FSSA.1	150	20.30	40.10
10" 250lb Flg	10" 125lb Flg	160FSSA.1	300	20.30	40.10
12" 125lb Flg	12" 125lb Flg	112FSSA.1	150	24.00	45.10
12" 250lb Flg	12" 125lb Flg	162FSSA.1	300	24.00	45.10

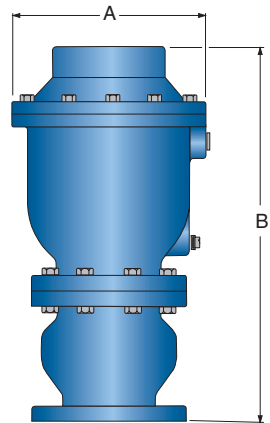

104SSA.1 - 162FSSA.1
Air Valves with
Regulated-Exhaust Device



Air/Vacuum Valve with Dual Port Throttling Device



Air/Vacuum Valve with Dual Port Throttling Device for Vertical Turbine Pumps

Vacuum Breaker Valves

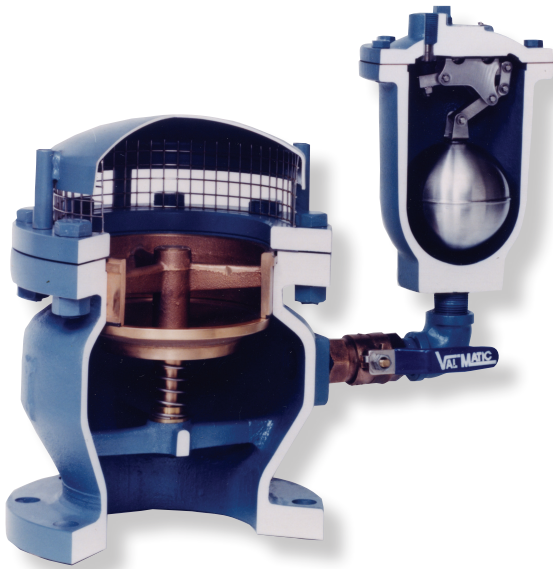

Vacuum Breaker with Optional Hood and Air Release Valve

Operational Highlights:

- Provides vacuum protection for pipelines and tanks
- Cushions surges related to column separation
- Opens in response to a 0.25 psi vacuum

Product Features:

- Resilient seals provide drop tight seating
- Full flow areas provide maximum vacuum protection

Optional Accessories:

- Hood with screen (prevents debris from entering valves)
- Air Release Valve (slowly releases air to prevent violent rejoining of water columns)
- Inflow Preventer on outlet (stops flood water and resulting contamination from entering pipeline)

MATERIALS OF CONSTRUCTION		
COMPONENT	STANDARD	OPTIONAL
Body and Cover	Cast Iron ASTM A126 Class B Class 125 and 250	Ductile Iron ASTM A536 Grade 65-45-12
Trim	Lead Free Bronze, ASTM B584, C87600	Stainless Steel ASTM A351 Grade CF8M
Coating	Universal Acrylic Primer (external)	Non-Stick Fusion Bonded Epoxy (internal & external)

VENTING CAPACITY OF VACUUM BREAKER ORIFICES

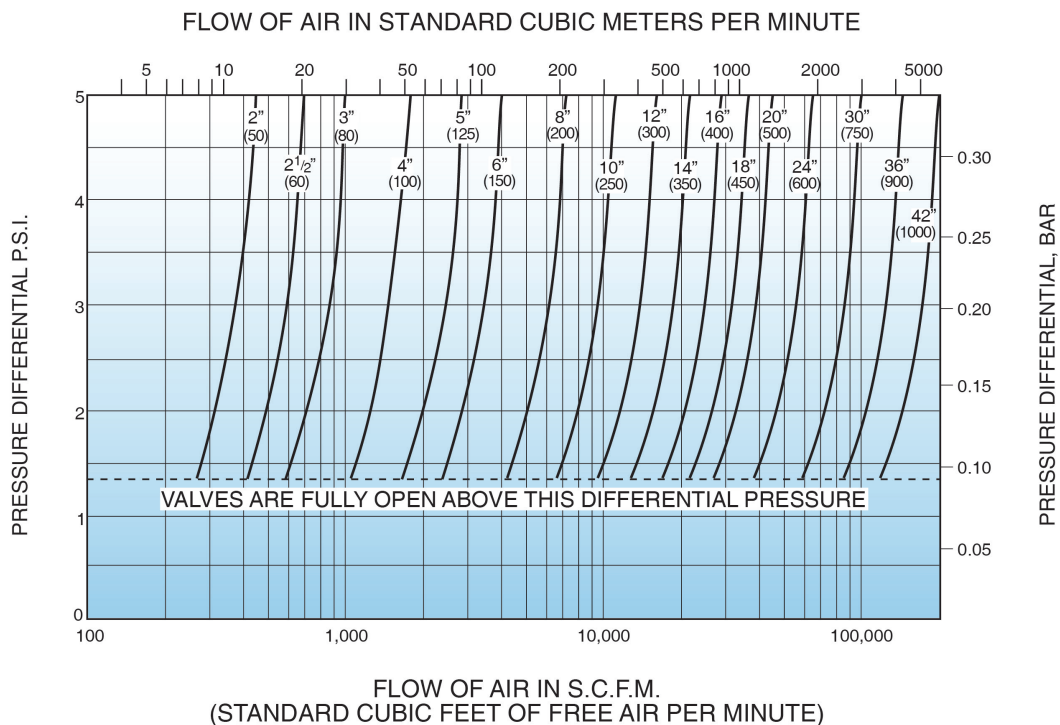

Vacuum Breaker Valves

THREADED VACUUM BREAKER AIR VALVE

Inlet	Outlet	Model Number*	CWP	Dimensions (Inches)	
				A	B
1/2" NPT	1/2" NPT	100VB	300	6.13	7.00
1" NPT	1" NPT	101VB	300	7.00	9.50
2" NPT	2" NPT	102VB	300	9.50	12.00
3" NPT	3" NPT	103VB	300	9.50	12.50

*NSF 61 & 372 Certified

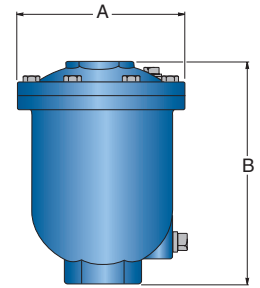

100VB-103VB
Vacuum Breaker Valves

FLANGED VACUUM BREAKER AIR VALVE

Inlet Size*	Model Number*		Model Number*		Dimensions (Inches)	
	125lb Class (CWP)		250lb Class (CWP)		A	B
2	1802AVB.1	200	1852AVB.1	400	7.00/7.50	5.50
2.5	1825AVB.1	200	1875AVB.1	400	7.00/7.50	5.50
3	1803AVB.1	200	1853AVB.1	400	7.50/8.25	6.00
4	1804AVB.1	200	1854AVB.1	400	9.00/10.00	7.25
5	1805AVB.1	200	1855AVB.1	400	10.00/11.00	8.50
6	1806AVB.1	200	1856AVB.1	400	11.00/12.50	9.75
8	1808AVB.1	200	1858AVB.1	400	13.50/15.00	12.50
10	1810AVB.1	200	1860AVB.1	400	16.00/17.50	15.50
12	1812AVB.1	200	1862AVB.1	400	19.00/20.50	14.30

*NSF 61 & 372 Certified

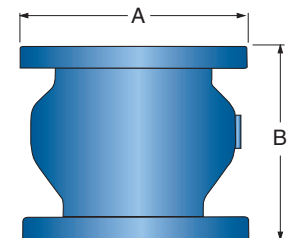

1802AVB.1-1862AVB.1
Vacuum Breaker Valves

FLANGED VACUUM BREAKER WITH AIR RELEASE VALVE

Inlet Size*	Model Number*		Model Number*		Dimensions (Inches)	
	125lb Class (CWP)		250lb Class (CWP)		A	B
3	1803AVB/38	150	1853VB/38.5	300	11.00	6.00
4	1804AVB/38	150	1854VB/38.5	300	11.50	7.25
5	1805AVB/38	150	1855VB/38.5	300	12.60	8.50
6	1806AVB/38	150	1856VB/38.5	300	13.30	9.75
8	1808AVB/38	150	1858VB/38.5	300	14.70	12.50
10	1810AVB/38	150	1860VB/38.5	300	16.30	15.50
12	1812AVB/38	150	1862VB/38.5	300	18.00	14.30

*NSF 61 & 372 Certified

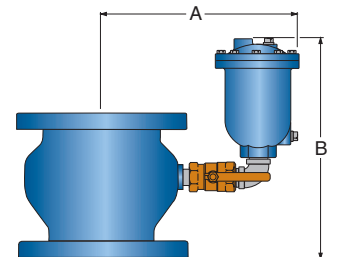

1803AVB/38 - 1862AVB/38.5
Vacuum Breaker Valves

FLANGED VACUUM BREAKER WITH AIR RELEASE VALVE FOR WASTEWATER SERVICE

Inlet Size*	Model Number	Model Number with Air Release Valve		Dimensions (Inches)			
		125lb Class (CWP)		A	B	C	D
3	1803VBS	1803VBS/48A	200	27.10	26.10	7.50	9.80
4	1804VBS	1804VBS/48A	200	20.10	21.80	9.00	10.50
6	1806VBS	1806VBS/48A	200	22.90	23.60	11.00	13.80
8	1808VBS	1808VBS/48A	200	25.55	25.20	13.50	17.40
10	1810VBS	1810VBS/48A	200	28.30	27.00	16.00	20.40
12	1812VBS	1812VBS/48A	200	31.50	25.30	19.00	20.80

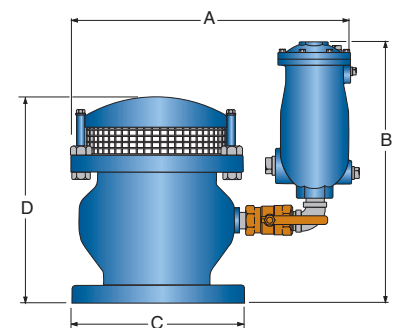

1803VBS - 1812VBS/48A
Vacuum Breaker Valves

*For sizes 14" - 42" consult factory

Vacuum Priming Valves



Operational Highlights:

- Allows the extraction of air from the pump housing and suction piping
- Float rises and closes the priming valve to prevent fluid from flowing into the vacuum priming system
- Continues to release air while the pump is running

Product Features:

- Specifically designed to prevent fluid leakage
- Flow sensitive float
- Stainless steel 316 internal trim and float

Optional Accessories:

- Water Level Control Switch (Mercury-Free)

MATERIALS OF CONSTRUCTION		
COMPONENT	STANDARD	OPTIONAL
Body and Cover	Cast Iron ASTM A126, Class B	Ductile Iron ASTM A536 Grade 65-45-12 Stainless Steel ASTM A351 Grade CF8M
Trim	Stainless Steel, Type 316	—
Coating	Universal Acrylic Primer (external)	Non-Stick Fusion Bonded Epoxy (internal & external)

VACUUM PRIMING VALVES						
Inlet Size	Outlet Size	Model No.	CWP PSI	Orifice Size	Dimensions (Inches)	
					A	B
2" NPT	1/2" NPT	38P	150	3/16"	7.00	15.31
2" NPT	1/2" NPT	38P.2	75	5/16"	7.00	15.31
2" NPT	1" NPT	45P	150	23/64"	9.50	17.56
2" NPT	1" NPT	45P.3	75	1/2"	9.50	17.56

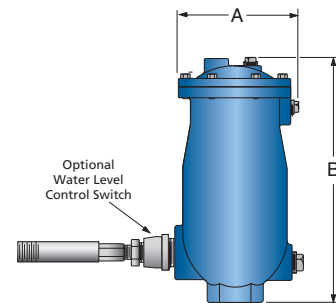

38P - 45P.3

Vacuum Priming Valve with Optional Water Level Control Switch

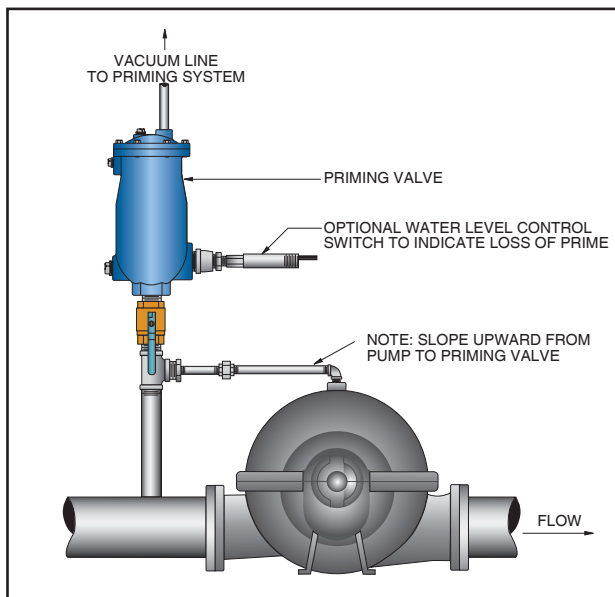

Recommended Piping Arrangement

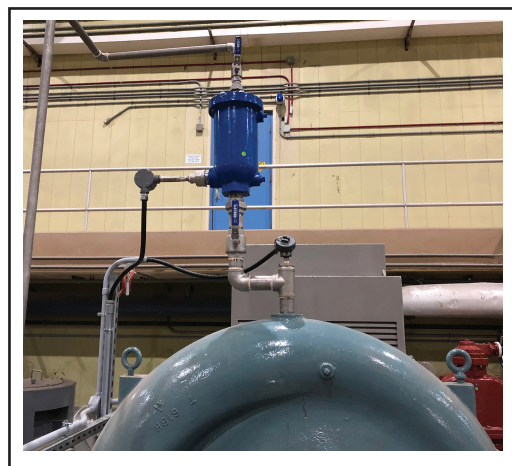

Vacuum Priming Valve

Air Valve Sizing Software

The Val-Matic Air Valve Sizing program is an easy to use, indispensable web based program that allows engineers to more effectively and efficiently design their water and wastewater piping systems.

- 1 The pipeline profile data is entered into the program which evaluates system data and develops sizing criteria such as slope for each pipeline segment and flow rate due to slope.
- 2 It will recommend valve locations, sizes and models and print a valve schedule.
- 3 It will also prepare a pipeline profile for the user. Finally, the program will save your data for future reference.

1 Pipeline Air Valve Sizing

Name: Sample Project

Owner: Project Owner

Engineer: Valmatic

Max Flow Rate: 30000 GPM

Fill Rate: 12000 GPM

Valve Selection Criteria: Surge-Suppression Dual Body CAV

Type of Media: Water - ANSI/NSF 61 Certified

Pipe Material: Steel or Stainless

Pipe Inner Diameter: 47 in

Pipe Line Profiles: Feet

#	Station	Elevation
1	0	0
2	3200	10
3	8400	10
4	9200	20
5	11200	16

2

Station (ft)	Elevation (ft)	Description	Value Recommendations (Size/Model)	Flow Rate CFS	Slope
0	0	Beginning of Pipeline	No valve necessary	0.000	0.000
1600	5	Long Ascent	6 IN #106SS Air/Vac Reg-Ex	38.680	0.003
3200	10	High Point	8 IN #108SS/38 Surge-Suppression	77.360	0.003
4933	10	Horizontal Run	2 IN #38.2 Air Release	0.000	0.000
6666	10	Horizontal Run	4 IN #104SS/22.9 Surge-Suppression	0.000	0.000
8400	10	Low Point	No valve necessary	0.000	0.000
9200	20	High Point	10 IN #110FSS/45 Surge-Suppression	134.662	0.013

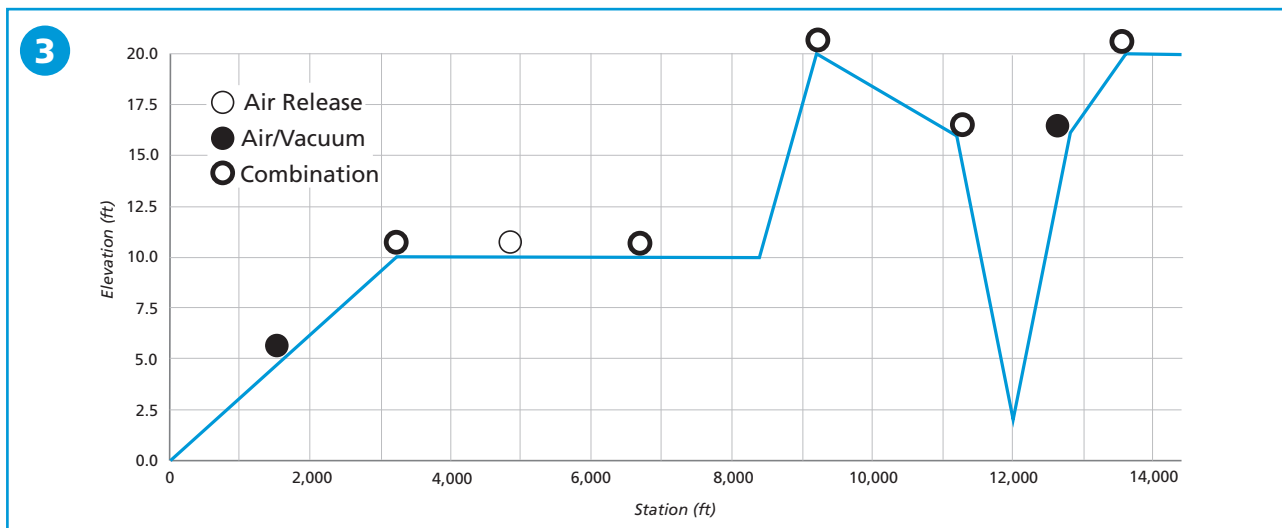

FloodSafe® Inflow Preventer

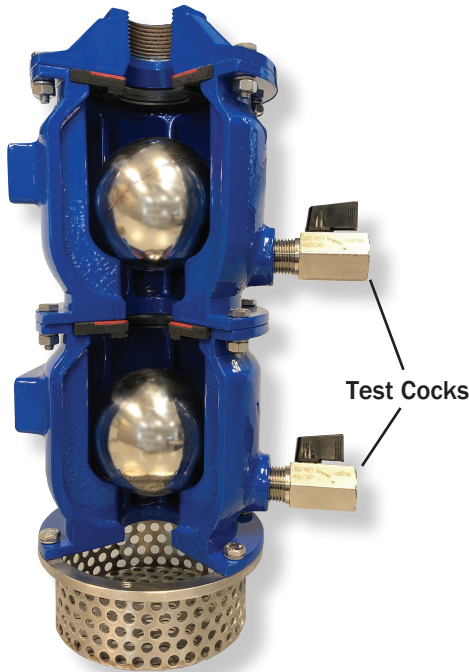

Operational Highlights:

- Piped to an outlet for an air valve
- Protects potable water systems from flooding and malicious contamination
- Field testing capability
- Low pressure shut off
- Dual float checks for added protection
- Fully complies with AWWA C514 and the Ten State Standards for Water Works

Product Features:

- Cross contamination control
- Adaptable to existing air valve installations
- Dual chamber design with upper chamber as a back up
- Dual float checks designed to assure rapid closure upon the entry of fluid into the chamber.
- Patented resilient seats are specially designed and formulated to assure drop tight closure at low pressures.
- Test ports allow for independent testing of both chambers
- Basket screen prevents debris from entering
- Port sized cover to allow for full venting capacity of air valve or vent

Optional Accessories:

- Field test kit
- Wall bracket

MATERIALS OF CONSTRUCTION	
COMPONENT	STANDARD
Upper & Lower Chambers, Cover	Ductile Iron, ASTM A536 Grade 65-45-12
Upper & Lower Check Floats	Stainless Steel, Type 316
Check Seat	Resilient
Basket Screen	Stainless Steel, Type 304
Coatings	Fusion Bonded Epoxy (internal/External)



FloodSafe® Inflow Preventer



FloodSafe® Inflow Preventer with a Combination Air Valve

FloodSafe® Inflow Preventer

FLOODSAFE INFLOW PREVENTER					
Valve Size	Model Number	Connection Size	PSI	Dimensions (Inches)	
				A	B
1"*	1301	1" NPT	25	6.38	13.13
2"*	1302	2" NPT	25	7.25	16.63
3"	1303	3" NPT	25	9.00	19.88
4"	1304	4" NPT	25	9.25	23.00
6"	1306	6" FLG	25	12.75	30.75
8"	1308	8" FLG	25	14.62	36.88
12"	1312	12" FLG	25	20.25	53.50
16"	1316	16" FLG	25	24.88	68.13

* ASSE 1063 Certified

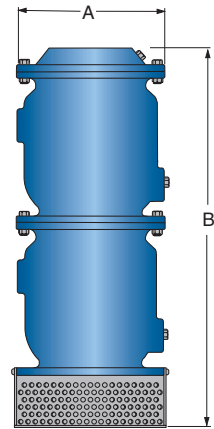

1301-1316
FloodSafe®

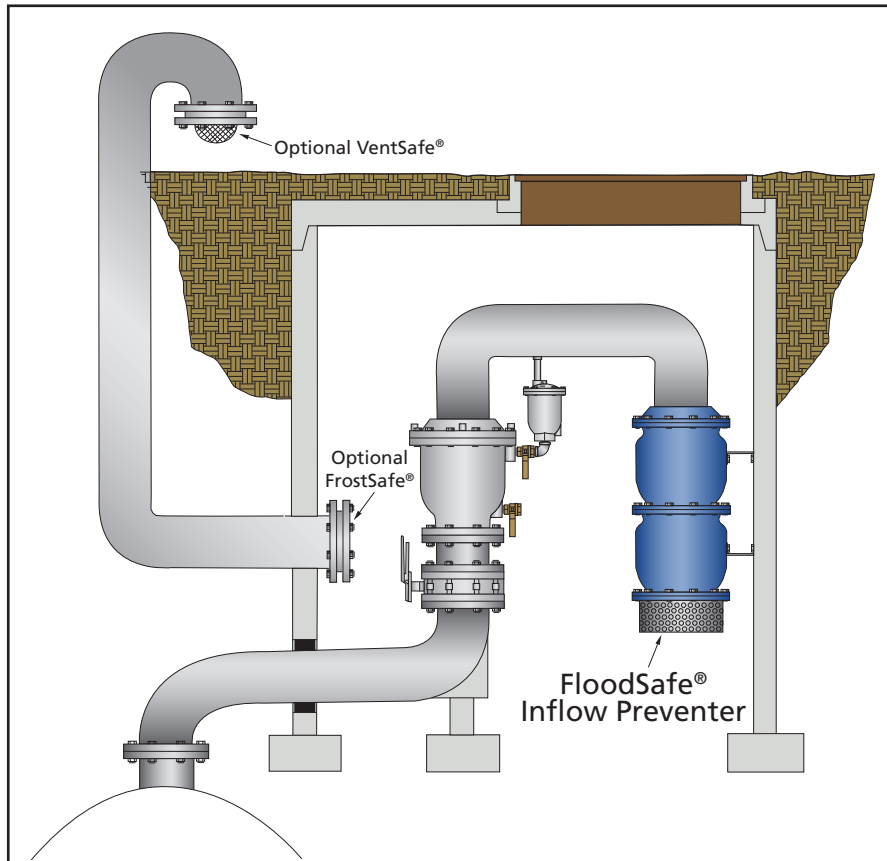

Typical Vault Installation with FloodSafe® Inflow Preventer

The FloodSafe® is piped to the outlet of an air release valve, air/vacuum valve, or combination air valve of vent. As water in a flooded area or vault rises, the float check in the lower chamber rises preventing contaminated water from continuing past the chamber. The redundant upper chamber provides a backup in much the same way a backflow preventer works. If contaminated water continues past the seat of the lower chamber the float check in the upper chamber rises preventing fluid from reaching the air valve outlet. Under normal operating conditions the FloodSafe® provides full venting capacity of the air valve or vent.

FrostSafe® Two-Way Damper



Operational Highlights:

- Wafer style bidirectional hingeless damper
- Installed in vent piping
- Protects air valve from freezing
- Minimizes the flow of cold air into vaults through vent pipes
- Provides 100% flow area
- 100% corrosion resistant construction
- Allows Air Valves to function at full rated capacity

Product Features:

- High density polyethylene body
- Damper seal
- Adaptable to existing vent pipes
- Wafer design minimizes space requirements

MATERIALS OF CONSTRUCTION	
COMPONENT	STANDARD
Body	High Density Polyethylene (HDPE)
Rubber Membrane	Nylon Reinforced High Grade Neoprene
Damper Seal	PETG
Body Bolt	Stainless Steel, Type 316

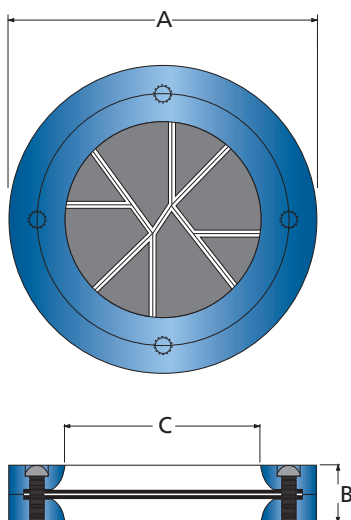

FROSTS SAFE® TWO-WAY DAMPER				
Size	Model Number	Dimensions (Inches)		
		A	B	C
4	1504	6.75	0.75	4.00
6	1506	8.88	1.00	6.00
8	1508	10.88	1.25	8.00
12	1512	16.00	2.00	12.00



FrostSafe® Two-Way Damper

VentSafe® Security Cage

Operational Highlights:

- Installed in vault or reservoir vent pipes
- Helps prevent bugs, birds and small animals from nesting in vent pipes
- Helps prevent malicious introduction of liquids and other matter
- Provides 100% flow area
- 100% corrosion resistant construction

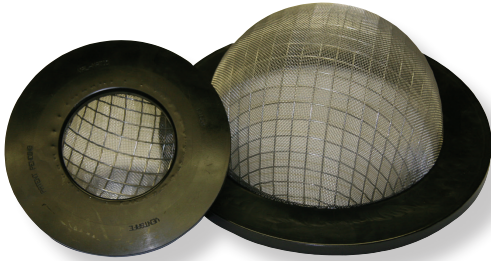

Product Features:

- Flow area equal to 100% of pipe area
- Adapts to existing vent pipes
- Wafer design minimizes space requirements
- 24 mesh screen complies with USEPA and Ten State Standard requirements for tank vent lines

MATERIALS OF CONSTRUCTION	
COMPONENT	STANDARD
Body	45 Shore D PVC
Screen, 24 Mesh	Stainless Steel, Type 304
Cage, 2 Mesh	Stainless Steel, Type 304

VENTSAFE® SECURITY CAGE					
Size	Model Number	Dimensions (Inches)			
		A	B	C	D
4	1604	6.75	0.375	3.76	2.37
6	1606	8.63	0.375	5.75	3.37
8	1608	10.88	0.375	7.77	4.37
12	1612	16.00	0.375	11.75	6.00

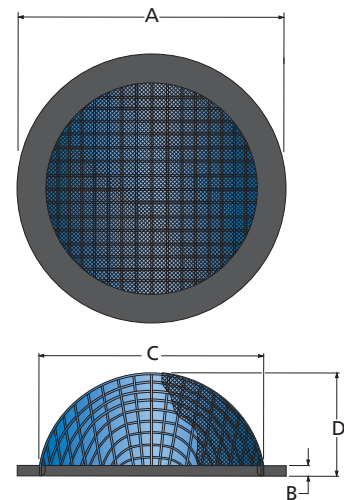

VentSafe® Security Cage



VentSafe® Security Cage
Installed on Vent Pipe



Val-Matic's quality of design and meticulous workmanship has set the standards by which all others are measured. Quality design features such as the AWWA **Ener•G® Ball Valve** with its energy efficient design, fusion bonded epoxy and adjustable resilient seating....**Cam-Centric® Plug Valves** have more requested features than any other eccentric plug valve....**American-BFV® Butterfly Valves** include a field replaceable seat without the need for special tools....**Tilted Disc® Check Valves** with high strength and wear resistant aluminum bronze trim as standard....**Silent Check Valves** featuring combined resilient/metal-to-metal seating and are **NSF/ANSI 61 & 372 Certified**....**Sure Seal Foot Valves** provided with a heavy duty stainless steel screened inlet....**Swing-Flex® and Surgebuster® Check Valves** designed with an unrestricted full flow area....**Swing Check Valves** with field

adjustable closure versatility....**Dual Disc® Check Valves** utilizing stabilized components to provide extended life....**Air Release, Air/Vacuum and Combination Air Valves** provided standard with Type 316 stainless steel trim....**VaultSafe®** family of products includes the **FloodSafe® Inflow Preventer, FrostSafe®** two-way damper and the **VentSafe®** vent pipe security cage. The **QuadroSphere® Trunnion Ball Valve** features a unique ball design with recessed surfaces creating additional flow paths to provide a self-cleaning action and reduced wear and torque.

Val-Matic is totally committed to providing the highest quality valves and outstanding service to our customers. Complete customer satisfaction is our goal. **Make the change to quality, specify Val-Matic!**



Air Valves



VaultSafe®



36 Hudson Rd
Sudbury MA 01776



800-225-4616
www.tisales.com

Val-Matic Valve and Manufacturing Corp.
905 Riverside Drive, Elmhurst, IL 60126
Phone: 630-941-7600 • Fax: 630-941-8042
www.valmatic.com • valves@valmatic.com

Copyright © 2020 Val-Matic Valve & Mfg. Corp.
ISO 9001:2015 certified company