



FLOMOTION ALH

HOSE PUMPS

INSTRUCTION MANUAL

CONTENTS

1/ HOW TO USE THIS MAINTENANCE MANUAL	3
2/ SECURITY AND GUARANTEES	3
2.1 - Use of the pump	3
2.2 - Responsibility	3
2.3 - Training and instructions	3
2.4 - Conditions of guarantee	3
3/ DESCRIPTION	4
3.1 - Product identification	4
3.2 - Operation principle	4
3.3 - Pump construction	
3.3.1 - Pumps ALH05 to ALH20	
3.3.2 - Pumps ALH25 to ALH65	
3.3.3 - Pumps ALH80 to ALH125	5
3.4 - Pump hose	8
3.5 - Pump gearbox	8
3.6 - Electrical Motor	8
3.7 - Available Options	8
4/ INSTALLATION	9
4.1 - Unpacking and control	9
4.2 - Conditions of installation	9
4.3 - Setup	9
4.4 - Piping	9
4.5 - Pump lifting	10
5/ PUMP START-UP	10
5.1 - Preparations	10
5.2 - Pump start-up	10
6/ MAINTENANCE	10
6.1 - Emptying and filling of the lubricant	10
6.2 - Hose cleaning	12
6.3 - Hose replacement	12
6.3.1 - Removing the hose	
6.3.2 - Cleaning of the pump casing	
6.3.3 - Reassembly of the hose	
6.4.1 - REPLACEMENT OF PUMP SHOES (EXEPT ALH05, 10, ALH15, ALH20)	
Replacement of pump shoes (except ALH05, 10, ALH15, ALH20)	
6.4.2 - REPLACEMENT OF THE SEAL RING REP27 AND THE SHAFT SEAL REP26	
Replacement of the seal ring REP27 and the shaft seal RP26	
6.4 - Replacement of spare parts	16
6.5 - Shoe shimming	20
6.6 - ALHS series complementary information	21
6.7 - Maintenance and periodical controls	22
6.7.1 - Set up	
6.7.2 - Pump starting	
6.7.3 - Bearing case dismantling and lip seal pos26 replacement	
6.7.4 - Maintenance and periodical controls	
7/ STORAGE	22
7.1 - Pump storage	22
7.2 - Hose storage	22
8/ TROUBLESHOOTING	23
9/ CHARACTERISTICS AND TECHNICAL SPECIFICATIONS	25
9.1 - Performances curves	25
9.2 - Overall dimensions	28
9.3 - Nomenclature	32
9.4 - ALH Spare parts list	40
9.5 - ALHS Bearing case parts list	41
9.6 - Hose rupture and vacuum system parts list	41
9.7 - Lubrication table	42
9.8 - Shoe shimming table	42
9.9 - Generated noise and temperature	43
9.10 - Expansible hub assembly and disassembly : generalities	44
9.11 - Torques	45
9.12 - Weights	46
10/ COMPLEMENTARY INSTRUCTIONS FOR ATEX CERTIFIED MATERIAL	47
11 / SECURITY FORM	55
12 / STATEMENT OF CE COMPLIANCE	56

1/ HOW TO USE THIS MAINTENANCE MANUAL

This manual is specific to ALBIN PUMP ALH and ALHS series hose pumps. It allows the users to install, to start and to carry out maintenance on these pumps. All persons, fitters and users must read this maintenance manual in its entirety. The ALH series are provided with a gearmotor and the ALHS series are bare shaft pumps. All dimensions, spare parts, materials and characteristics are the same for the two series unless specified. Documents concerning the gearbox, the electrical motors as well as all other options (pulsation dampener, hose rupture detector etc) are provided in annex. Refer to in these documents to know the specific details of every apparatus.

Your local ALBIN distributor is at your disposal for the information that you would not find in this manual. For short reply, please indicate the following informations :

- Type of pump
- Pump serial number
- Reference of order

You can also visit our website albinpump.com for further information.

2/ SECURITY AND GARANTEES

2.1 - USE OF THE PUMP

The pump was defined for a specific application. Any other use which does not comply with envisaged use is not guaranteed. ALBIN PUMP cannot be held responsible for damage or possible wounds produced during the use of the pump. The pump was designed in accordance with EU norms and applicable directives. Use the pump only for applications represented above. If you want to change your application, first contact your Albin pump distributor.

2.2 - RESPONSIBILITY

ALBIN PUMP SAS will be under no circumstances responsible for damage or wounds caused by non respect of security directives and maintenance instructions contained in this manual, or by negligence during the installation, use, service or repair of ALBIN hose pumps. Moreover, additional directives of security can be necessary according to working conditions or according process. Contact your ALBIN PUMP distributor if you notice a potential danger during the use of the pump.

2.3 - TRAINING OF THE USER AND INSTRUCTIONS

Every person who installs, uses or performs any operations of maintenance on the pump must be qualified and must have previously read this technical manual. Any temporary personnel must be supervised by skilled users.

The order of execution of operations defined in this manual must be absolutely respected. Store this manual next to the pump so that it can be consulted at any time.

2.4 - CONDITIONS OF GUARANTEE

ALBIN PUMP S.A.S offers a guarantee of 2 years on the pump's parts. ALBIN PUMP S.A.S promises to repair or to replace for free all damaged parts except if their deterioration came from a poor use of the pump. This concerns all parts except for the hose, the clamps, the sleeves, seals, bushings and bearings as well as the pump shoes.

ALBIN PUMP SAS will not be able to accept a request of guarantee under no circumstances if the used parts are not of ALBIN PUMP origin. Any damaged parts covered by guarantee must be returned to the ALBIN PUMP factory or to the local ALBIN PUMP distributor. The returned parts must be accompanied with the duly filled and signed security form. A copy of this form is at the end of this manual. It must be appended in a visible way outside the packing. The potentially dangerous parts for health must be cleaned before returning them to the producer. It must be pointed out on the security form how parts were cleaned and those that have been decontaminated.

ALBIN PUMP SAS is under no circumstances urged to respect guarantees given in its name by a third, whatever it is, representatives of ALBIN PUMP SAS, subsidiaries and representatives including unless a specific agreement is written by a manager of ALBIN PUMP SAS.

3/ DESCRIPTION

3.1 - IDENTIFICATION OF THE PUMP

ALBIN PUMPS are identifiable by the pump plate located on the upper bracket. This one includes the type and serial number of the pump. This serial number leads to all information concerning building materials, nature of the hose, characteristics of the gearbox and characteristics of the motor. The gearbox as well as the motor include their own descriptive plate on which you can read the reduction ratio, power and electrical voltage etc.

3.2 - OPERATION PRINCIPLE

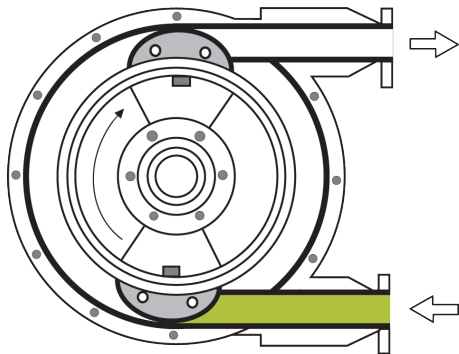

PHASE 1

The pump hose is compressed successively by two pressing shoes assembled on a rotating wheel. The first shoe, by pressing the walls of the hose, will create a vacuum and attract the pumped liquid into the hose.

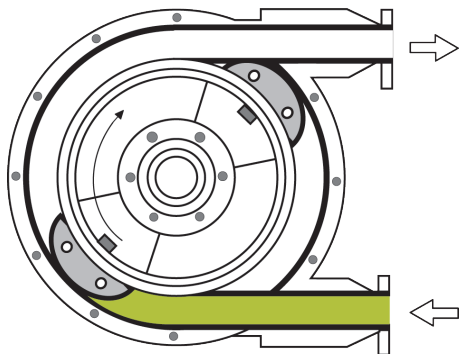

PHASE 2

The pumped liquid has now entered the hose. The second shoe will compress the hose and push the liquid towards the pump outlet.

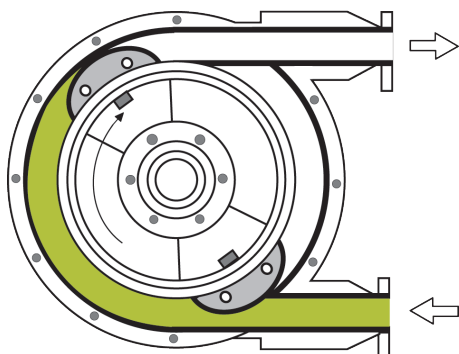

PHASE 3

As soon as, at the discharge side, the shoe is detached from the hose, the other shoe diametrically opposite is already in compression thus avoiding an internal product leakage. The product is then successively sucked and pushed due to the wheel rotation.

3.3 - PUMP CONSTRUCTION

3.3.1 - PUMPS ALH05 TO ALH20

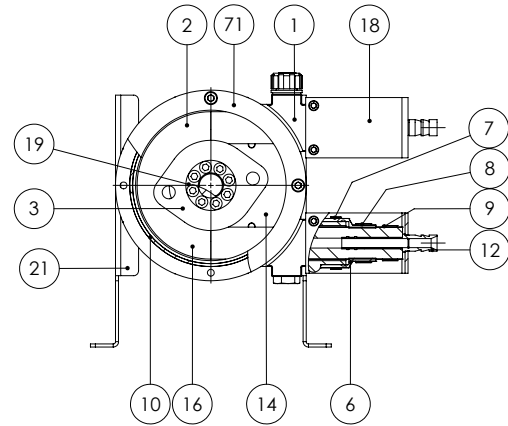
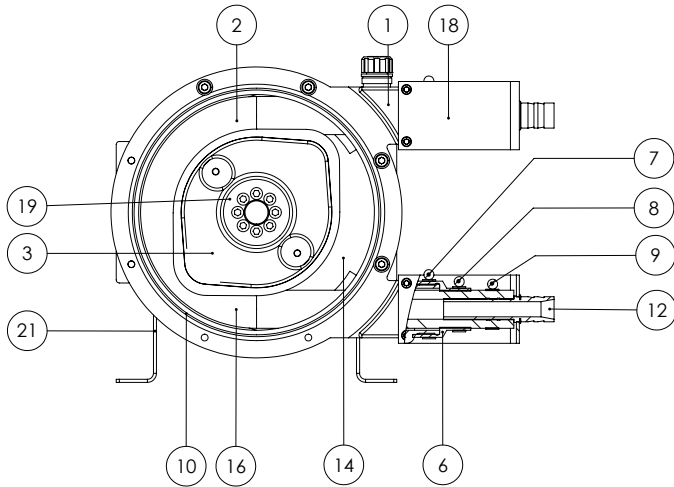

PUMP ALH15 - 20

PUMP ALH05 - 10

PART NO	DESIGNATION	ALH 05 - 10	ALH15-20
1	CASING	CAST IRON	CAST IRON
2	COVER	LEXAN	LEXAN
3	WHEEL	CAST IRON	CAST IRON
6	SLEEVE	EPDM	EPDM
7	CLAMP ON CASING	STAINLESS STEEL	STAINLESS STEEL
8	CLAMP SLEEVE / HOSE	BICHROMATED STEEL	BICHROMATED STEEL
9	CLAMP ON HOSE	BICHROMATED STEEL	BICHROMATED STEEL
10	SEAL COVER	NITRILE	NITRILE
12	INSERT	STAINLESS STEEL/PPH/PVDF	STAINLESS STEEL/PPH/PVDF
14	LUBRICANT	GLYCERIN BLEND	GLYCERIN BLEND
16	HOSE	NR/NBR/EPDM/NBR food/Viton/Hypalon	NR/NBR/EPDM/NBR food/Viton/Hypalon
18	BRACKET	ELECTROPLATED STEEL	ELECTROPLATED STEEL
19	HUB	STEEL	STEEL
21	FRAME	ELECTROPLATED STEEL	ELECTROPLATED STEEL
71	COVER FLANGE	ELECTROPLATED STEEL	WITHOUT FLANGE

3.3.2 - PUMPS ALH25 TO ALH65

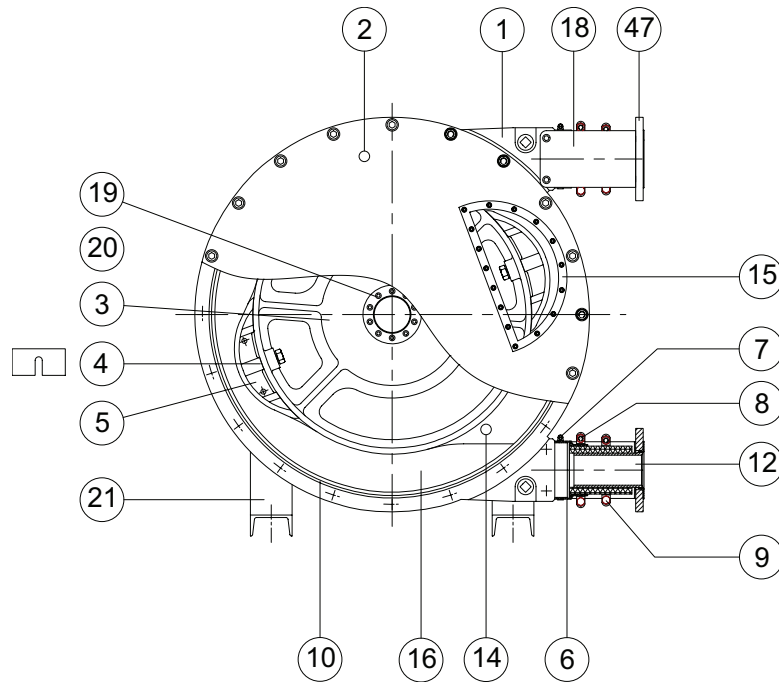

PART NO	DESIGNATION	ALH 25 - 32 - 40	ALHX 40 - 50 - 65
1	CASING	CAST IRON	CAST IRON
2	COVER	ELECTROPLATED STEEL	STEEL
3	WHEEL	CAST IRON	CAST IRON
4	SHIM	GALVANIZED STEEL	GALVANIZED STEEL
5	SHOE	ALUMINIUM	CAST IRON
6	SLEEVE	EPDM	EPDM
7	CLAMP ON CASING	STAINLESS STEEL	STAINLESS STEEL
8	CLAMP SLEEVE / HOSE	STAINLESS STEEL	STAINLESS STEEL
9	CLAMP ON HOSE	STAINLESS STEEL	BICHROMATE STEEL
10	SEAL COVER	NITRILE	NITRILE
12	INSERT	STAINLESS STEEL/PPH/PVDF	STAINLESS STEEL/PPH/PVDF
14	LUBRICANT	GLYCERIN BLEND	GLYCERIN BLEND
15	SIGHTGLASS SEAL	LEXAN	LEXAN
16	HOSE	NR/NBR/EPDM/NBR food/Viton/Hypalon	NR/NBR/EPDM/NBR food/Viton/Hypalon
18	BRACKET	ELECTROPLATED STEEL	ELECTROPLATED STEEL
19	HUB	STEEL	STEEL
21	FRAME	STEEL	STEEL
46	SIGHT GLASS SEAL	NITRILE	NITRILE
47	INLET/OUTLET FLANGE	STAINLESS STEEL	STAINLESS STEEL

3.3.3 - PUMPS ALHX80 TO ALH125

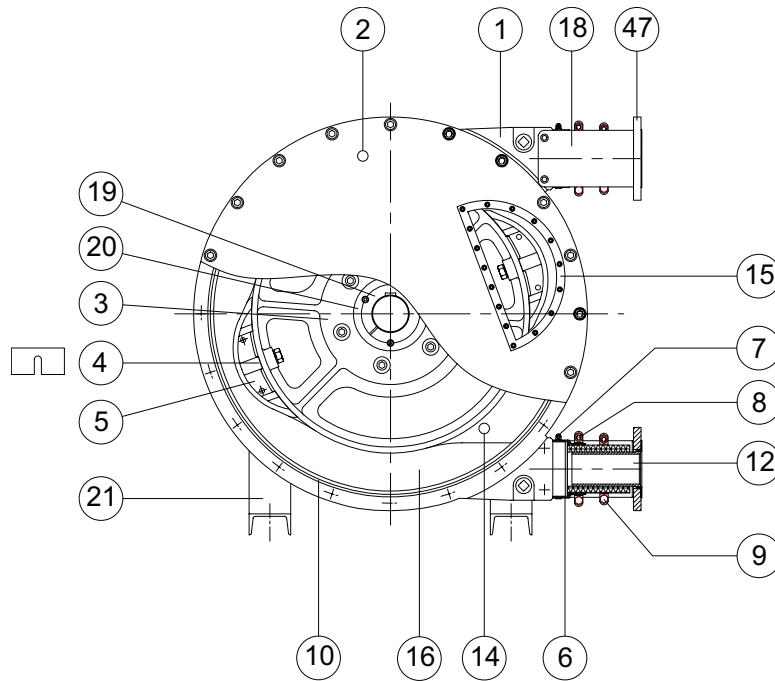

PART NO	DESIGNATION	ALHX 80 - ALH 80	ALH 100 - ALH 125
1	CASING	CAST IRON	CAST IRON
2	COVER	STEEL	STEEL
3	WHEEL	CAST IRON	CAST IRON
4	SHIM	GALVANIZED STEEL	GALVANIZED STEEL
5	SHOE	CAST IRON	CAST IRON
6	SLEEVE	EPDM	EPDM
7	CLAMP ON CASING	STAINLESS STEEL	STAINLESS STEEL
8	CLAMP SLEEVE / HOSE	STAINLESS STEEL	STAINLESS STEEL
9	CLAMP ON HOSE	BICHROMATE STEEL	BICHROMATE STEEL
10	SEAL COVER	NITRILE	NITRILE
12	INSERT	STAINLESS STEEL/PPH/PVDF	STAINLESS STEEL/PPH/PVDF
14	LUBRICANT	GLYCERIN BLEND	GLYCERIN BLEND
15	SIGHT GLASS	LEXAN	LEXAN
16	HOSE	NR/NBR/EPDM/NBR food/Viton/Hypalon	NR/NBR/EPDM/NBR food/Viton/Hypalon
18	BRACKET	ELECTROPLATED STEEL	ELECTROPLATED STEEL
19	HUB	STEEL	
20	BOLT ON PLATE	CAST IRON	
21	FRAME	STEEL	STEEL
46	SIGHT GLASS SEAL	NITRILE	NITRILE
47	INLET/OUTLET FLANGE	STAINLESS STEEL	STAINLESS STEEL

3.4 - HOSE

The ALBIN hoses are manufactured according to very strict specifications to acquire the best performances of the pump and to assure an optimum hose life. They are available in six materials : Natural Rubber (NR), perbunan (NBR), EPDM, NBR food, Hypalon, and viton. The material of the hose must be compatible with the pumped liquid. Consult an ALBIN PUMP distributor to define the best hose for your process or consult the chemical resistance table on our website albinpump.com.

HOSE DIMENSIONS (dimensions in mm)

PUMP	DISTANCE (L)
ALH05	400
ALH10	400
ALH15	500
ALH20	500
ALH25	800
ALH32	1000
ALH40	1000
ALHX40	1200
ALH50	1400
ALH65	1400
ALHX80	1600
ALH80	2000
ALH100	2800
ALH125	3000

PUMP	Ø INSIDE	THICKNESS	LENGTH
ALH05	5	13,5	570
ALH10	10	11	570
ALH15	15	11	830
ALH20	20	9	830
ALH25	25	14,5	1090
ALH32	32	15,5	1300
ALH40	38	13,5	1300
ALHX40	40	13,5	1500
ALH50	51	15	1820
ALH65	60	13,5	1850
ALHX65	65	17,5	2335
ALHX80	80	17,5	2400
ALH80	80	21,5	2910
ALH100	100	22	3410
ALH125	125	21,25	4000

3.5 - GEARBOX

Our standard gearboxes are coaxial gearboxes for pumps ALH05 to ALHX40 and planetary for pumps ALH50 to ALH100. ALH125 can be equipped with both. They have been sized according to the important radial loads of the pump. Consult the gearbox maintenance manual provided with the pump to know the quantity of lubricant requested as well as the periodicity of oil change.

3.6 - ELECTRICAL MOTORS

The standard motors provided on our pumps are squirrel-cage motors and have a 220/400 & 400/660V 50Hz tri-phase voltage.

If the pump has to work in a potentially explosive environment, please refer to the complementary information on ATEX compliances and contact your ALBIN PUMP distributor.

3.7 - AVAILABLE OPTIONS

ALBIN PUMP offers several options for their pumps :

- Hose rupture detector.
- Revolution-counter.
- Pulsation dampener.
- Air vacuum assistance (for highly viscous liquids).

Please contact your ALBIN PUMP distributor for any information about these different options.

4/ INSTALLATION

4.1 - UNPACKING AND CONTROL

During the reception of the pump, please follow the indications pointed out on the packing. Undertake a visual control to be sure that no damage happened during the transport. If this is the case, please contact your ALBIN PUMP distributor as soon as possible.

4.2 - CONDITIONS OF USE

ALH pumps can work in atmospheres where the temperature is situated between - 20°C and +45°C. Pumps are delivered painted with a 150µ polyurethane paint which allows them to resist to certain aggressive ambiences. They are designed for indoor and outdoor setups.

4.3 - SET UP

Before installing the pump, check the following points :

- The pump is delivered with a frame provided with four anchoring holes. It must be fixed on a solid base with a slope which does not exceed 5mm for 1m and must be firmly fastened to this one.
- Require enough space around the pump to carry out maintenance. If such was not possible, consider the moving of the pump to a space provided for this purpose.
- Make sure that the room is adequately ventilated to relieve the heat generated by the pump. Leave a space behind the motor ventilator hood so as not to obstruct air intake.

4.4 - PIPING

Suction line piping :

- The internal diameter of the piping must be superior to that of the pump hose (see §3.4.).
- It must be the shortest and most direct possible to avoid suction loss.
- Install a valve on the suction line especially if the pump is on load.
- Limit the presence of bends and make sure that they are as large as possible.
- Make sure that piping can support the service pressure of the pump.

Discharge line piping :

- The internal diameter of piping must be superior to that of the pump hose (see §3.4.).
- It must be the shortest and most direct possible to avoid discharge pressure loss.
- Limit the presence of bends and make sure that they are as large as possible.
- Provide a space for a pulsation dampener (see picture below).
- If there is a valve on the discharge line, install a pressure valve or a over pressure protection gauge to avoid any possible damage to the pump and to the installation.
- It is recommended to install a Dillatoflex® pipe to absorb vibrations created by the pump pulsations.

During the pump ground study, provide enough space for the hose change as well as the possible installation of a pulsation dampener.

Distance (L) is the required length for hose removal.

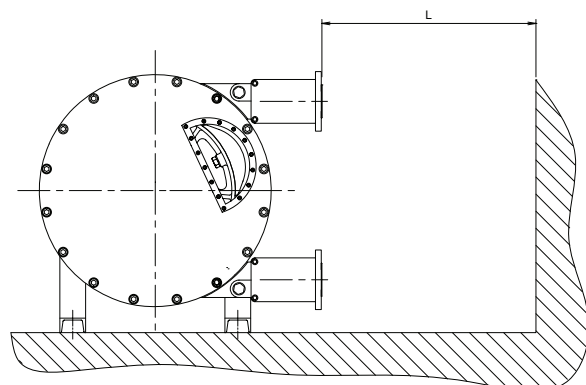

4.5 - LIFTING THE PUMP

Pumps are provided with two lift rings fitted on the upper part of the frame. While lifting the pump, respect the following points :

- Lift the complete hose pump using the lifting rings plus additional support on the gearbox and the motor using suitably rated straps or slings.
- Never exceed the upper limits of lift and control the motorized pump weights in the table below.
- The motorized pump, given its centre of gravity, will tend to overbalance on the pump head side. Make sure that the persons are at a security distance of the pump to avoid any risk of wound.
- Never raise the pump otherwise than by the pump's lifting rings.
- Never raise the pump by its orifices nor by its brackets.

PUMP	ALH05-10	ALH15	ALH20	ALH25	ALH32	ALH40	
WEIGHT KG	25	35	35	80	130	145	
PUMP	ALHX40	ALH50	ALH65	ALHX80	ALH80	ALH100	ALH125
WEIGHT KG	210	315	335	650	930	1250	1750

5/ PUMP START-UP

5.1 - PREPARATIONS

- a. Connect the electrical motor in accordance with the local rules and regulations. Perform this work by qualified personnel.
- b. Make sure that the lubricant level arrives at the level of the sight glass. Add lubricant if required by the breather or by the sight glass (see §6.1.).
- c. Make sure the shimming of the pump is according to the pump process (see §6.5 shoe shimming).
- d. Check the direction of rotation of the pump. It is recommended to install a rotation inverter on the motor for the hose change.

5.2 - START-UP

- a. Install piping at the inlet and outlet of the pump.
- b. Make sure that valves at the inlet and outlet are opened.
- c. Start the pump by checking its direction of rotation by the sight glass.

6/ MAINTENANCE

6.1 - EMPTYING AND FILLING OF THE LUBRICANT

Refer to §6.6 to know the periodicity of lubricant change.

- 1 - Stop the pump.

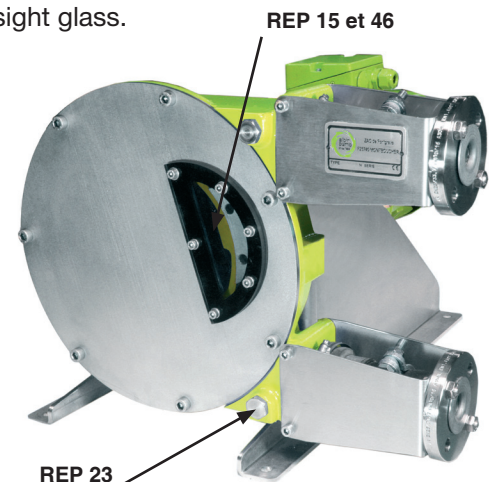

2 - Place a tray underneath the drain plug REF23.

3 - If necessary, install a tap and a drain circuit instead of the drain plug REF23.

4 - Make sure that this tray can contain the quantity of lubricant during the drainage process (see lubricant volume table §9.5).

5 - Unscrew the plug REF23 and undertake emptying.

6 - Position and tighten the plug REF23 by applying Teflon® band or waterproof paste or close the drain tap.



NOTE : If the pump is mounted with the inlet/outlet positioned upwards, lubricant drainage is obtained by unscrewing some cover screws in the lower part.

7 - Remove the sight glass REF15 as well as its seal REF46 and fill the casing with the ALBIN lubricant (see lubricant table §9.5.). You can also fill the casing by the breather cap REF52 situated at the back of the pump casing. The required lubricant level is underneath the bottom edge of the sight glass (see photo beneath).

FOR MODELS ALH05, 10, 15 et 20 :

Unscrew higher breather plug REF52 of the pump. Place a funnel inside the plug hole and fill the casing with the ALBIN lubricant (see lubricant table §9.5.). The necessary volume of lubricant is just underneath the shaft line.

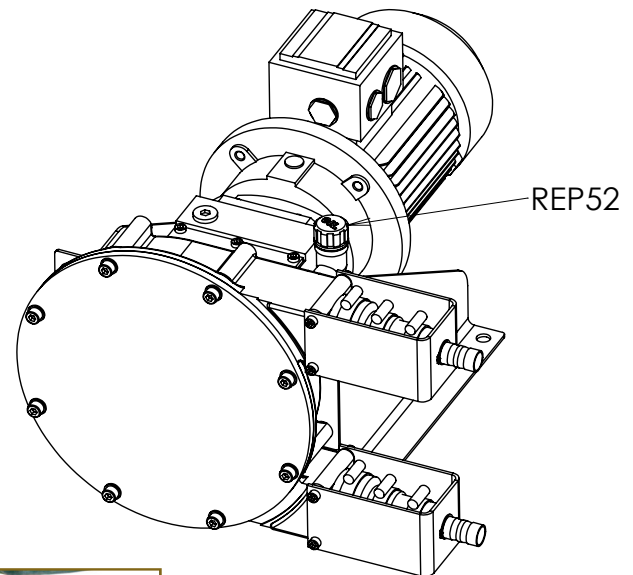

8 - Check the state of the seal REF46 and reassemble the sight glass REF15 or tighten the breather cap REF52.

MAX LEVEL

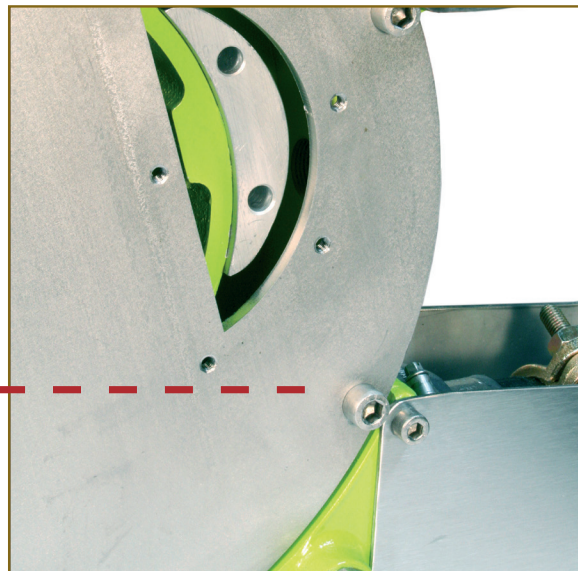

6.2 - HOSE CLEANING

The hose cleaning can be done without removing the hose. It can be done with water or with a cleaning liquid (check compatibility with hose material). With numerous products, it is necessary to clean the hose after every pumping in order to avoid the hardening of the product inside this one.



CAUTION ! Make sure that the cleaning liquid temperature is adapted to the hose material.

6.3 - HOSE REPLACEMENT



CAUTION ! Before any hose change, check the following points :

- a. This service has to be performed by skilled personnel that is acquainted with this manual.
- b. Isolate the pump from the power supply. Inlet and outlet valves have to be closed to minimize product loss.
- c. Always carry clothes and necessary protection according to the pumped product.
- d. Respect all security and enviromental rules necessary for the manipulation of the pumped product.

6.3.1 - HOSE REMOVAL

- 1 - Disconnect and remove the suction and discharge piping.
- 2 - Drain the lubricant as explained in §6.1.
- 3 - At the suction end, loosen clamps REF8 and 9 (photo 1).
Extract the insert REF12 and remove the flange REF47 (photo 2).

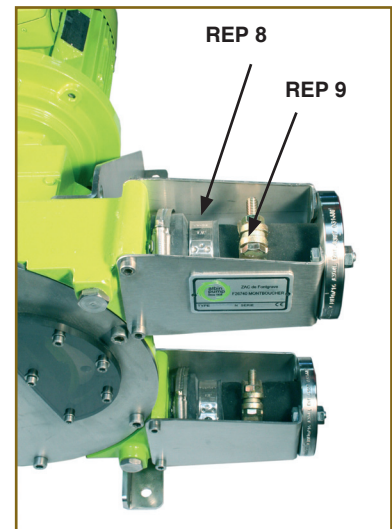

PHOTO 1

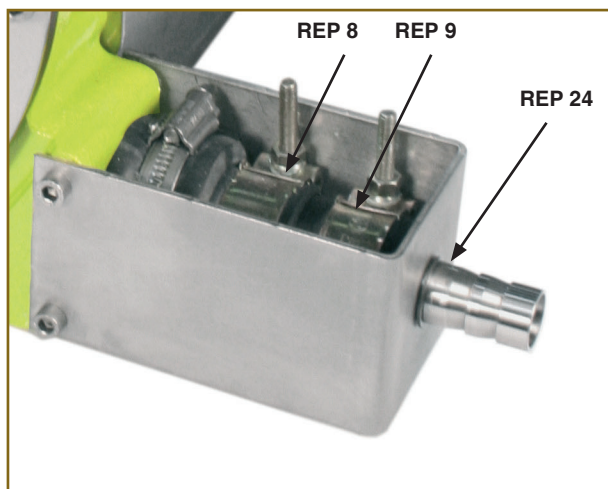

PHOTO 3

FOR MODELS ALH05, 10, 15 et 20 :

Remove circlips REF24 and dismantle bracket REF18. Extract insert REF12.

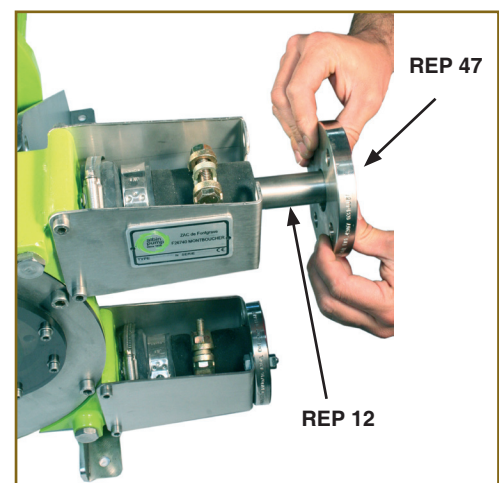

PHOTO 2

4 - At the discharge end, loosen clamps REF8 and 9. Extract the insert REF12 and remove the flange REF47 as well as the brackets REF18 (photograph 4). Remove clamps REF8 and 9 (photograph 5).

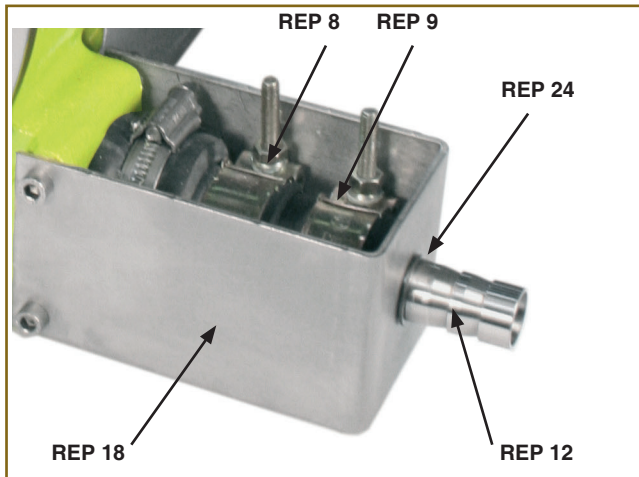

PHOTO 7

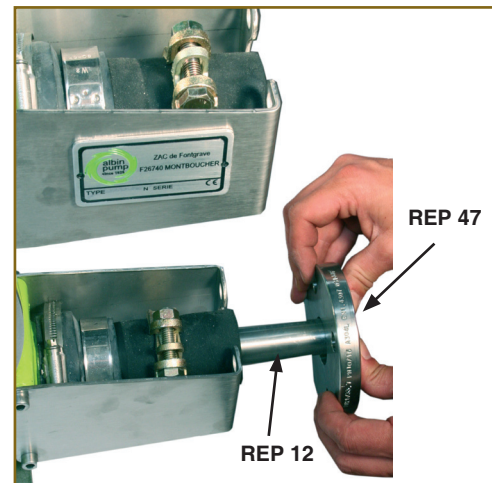

PHOTO 4

FOR MODELS ALH05, 10, 15 et 20 :

At the pump outlet, loosen clamps REF8 and REF9. Remove circlips REF24 and dismantle bracket REF18. Extract insert REF12. Remove clamps REF8 and REF9.

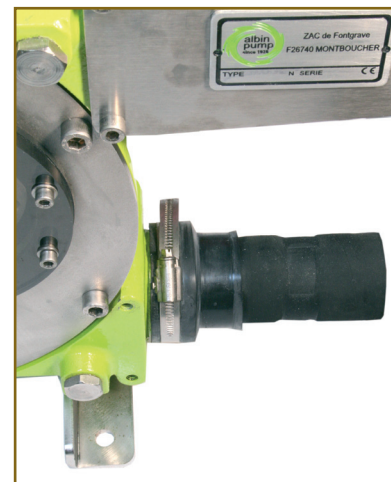

PHOTO 5

5 - Jog run the motor to deliver the hose from the pump casing at the outlet side.



WARNING ! The hose can come out of the pump casing very fast and cause harm. Check that nobody is in front of the pump's orifices while removing the hose.

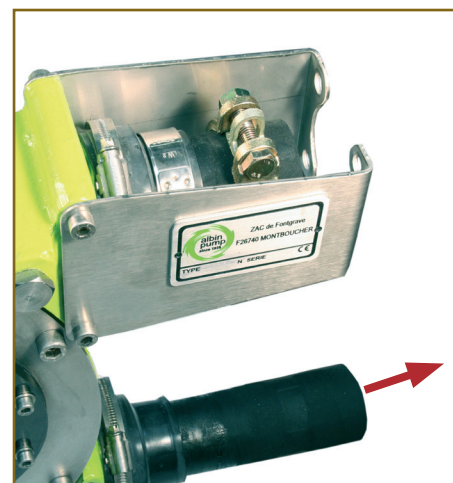

PHOTO 6

6.3.2 - PUMP CASING CLEANING

This operation is necessary when a hose has burst and when the product has contaminated the inside of the pump casing.

1 - Unfasten cover screws by leaving two screws partly fastened to the casing. Slightly withdraw the cover from the casing and fix a shackle in one of the cover's highest fastening holes (see picture below). Pumps ALH80, 100 and 125 are equipped with a lifting ring. Install a lift equipment in this shackle and slightly raise the cover. Unfasten the remaining screws and withdraw the cover.

2 - Check the state of the cover seal REF10 and replace if necessary.

3 - Check the state of wear of the pressing shoes REF5 and replace them if necessary (see §6.4 Replacement of spare parts).



CAUTION ! A wear of shoes can cause problems to the pump and provoke abnormal hose lifetime.

4 - In the case of a hose burst, it is possible that the shaft seal REF26 as well as the seal ring REF27 have been notably damaged when pumping an abrasive liquid. Relate to §6.4 if a replacement of these parts is necessary.

5 - Wash the casing with clear water and withdraw any residues.

6 - Dry the pump casing entirely.

7 - Replace the cover seal in its groove.

8 - Reassemble the pump cover.

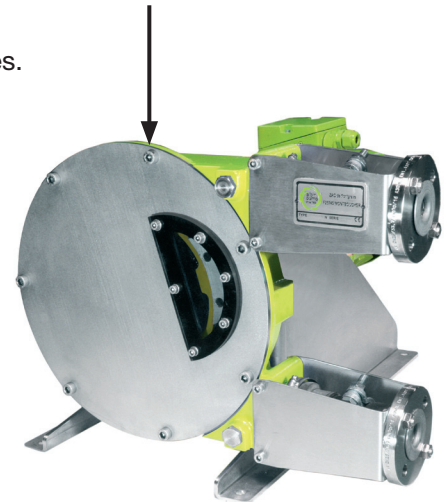

6.3.3 - REASSEMBLY OF THE HOSE



WARNING ! You should never assemble a new hose without a mounted cover.

1 - Pre-assemble the flange REF47 at the inlet port with two bolts (photo 1).

FOR MODELS ALH05, 10, 15 et 20

Temporarily mount the bracket REF18 at the inlet port.

2 - Clean the new ALBIN hose carefully. Slightly coat it with ALBIN lubricant. Slightly lubricate the inside of the sleeve REF6



PHOTO 1

- 3 - Insert the hose by the outlet port REP6 (Photo 2).
- 4 - Reverse the direction of rotation of the motor.
- 5 - While pushing on the hose, jog run the motor and check the direction of rotation.
- 6 - The shoes mounted on the wheel are going to “swallow” the hose and push it out of the inlet port. Always by giving jolts, bring the hose against the flange REF47 (photo 3).
- 7 - Assemble the clamps REF8 and 9 on the inlet side. Mount the insert REF12 into the hose. Tighten clamps REF8 and 9.

FOR MODELS ALH05, 10, 15 et 20

Dismantle the bracket REF18. Mount clamp REF8 and 9 on the hose. Mount the insert REF12 into the hose. Fix bracket REF18 and block the insert with circlips REF24. Tighten the clamp REF 8 and 9.

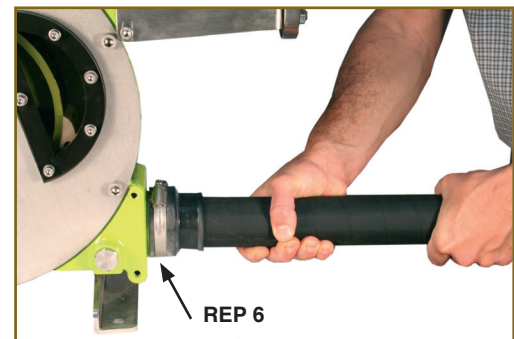

PHOTO 2



If you meet difficulties in introducing inserts into the pump hose, coat them slightly with ALBIN lubricant. Never use another lubricant.

- 8 - Assemble the brackets REF18 and pre-assemble flange REF47 on the outlet side with two temporary bolts.

FOR MODELS ALH05, 10, 15 et 20

Assemble the bracket REF18 at the outlet side.

- 9 - Reverse the direction of rotation of the motor.
- 10 - Jog run the motor to bring the hose against the discharge flange.
- 11 - Undertake operation 7 at discharge side.
- 12 - Fill the pump with the necessary quantity of ALBIN lubricant (see §6.1. and §9.5.).
- 13 - Take away the temporary flange bolts and fix the piping on both suction and discharge sides.
- 14 - Open the valves at the suction and discharge sides.
- 15 - Check the direction of rotation of the pump. Check for any possible lubricant leakage by the inserts, sleeves or cover.



PHOTO 3

6.4 - REPLACEMENT OF SPARE PARTS

6.4.1 - REPLACEMENT OF PUMP SHOES (EXCEPT ALH05, 10, ALH15, ALH20)

- 1 - Jog run the motor and position one of the shoes in front of the sight glass.
- 2 - Cut the power supply.
- 3 - Drain the lubricant (see §6.1).
- 4 - Remove the pump cover REF2 as well as the cover seal REF10.
- 5 - Disassemble the shoe which is not in contact with the hose and put aside the shims if any. Check that the pin REF30 is still on the wheel (ALH25 to ALHX80).
- 6 - Mount a new shoe on the wheel (do not to forget the washer REF29). Slide the shims between the shoe and the wheel before tightening.



CAUTION ! Be careful of the position of the shoe with the centring pin REF30 (ALH25 to ALHX80).

- 7 - Tighten the shoe onto the wheel.
- 8 - Reassemble the cover with 3 temporary bolts disposed at about 120° between each other.
- 9 - Jog run the motor 180° to bring the second shoe in front of the sight glass.
- 10 - Remove the cover once again and undertake operations 5 - 7.
- 11 - Reposition the cover and tighten all cover screws.

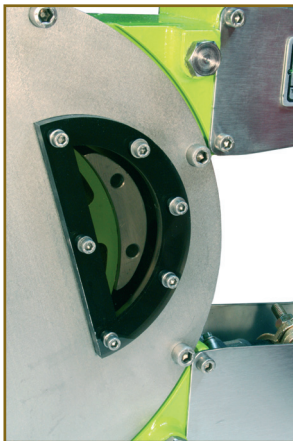

6.4.2 - REPLACEMENT OF THE SEAL RING REP27 AND THE SHAFT SEAL REP26

ALBIN hose pumps are equipped with a leakage channel that allows to see the wear of the seal ring or the shaft seal. This channel is at the back of the pump casing underneath the gearbox flange. It also protects the gearbox seals by leaving the lubricant or the product to pass freely at the back of the pump casing.

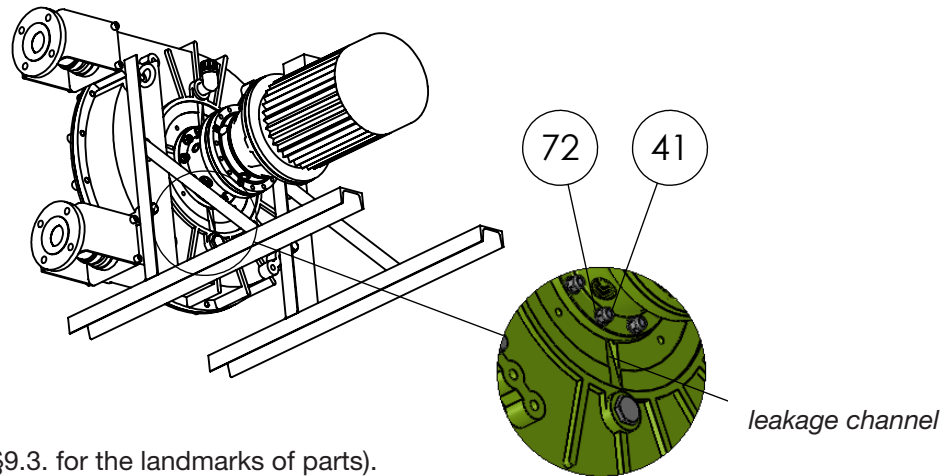

PUMPS ALH05 à ALH65

(refer to the nomenclature §9.3. for the landmarks of parts).

- 1 - Isolate the pump from the power supply.
- 2 - Empty the lubricant and clean out the pump (see §6.1).
- 3 - Remove the pump hose (see §6.3.1).
- 4 - Disassemble the pump cover and withdraw the cover seal REF10.
- 5 - Disassemble the wheel by unscrewing the expansible hub REF19. Refer to section 9.10 for expansible hub assembly and disassembly.
- 6 - Withdraw the wheel of the pump shaft with a suitable lifting equipment.
- 7 - Support the gear motor with a suitable lifting equipment.
- 8 - Unscrew the nuts REF41 and withdraw the gearbox from the pump casing.
- 9 - Extract the damaged seal ring REF27.
- 10 - Slip on the spacer ring REF73 if necessary and glue to the shaft. Position the new seal ring REF27 against the spacer ring or the gearbox shaft's shoulder. Fill the gap between the keyway and the seal ring with silicone mastic to ensure correct.



For Pumps ALH100 and ALH125 the wheel is automatically positioned by the spacer ring and seal ring. Therefore, no adjustment is necessary.

- 11 - Withdraw the shaft seal REP26 with a drift punch.
- 12 - Replace a new shaft seal REF26 with an appropriate tool (wooden or plastic cylinder). Check the mounting position of the seal (opened side turned to the cover).

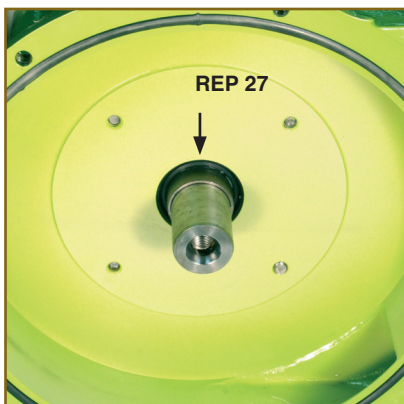

13 - Mount the gear motor on the casing being careful not to damage the shaft seal. Tighten the nuts REF41 with their washers REF72.

14 - Mount the wheel and hub on the pump shaft by positioning it referring to the table and the drawings below



REP 19

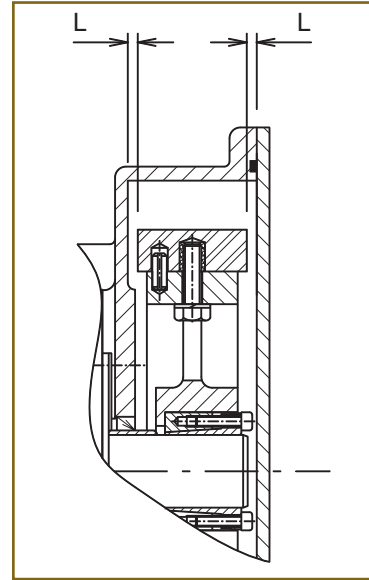

PUMP	ALH 05 - 10	ALH 15 - 20	ALH 25	ALH 32	ALH 40	ALH X40	ALH 50 - 65	ALH X80	ALH 80	ALH 100	ALH 125
Distance casing / shoe (L)	4 mm	2,75 mm	5,5 mm	6 mm	2,5 mm	5 mm	3 mm	6,5 mm	8 mm	10 mm	15 mm
Tolerance + or -	0,5 mm	0,5 mm	0,5 mm	0,5 mm	0,5 mm	0,5 mm	0,5 mm	0,5 mm	0,5 mm	0,5 mm	0,5 mm

15 - Cross tighten the expansible hub with a dynamometric spanner to the correct torque figures- Check the wheel position once again and re-adjust if necessary. Refer to section 9.10 for expansible hub assembly and disassembly.



PUMP TYPE	TORQUE Nm
ALH05-10-15-20	12
ALH25-32-40	13
ALHX40	27
ALH50-65	35
ALHX80	110
ALH80 (shaft Ø90)	110
ALH80 (shaft Ø100)	190

16 - Mount the cover seal REF10 in its groove and mount the cover.

17 - Mount the pump hose as stated in §6.3.3.

PUMPS ALHX80 A ALH125 (refer to the nomenclature for the landmarks of parts §9.3.)

1 - Undertake the same operations 1 to 10 as for pumps ALH05 to ALH65.

2 - Disassemble the seal flange REF25 and withdraw the damaged shaft seal with a screwdriver or a similar tool.

3 - Take the new shaft seal REF26 between the thumb and the index and by tightening your fingers, form an “8” figure. The seal can now be inserted into its groove by respecting the mounting position (see drawing).

4 - Mount the gear motor on the pump casing (see operation 13).

5 - Replace the O ring REF67 if necessary and reassemble the seal flange.

6 -For pumps ALHX80 and ALH80, undertake operations 14 to 17 of previous chapter. For pumps ALH100 and ALH125, undertake operation 14 of previous chapter. Then block the wheel with the washer REF60 and the screw REF59 and finish with operations 16 and 17 of previous chapter.

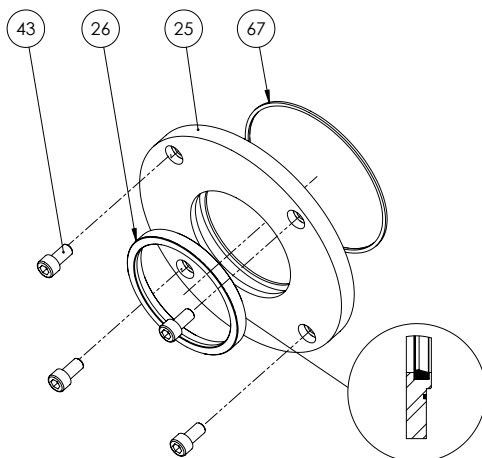

6.5 - SHOE SHIMMING



NOT : this paragraph does not concern pumps ALH05 to ALH20.



CAUTION ! The shimming of shoes is an operation which consists in adding shims under the shoe to stop any internal leakage. An internal leakage considerably reduces the life time of the hose as well as the flow. As a result, it is essential to adjust the shoe's shimming according to the rotation speed of the pump, the desired discharge pressure and the liquid viscosity.



WARNING ! Never run the pump without the sight glass.

The shoe shimming can be made without disassembling the hose or the cover. Shims are inserted or withdrawn by the sight glass as pointed out below :

- 1 - Jog run the motor and bring a shoe in front of the sight glass.
- 2 - Cut the power supply of the pump.
- 3 - Unscrew the sight glass bolts and withdraw taking care in not damaging the seal.
- 4 - Slightly unscrew the shoe's fastening bolt(s) and lift the shoe off the wheel with a screwdriver or a similar tool.
- 5 - You can now either slide in or withdraw the necessary number of shims under the shoe.



Consult the shimming table §9.6 to determine the precise number of shims according to your application.

- 6 - Tighten the shoe bolts.
- 7 - Reassemble the sight glass with its seal.
- 8 - Re-connect and jog run the motor to bring the second shoe in front of the sight glass.
- 9 - Cut the power supply of the pump.
- 10 - Repeat operations 3, 4, 5, 6 and 7. Replace the sight glass seal REF46 if necessary.

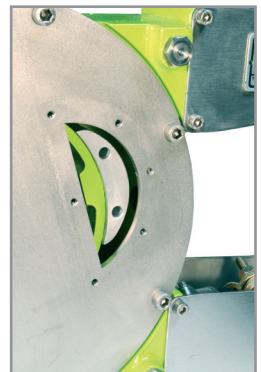
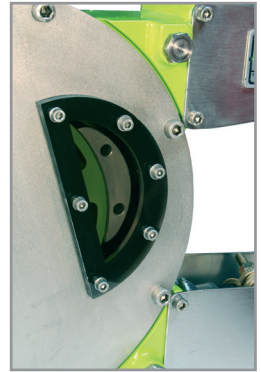

6.6 - MAINTENANCE AND PERIODIC INSPECTIONS ALH AND ALS SERIES

1	Pump hose replacement.	In prevention, change the pump hose after 90 % of the life time of the first hose.	see §6,3
2	Lubricant replacement.	At the end of two hose changes or 5000 hours of functioning. Otherwise, in every hose break.	see §6,1
3	Gearbox oil replacement.	Refer to the gearbox maintenance manual provided with the pump.	
4	Replacement of the seal ring REF27.	In case of presence of lubricant in the leak channel.	see §6,4,2
5	Replacement of the shaft seal REF26.	In case of presence of lubricant in the leak channel.	see §6,4,2
6	Replacement of the shaft seal REF105 and REF106 (ALHS series).	In case of presence of oil in the leak channel or at the lip seals.	see §6,4,2 and §6,6
7	Replacement of the shoes.	If these are worn on the contact surface.	see §6,4,1
8	Replacement of the cover seal REF10.	In the case of a leak around the pump cover.	see §6.3.2
8	Replacement of the sleeves REF6.	If these are damaged.	Refer to §6,3. Perform operations 1, 2, 3 and 4 of §6,3,1 and change sleeves. Respect directives of security.
9	Replacement of the bearings REF103 and REF104 (ALHS series)	If there are abnormal noises coming from the bearing case.	see §6,4 and §6,6
9	Check the lubricant level.	Before starting the pump and periodically during the pump service.	see §6,1
10	Check for lubricant leakage at the leakage channel.	Before starting the pump and periodically during the pump service.	see §6,4
11	Check the pump casing to discern possible leakages around the cover, the sight glass, the flanges and the sleeves.	Before starting the pump and periodically during the pump service.	
12	Check for wear on the shoe's pressing surface.	At every hose change.	see §6,4
13	Check the presence of a gearbox oil leakage.	Before starting the pump and periodically during the pump service.	see §3.5
14	Check for strange noises coming from the pump, gearbox and bearing case or abnormal pump casing temperature.	Periodically during the pump service.	

6.7 - ALHS SERIES COMPLEMENTARY INFORMATION

6.7.1 - SET UP

Before the setup of the pump, check the following points :

- The ALHS pump is delivered without a frame. Assembly holes are at the back of the pump for assembly on a frame. Dimensions of these assembly holes can be found in § 9.2 I. The pump with its drive and frame must be fixed to a solid base with a slope which does not exceed 5mm for 1m and must be firmly fastened to this one.
- The pump frame must be built in order to support the stress and deformations delivered by the pump and drive. It should be built by qualified staff with good engineering practice. In no case ALBIN PUMP AB is responsible for it's construction or conception.
- The alignment of pump and drive shafts must be made in accordance with instructions given by the manufacturer of the coupling. Refer to the specific notice of such material. To achieve alignment and coupling, use a perfectly straight ruler to control the misalignment, and a feeler gauge for angular misalignment. Control four points (top, bottom, left, right) at each stage of the installation (after setting on foundations, after fixing pipes and after a first start).
- Make sure there is enough room around the pump to carry out maintenance. If that was not the case, envisage the moving of the pump in a space provided for this purpose.
- Make sure the room is adequately ventilated to relieve the heat generated by the pump. Leave a space behind the motor ventilator hood so as not to obstruct the air intake.

6.7.2 - PUMP STARTING

Follow the steps described in §5. The hose is not mounted on bare shaft pumps when delivered. Therefore, hose mounting operations should be followed before the starting up.

6.7.3 - BEARING CASE DISMANTLING AND LIP SEAL POS26 REPLACEMENT

Carry out operations described in §6.4.2. Disassemble the bearing case in the same way as for the gearbox.

- 1 - Remove lip seals POS105 and POS106 from the bearing case.
- 2 - Remove the circlips POS 107.
- 3 - Remove the shaft with the bearings.
- 4 - Carry out the disassembly of the bearings and replace them together with the shaft POS102 if necessary.
- 5 - Remonte the shaft and the bearings, circlips and O rings. Feel up the bearing box with grease through the greaseer positioned on the top of the box.

6.7.4 - MAINTENANCE AND PERIODICAL CONTROLS

Regularly check the absence of greasee coming from the leakage channel or from the lip seal POS106.

7/ STORAGE

7.1 - STORAGE OF THE PUMP

Store the pump in a sheltered and dry place and ensure that the storage room temperature is between - 20°C and +45°C. Protect the pump if necessary and block the inlet and outlet orifices : if the pump stays without working more than 1 month, withdraw the hose from the pump or withdraw one of the shoes as well as its centring pin and position the wheel so that the second shoe can be seen threw the sight glass. For models ALH05-10-15-20, position the wheel so that one of the cam lobes remains submerged in the lubricant. If you can neither withdraw the hose or one of the shoes, run the pump 5min a week.

7.2 - STORAGE OF THE PUMP HOSES

Hoses must be stored sheltered from light in a cool place. Their life is reduced after two years. The performance of hoses is reduced at the end of this expiry date due to the ageing of rubber.

8/ TROUBLESHOOTING.

PROBLEM	POSSIBLE REASON	RESOLUTION
The pump does not work	No power supply.	Check that the pump power switch is on position "ON".
		Check the connection of the motor.
	The wheel of the pump stalls.	Check the fixing of the hose.
		Check that the discharge pressure is not too high.
		Check that the product hasn't sedimentated in the hose.
The lubricant level detector has been operated.	Check the reason for which the level detector has been operated. Check the correct functioning of this one. If the pump hose has bursted, undertake the replacement of the pump hose.	
Low capacity or pressure	Not enough Shims under shoes.	Add the sufficient number of shims.
	Air leak at the inlet of the pump.	Check the tightening of the clamps of the pump and the sealing of the inlet piping.
	Valve closed or partly closed at inlet.	Fully open the valve.
	Wear of the hose.	Replace the hose.
	Product too viscous or too high pump speed in comparison with the product viscosity.	Ask for advice from your Albin distributor.
	Piping blocked or partly blocked at inlet.	Unblock piping at inlet and make sure of the good flow of the product.

(8/ TROUBLESHOOTING.)

PROBLEM	POSSIBLE REASON	CORRECTION
Hose life is too short.	Incompatibility of the hose with the pumped product.	Make sure the compatibility of the hose with your product and contact your Albin distributor.
	Discharge pressure too high.	Check that the discharge pressure of the pump does not exceed 15 bars (or 8 bars for ALH05 to ALH20). Check that the outlet piping is not blocked up and that all valves are opened. Make sure that the security valve works correctly. Make sure that the piping friction losses do not exceed the value requested for an appropriate functioning of the pump.
	Pump speed too high.	Reduce the pump speed.
	Wrong shimming.	Check the shimming.
	Too high temperature of the product.	Contact your Albin distributor.
Lubricant leakage around the cover	Deficient tightening of cover bolts. Wear of the cover seal.	Tighten cover bolts. Replace cover seal.
Lubricant leakage in the leakage channel (underneath the gearbox flange)	Wear of the shaft seal or the seal ring.	Replace these parts.
Lubricant leakage at the sleeves	Deficient tightening of clamps or spoilt sleeve (s).	Tighten clamps or replace sleeves.
Pulsations in piping.	Deficient fastening of the piping.	Fix piping correctly.
	Process creating important pulsations due to the product, the speed of the pump, discharge pressure or the sizing of piping.	Contact your Albin distributor.
Greasee leakage (ALHS series).	Worn lip seals	Replace the lip seals REF105 and REF106. See §6.4 and §6.6.
Abnormal noise coming from the bearing case (ALHS series).	Lack of lubricant in the bearing case. Worn bearings.	Refill the bearing case with appropriate greasee. Replace bearings. See §6.4 and §6.6.

9/ CHARACTERISTICS AND TECHNICAL SPECIFICATIONS

9.1 - PERFORMANCES CURVES

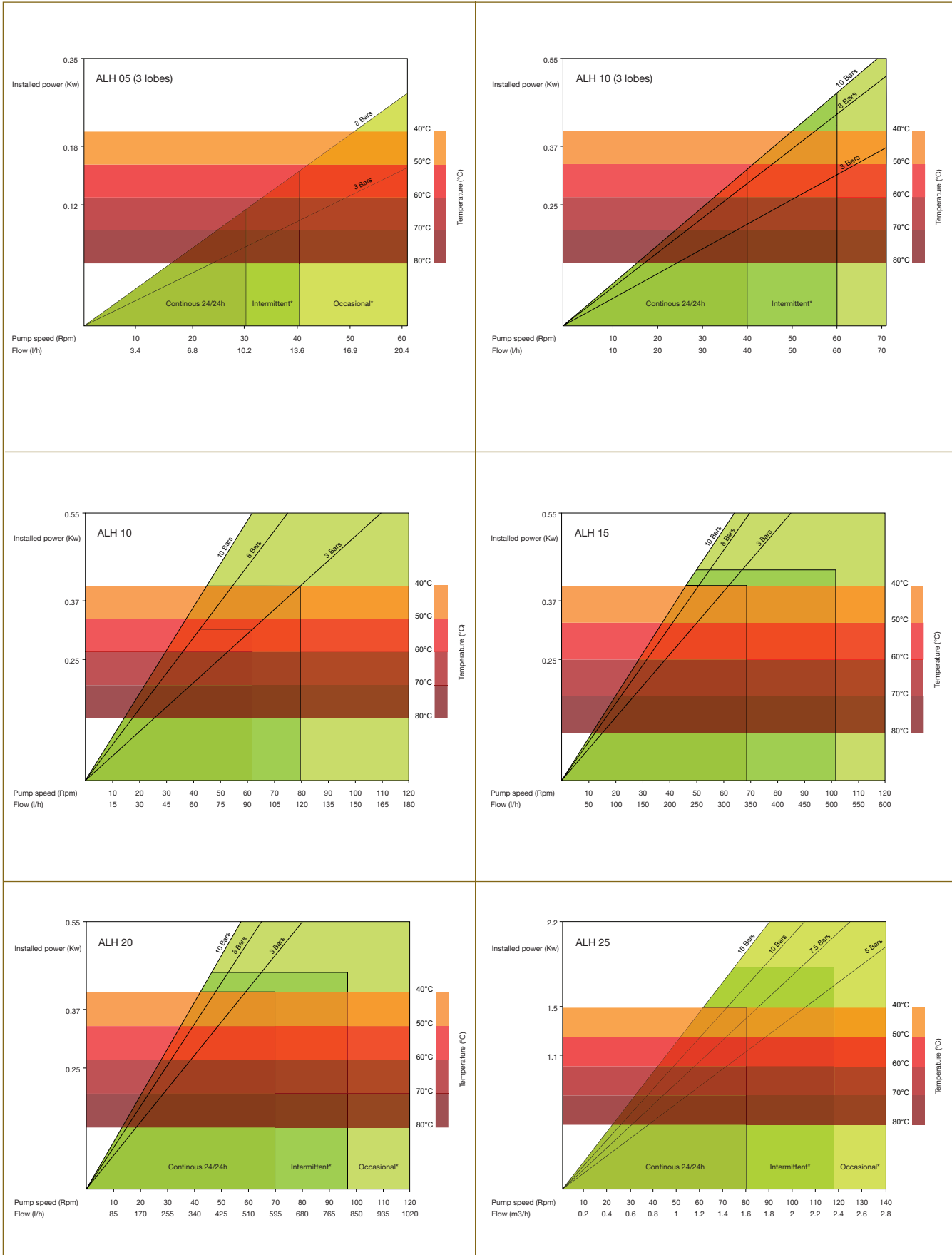

(9/ CHARACTERISTICS AND TECHNICAL SPECIFICATIONS)

9.1 - PERFORMANCES CURVES

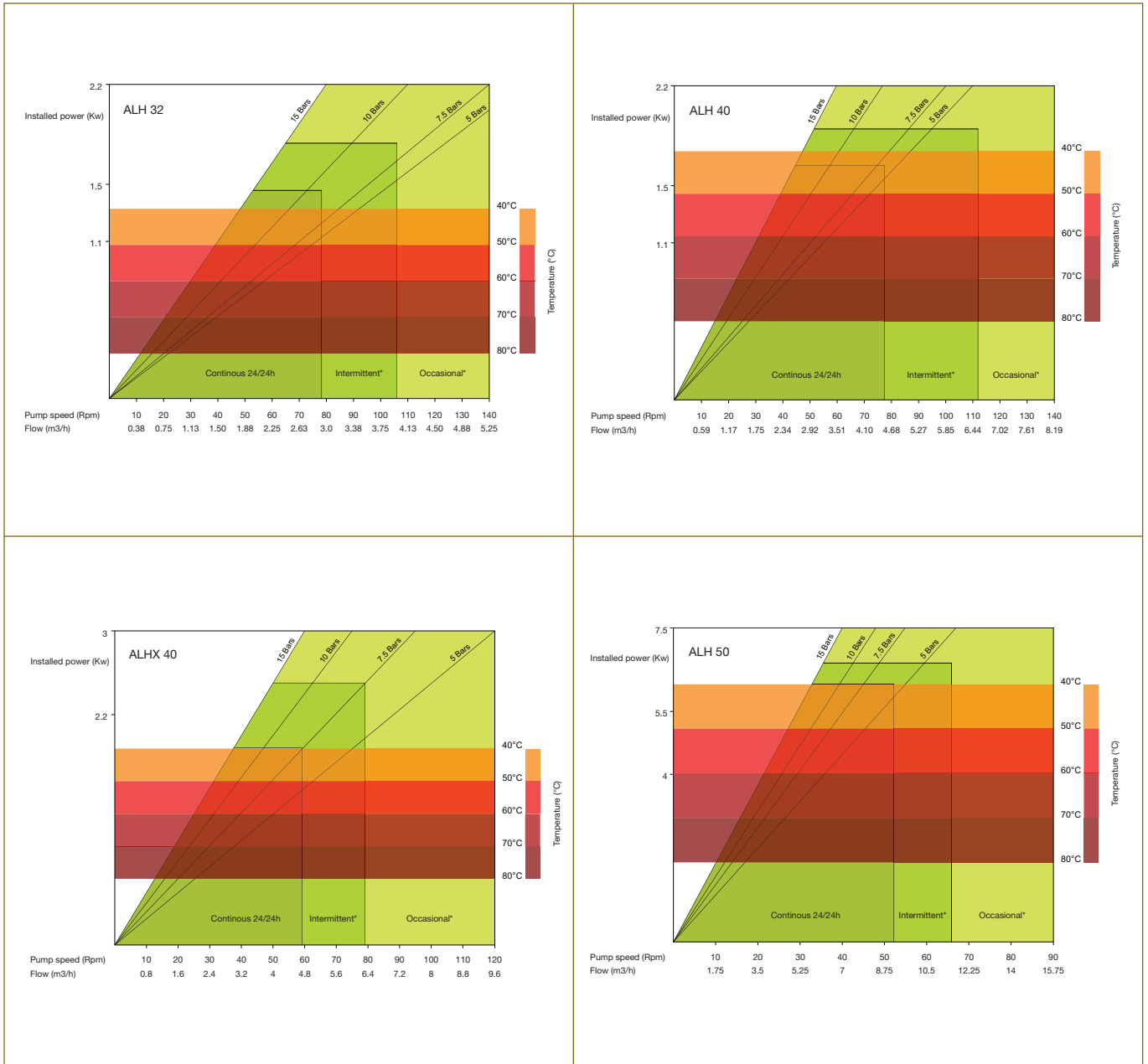

(9/ CHARACTERISTICS AND TECHNICAL SPECIFICATIONS)

9.1 - PERFORMANCES CURVES

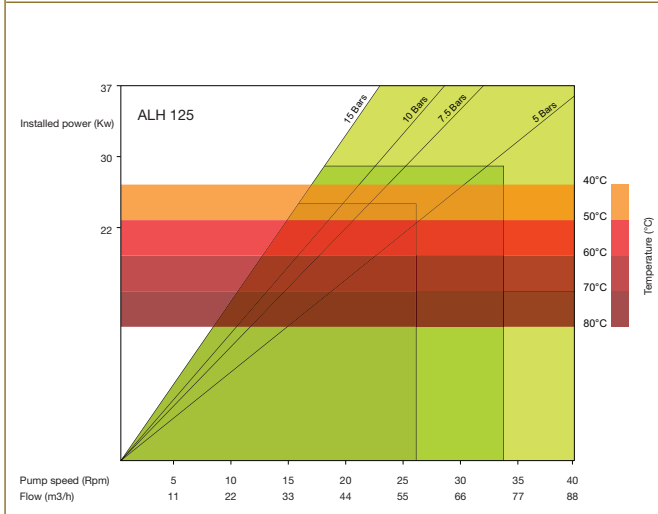
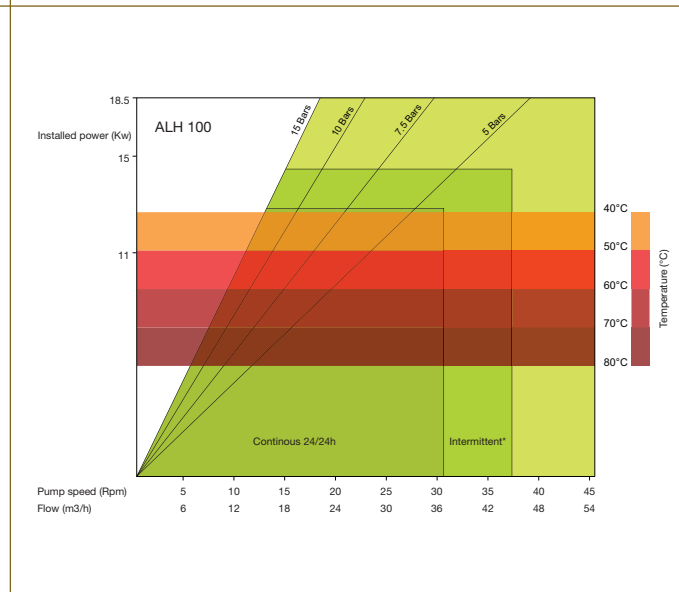
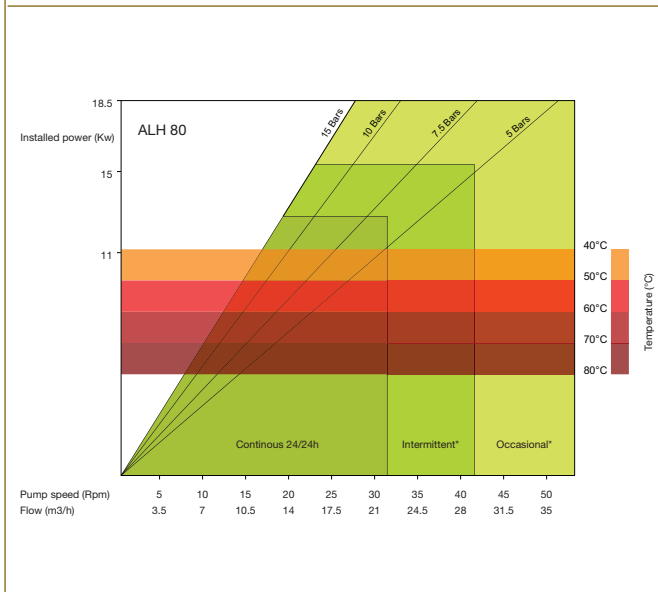
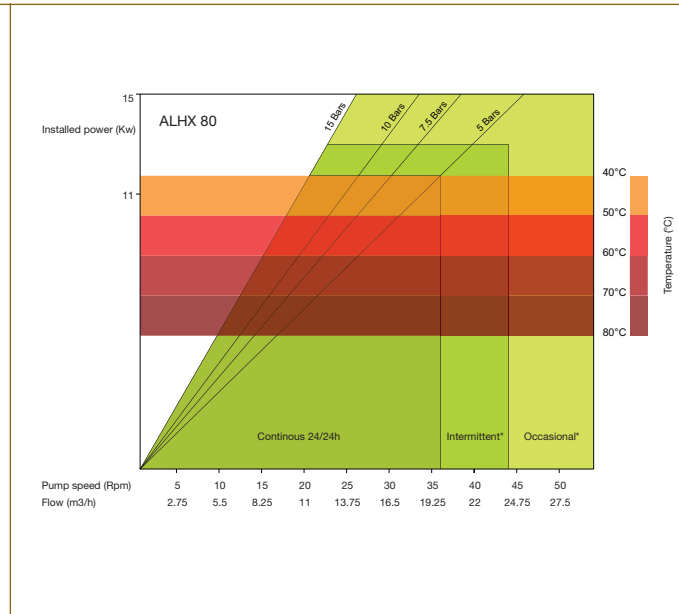
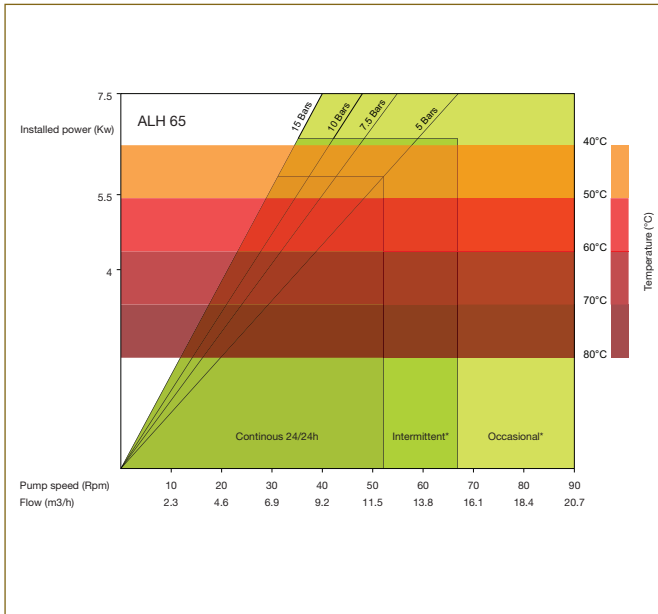

9.2 - ALBIN PUMP DIMENSIONS ALH05 TO ALH125 FLANGED GEAR MOTOR AND ALHS SERIES

PUMPS ALH05 -10 AND ALH15 -20

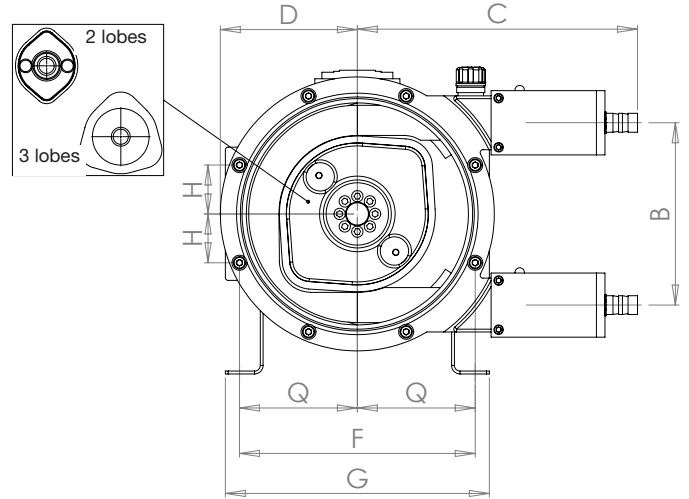
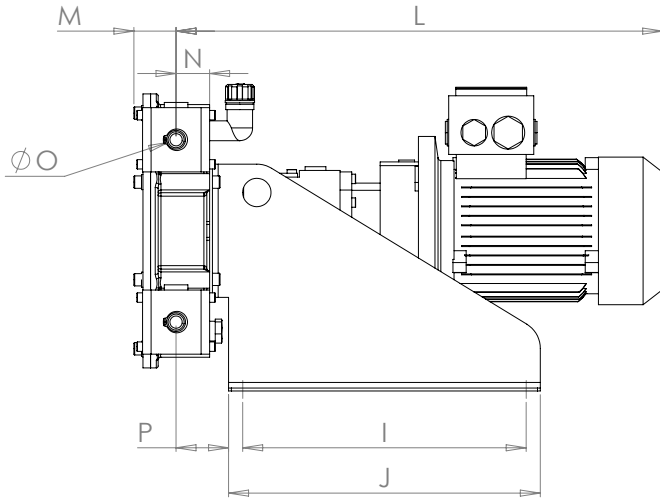

PUMPS ALH15 -20

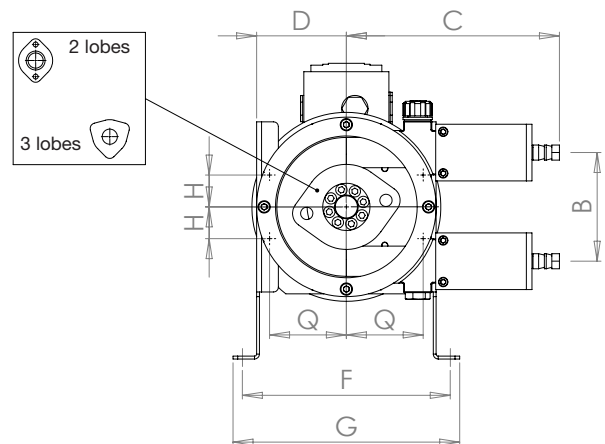
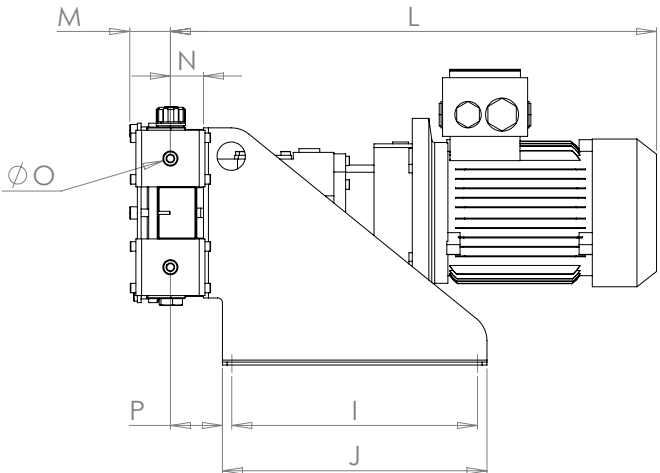

PUMPS ALH05 -10

	A	B	C	D	E	F	G	H	I	J
ALH05-10	103,5	115	226	95	256	220	240	33,5	260	280
ALH15	73	193	296	145	322	250	280	51,75	300	330
ALH20	73	193	296	145	322	250	280	51,75	300	330

	K	L	M	N	O BARB CONNEXION	P	Q
ALH05-10	4xø9	-	46,5	34,5	ø16 *	56	81,25
ALH15	4xø13	-	49	35,5	ø20 *	68,8	124,75
ALH20	4xø13	-	49	35,5	ø25 *	68,8	124,75

PUMPS ALH25 TO ALH125

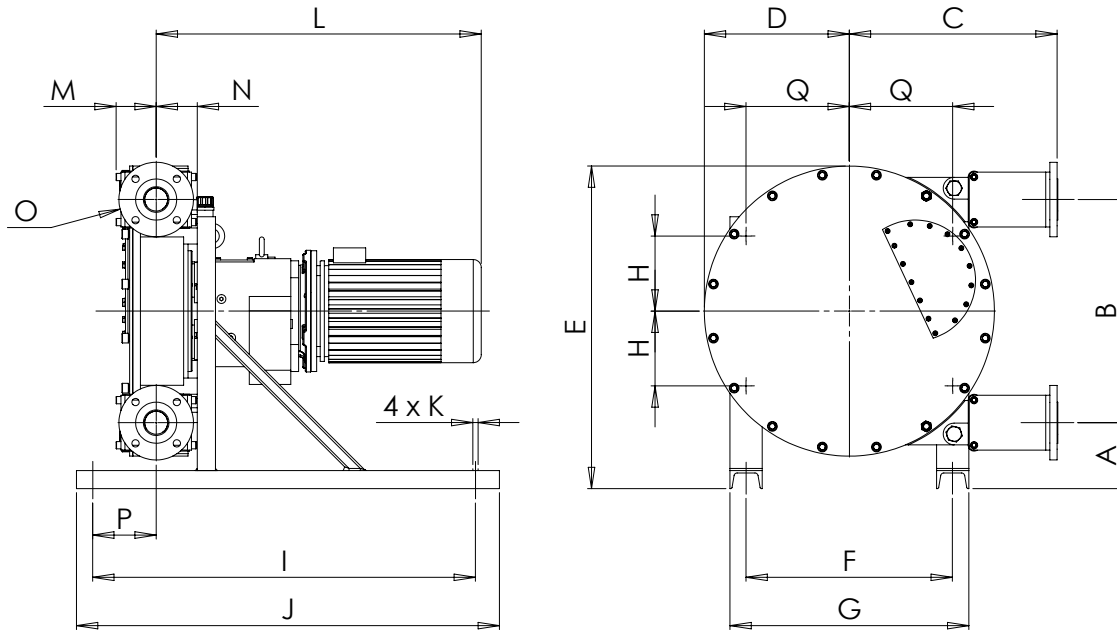

	A	B	C	D	E	F	G	H	I	J
ALH25	95	262	355,5	190	416	311	351	110	560	600
ALH32	122,5	330	435,5	238	525,5	426	476	157,75	770	810
ALH40	122,5	330	435,5	238	525,5	426	476	157,75	770	810
ALHX40	110	430	400	291	616	340	420	170	850	950
ALH50	164,5	554	517,5	360	801,5	513	593	186,5	950	1050
ALH65	164,5	554	517,5	360	801,5	513	593	186,5	950	1050
ALHX80	154	746	604	473	1004	580	680	290	1150	1250
ALH80	262	876	803	555	1320	690	830	345	1300	1400
ALH100	300	1040	887	685	1680	820	960	410	1900	2000
ALH125	263,5	1273	1034	785	1750	1000	1140	500	1900	2000

	K	L	M	N	O ISO FLANGE	P	Q
ALH25	4xø13	-	65	69	DN25 PN16	61	110
ALH32	4xø13	-	83	89	DN32 PN16	109	157,75
ALH40	4xø13	-	83	89	DN40 PN16	109	157,75
ALHX40	4xø19	-	75	86	DN40 PN16	87	170
ALH50	4xø19	-	100	102	DN50 PN16	152	256,5
ALH65	4xø19	-	100	102	DN65 PN16	152	256,5
ALHX80	4xø19	-	129	123	DN80 PN16	117	290
ALH80	4xø27	-	140	142	DN80 PN16	210	345
ALH100	4xø27	-	170	174	DN100 PN16	295	410
ALH125	4xø27	-	300	232	DN125 PN16	660	500

PUMPS ALHS05 TO ALHS20

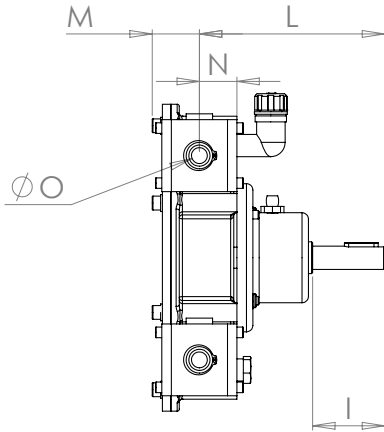

PUMPS ALHS15-20

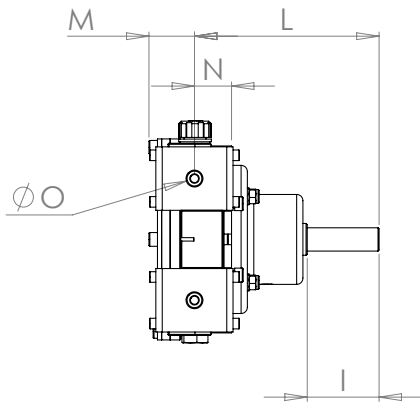
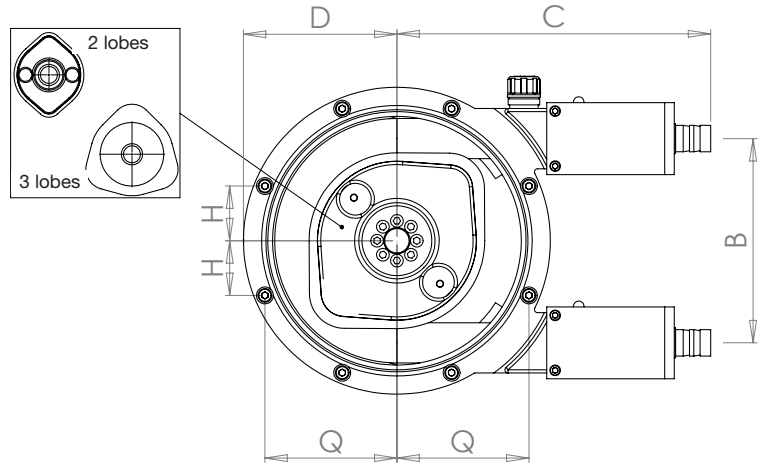

PUMPS ALHS05-10

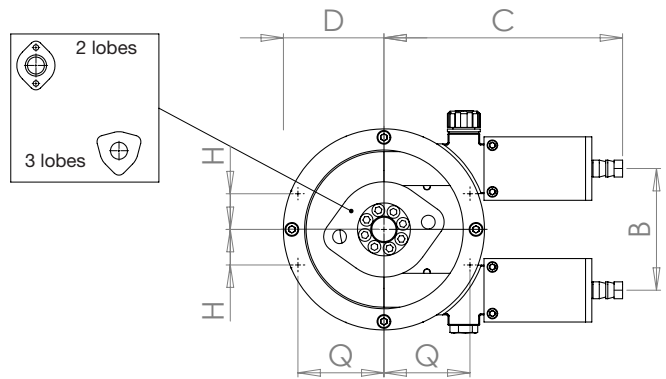

								Connections		SHAFT		FRAME FASTENINGS
	B	C	D	H	L	M	N	O BARB	Q	I	DIAMETER	
ALHS05 ALHS10	115	196	95	33.5	145	46,5	34,5	\varnothing 16mm	81.25	39	18k6	4xM8
ALHS15 ALHS20	193	259	145	51,75	175	49	35,5	\varnothing 20mm \varnothing 25mm	124.75	45	22k6	4xM8

PUMPS ALHS25 TO ALH125

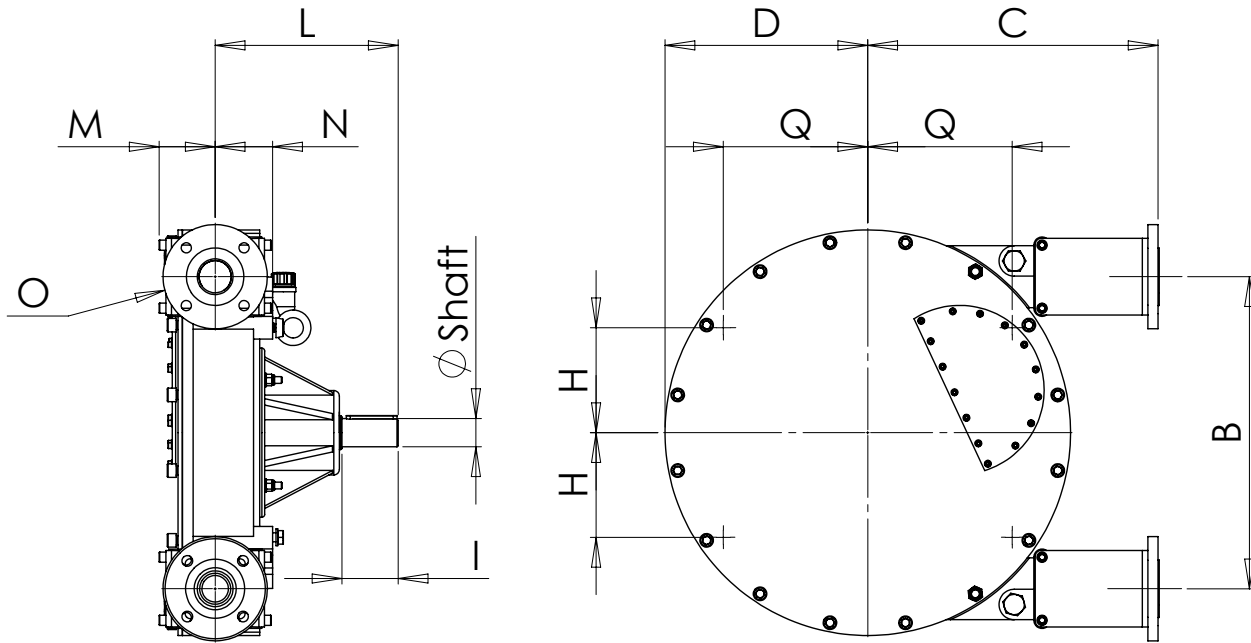

								Connections	SHAFT			FRAME FASTENINGS
	B	C	D	H	L	M	N	O ISO FLANGES	Q	I	DIAMETER	
ALHS25	262	309.5	190	110	192	65	69	DN25 PN16	110	60	30k6	4xM10
ALHS32 ALHS40	330	381	238	157.75	263	83	89	DN32 PN16 DN40 PN16	133	80	40k6	4xM12
ALHSX40	430	415.5	291	170	260	75	86	DN40 PN16	170	80	40k6	4xM12
ALHS50 ALHS65	554	455	360	186.5	325	100	102	DN50 PN16 DN65 PN16	220	100	50k6	4xM16
ALHSX80	746	582	473	290	400	129	123	DN80 PN16	290	130	70k6	4xM20
ALHS80	876	730.5	555	345	440	140	142	DN80 PN16	345	150	80k6	4xM20
ALHS100	1040	817	685	410	572	170	174	DN100 PN16	410	200	100k6	4xM20
ALHS125	1273	1034	785	500	673.5	300	232	DN125 PN16	500	180	125k6	4xM24

9.3 - NOMENCLATURE

Exploded view ALH05 - ALH10

REFER TO ALH PUMP PARTS LIST FOR PART DESIGNATION

Ce document est la propriété de Albin Pump AB. Toute reproduction interdite sans autorisation expresse de Albin Pump AB.

MATERIAL:	WEIGHT:	CUSTOMER:	PUMP TYPE: ALH05-10	Code Oratio: Serial number:	 ALBIN PUMP AB Alegarsgatan 1 431 50 Mölndal SWEDEN
BRUT:	General clearance: +/-	PROJECT N°:	PART NUMBER		
DIM:			REP		
TITLE:					SIZE: A3
ALH05-10 EXPLODED VUE					REV: 1
SCALE: 1:	DWG N°: EXPLODE-ALH05-10-IND01 10-2011				

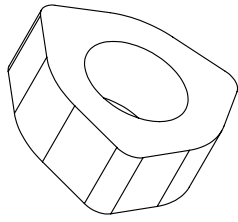

Wheel #3
3 lobe version

(9.3 - NOMENCLATURE)

Exploded view ALH15 - ALH20

Ce document est la propriété de Albin Pump AB. Toute reproduction interdite sans autorisation expresse de Albin Pump AB.

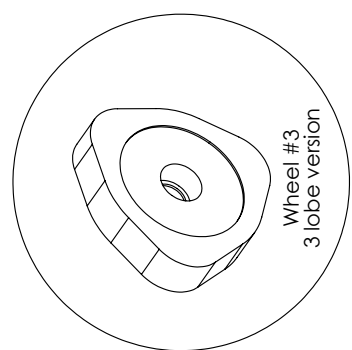
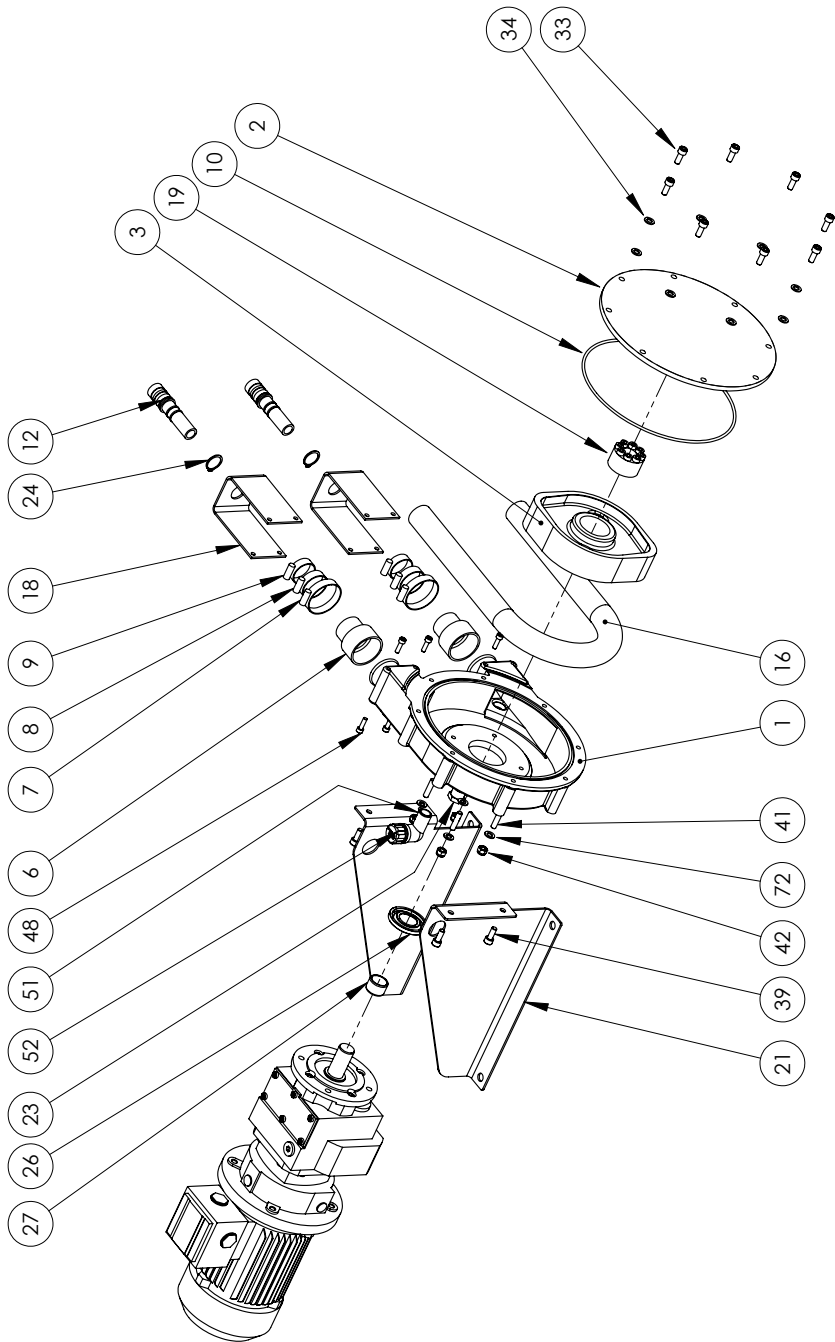

REFER TO ALH PUMP PARTS LIST FOR PART DESIGNATION

MATERIAL:	WEIGHT:	CUSTOMER:	PUMP TYPE: ALH15-20	Code Oratio: Serial number:
BRUT:	General clearance: +/-	PROJECT N°:	PART NUMBER REP	<p>ALBIN PUMP AB Ålsjögravation 1 431 50 Mölndal SWEDEN</p>
DWG N°:	EXPLODE ALH15-20/IND01 10-2011		SIZE: A3	
SCALE: 1:	TITLE: ALH15-20 EXPLODED VUE		REV: 1	

(9.3 - NOMENCLATURE)

Exploded view ALH25 - ALH40

REFER TO ALH PUMP PARTS LIST FOR PART DESIGNATION

MATERIAL: NS	WEIGHT:	CUSTOMER:	PUMP TYPE: ALH25-32-40	Code Orator: Serial number:
BRUT: DIM:	General Clearance: +/-	PROJECT N°:	PART NUMBER REP	
EXPLODED VIEW ALH25-32-40				
TITLE:	DWG N°: EXPLODE-ALH25-32-40-IND01 11-2010			SIZE: A3
SCALE: 1:				REV: 1

Ce document est la propriété de Albin Pump AB. Toute reproduction interdite sans autorisation expresse de Albin Pump AB.

(9.3 - NOMENCLATURE)

Exploded view ALHX40 - ALH65

REFER TO ALH PUMP PARTS LIST FOR PART DESIGNATION.

HELICAL GEARBOX
ALHX40: seal ring#27 only.
ALH50-65: spacer ring#73 and seal ring#27.

PLANETARY GEARBOX (ALH50-65)
seal ring#27 only.

DETAIL A

DETAIL B

MATERIAL: NS/Material: <non-spezifiek>	WEIGHT:	CUSTOMER:	PUMP TYPE: ALHX40-50-65	Code Orator:	 ALBIN PUMP AB Aleqvedgratan 1 431 50 Mölndal/SWEDEN
BRUT:	General clearance: +/-	PROJECT N°:	PART NUMBER	Serial number:	
DIM:					
ALHX40-50-65 EXPLODED VIEW					
SCALE: 1:	DWG N°: EXPLODE ALHX40-50-65 INDO1 11-2010	SIZE: A3	REV: 1		

Ce document est la propriété de Albin Pump AB. Toute reproduction interdite sans autorisation expresse de Albin Pump AB.

(9.3 - NOMENCLATURE)

Exploded view ALHX80 - ALH80

REFER TO ALH PUMP PARTS LIST FOR PART DESIGNATION.

* For ALH80 pumps only with a gearbox flange dimension. \varnothing 350/400/450
** For ALHX80 pump only.

Lifting ring on ALH80 cover.

DETAIL A

DETAIL B

DETAIL C

MATERIAL: Materiële kenmerken/specificaties	WEIGHT:	CUSTOMER:	PUMP TYPE: ALHX80-80	Code Oratio: Serial number:
BRUT:	General clearance: +/-	PROJECT N°:	PART NUMBER	<p>ALBIN PUMP AB Alegrandsgatan 1 431 50 Mölndal SWEDEN</p>
DIM:			REP	
ALHX80-80 EXPLODED VIEW				
SCALE: 1:	DWG N°: EXPLODE ALHX80-80 IND01 11-2010	SIZE: A3	REV: 1	

Ce document est la propriété de Albin Pump AB. Toute reproduction interdite sans autorisation expresse de Albin Pump AB.

(9.3 - NOMENCLATURE)

Exploded view ALH100

REFER TO ALH PUMP PARTS LIST FOR PART DESIGNATION.

Ce document est la propriété de Albin Pump AB. Toute reproduction interdite sans autorisation expresse de Albin Pump AB.

MATERIAL: Matriel: <non spécifié>	WEIGHT:	CUSTOMER:	Code Orator: Serial number:
BRUT:	General clearance: +/-	PROJECT N°:	PUMP TYPE: ALH100
DIM:	<h2 style="margin: 0;">ALH100 EXPLODED VIEW</h2>		
TITLE:	DWG N°: EXPLODE ALH100/IND01 11-2010		
SCALE: 1:		SIZE: A3	REV: 1

DETAIL A

DETAIL B

(9.3 - NOMENCLATURE)

Exploded view ALH125

REFER TO ALH PUMP PARTS LIST FOR PART DESIGNATION.

Code Oratio:
Serial number:

PUMP TYPE:
ALH125

CUSTOMER:
PROJECT N°:

WEGHT:
General Clearance: +/-

MATERIAL:
Matériau <non-spécifié>

BRUT:
DIM:

TITLE:
ALH125
EXPLODED VIEW

DWG N°:
EXPLODE ALH125 IND01 11-2010

SCALE:
1:

SIZE: A3

REV: 1

albin pump
ALBIN PUMP AB
Alegrandsgratan 1
431 50 Mölndal SWEDEN

15 38 37 34 33 35 36
46 2 10 16 60 77 59 3
9 8 7 6 23
12 47 18 22 48 51 52 76 27 73
28 4 29 5 21 1 40 39 72 74 41
79 80 81 82 83 84
26 25 67 63 78 64

DETAIL B
DETAIL A
DETAIL C

Le document est la propriété de Albin Pump AB. Toute reproduction interdite sans autorisation expresse de Albin Pump AB.

(9.3 - NOMENCLATURE)

Exploded view ALHS05 - ALHS125 bearing case

Ce document est la propriété de Albin Pump AB. Toute reproduction interdite sauf autorisation expresse de Albin Pump AB.

MATERIAL: Materiaal <non spécifiés>	WEIGHT:	CUSTOMER:	PUMP TYPE: ALHS05 to S125	Code Oratio:	 ALBIN PUMP AB Ålsjögrändsvägen 1 431 50 Mölndal, SWEDEN
BRUT:	General clearance: +/-	PROJECT N°:	PART NUMBER	Serial number:	
DWG:			REP		
TITLE: EXPLODED VIEW ALHS BEARING CASE					
SCALE: 1:	DWG N°: EXPLODE ALHS05-125 BEARING CASE IND001 12-2010	SIZE: A3	REV: 1		

DETAIL ALHSX80 to ALHS125

(9.3 - NOMENCLATURE)

Exploded view ALH hose rupture and vacuum options

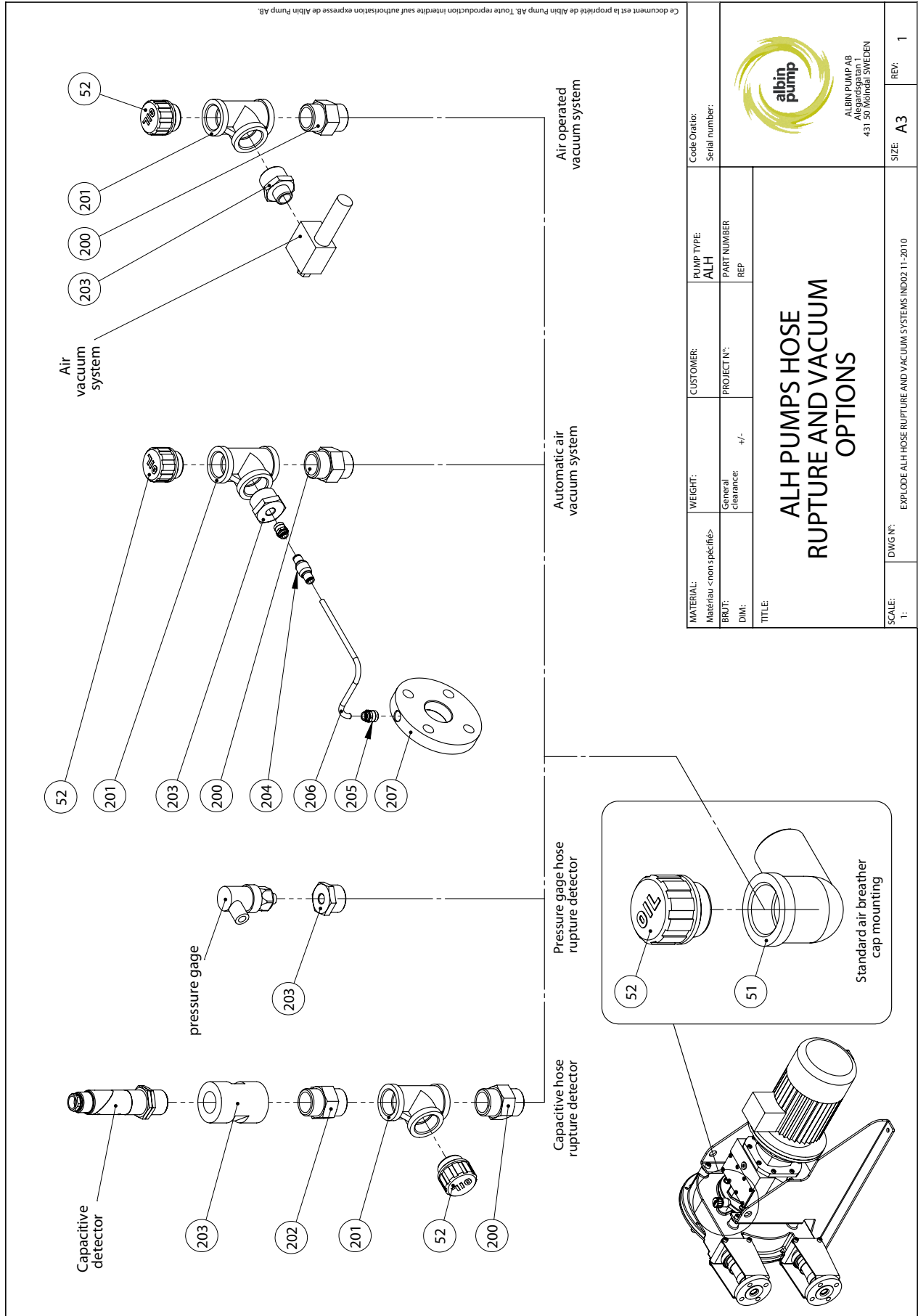

MATERIAL: Matériau «non-spécifié»		WEIGHT:	CUSTOMER:	PUMP TYPE: ALH	Code Oratio: Serial number:
BRUT:		General Clearance: +/-	PROJECT N°:	PART NUMBER REP	 ALBIN PUMP AB Alegardsgatan 1 431 50 Mölndal SWEDEN
DIM:					
<h2>ALH PUMPS HOSE RUPTURE AND VACUUM OPTIONS</h2>					
SCALE: 1:	DWG N°: EXPLODE ALH HOSE RUPTURE AND VACUUM SYSTEMS IND02.11-2010			SIZE: A3	REV: 1

9.4 - ALH PUMP PARTS LIST (see specific exploded view)

REF.	DESIGNATION	ALH 05 ALH10	ALH15 ALH20	ALH25 TO ALH40	ALHX40 TO ALH 65	ALHX80	ALH80	ALH100	ALH125
1	CASING	X	X	X	X	X	X	X	X
2	COVER	X	X	X	X	X	X	X	X
3	WHEEL	X	X	X	X	X	X	X	X
4	SHIM			X	X	X	X	X	X
5	SHOE			X	X	X	X	X	X
6	SLEEVE	X	X	X	X	X	X	X	X
7	CLAMP SLEEVE	X	X	X	X	X	X	X	X
8	CLAMP ON SLEEVE / HOSE		X	X	X	X	X	X	X
9	CLAMP ON HOSE	X	X	X	X	X	X	X	X
10	COVER SEAL	X	X	X	X	X	X	X	X
12	INSERT	X	X	X	X	X	X	X	X
14	LUBRICANT	X	X	X	X	X	X	X	X
15	SIGHT GLASS			X	X	X	X	X	X
16	HOSE	X	X	X	X	X	X	X	X
18	BRACKET	X	X	X	X	X	X	X	X
19	HUB	X	X	X	X	X	X		
20	BOLT ON PLATE					X	X		
21	FRAME	X	X	X	X	X	X	X	X
22	LIFT RING					X	X	X	X
23	OIL PLUG	X	X	X	X	X	X	X	X
24	CIRCLIPS	X	X						
25	SEAL FLANGE					X	X	X	X
26	SHAFT SEAL	X	X	X	X	X	X	X	X
27	SEAL RING	X	X	X	X	X	X	X	X
28	SHOE BOLT			X	X	X	X	X	X
29	SHOE BOLT WASHER			X	X	X	X	X	X
30	SHOE CENTERING PIN			X	X	X			
31	BOLT ON PLATE SCREW					X	X		
32	NUT FOR REF 31					X	X		
33	COVER BOLT	X	X	X	X	X	X	X	X
34	COVER BOLT WASHER				X	X	X	X	X
35	COVER STUD				X	X	X	X	X
36	NUT FOR REF 35				X	X	X	X	X
37	SIGHT GLASS BOLT			X	X	X	X	X	X
38	WASHER FOR REF 37			X	X	X	X	X	X
39	FRAME BOLT	X	X	X	X	X	X	X	X
40	WASHER FOR REF 39	X	X	X	X	X	X	X	X
41	GEARBOX STUD	X	X	X	X	X	X	X	X
42	NUT FOR REF 41	X		X	X	X	X	X	
43	SEAL FLANGE BOLT					X	X	X	X
46	SIGHT GLASS SEAL			X	X	X	X	X	X
47	INLET & OULET FLANGE			X	X	X	X	X	X
48	BRACKET BOLT	X	X	X	X	X	X	X	X
49	BRACKET BOLT WASHER								
51	90° BEND		X	X	X	X	X	X	X
52	BREATHER PLUG	X	X	X	X	X	X	X	X
59	WHEEL BOLT							X	X
60	WHEEL BOLT WASHER							X	X
63	LIFT RING ON COVER						X	X	X
64	BOLT FOR REF 63						X	X	X
67	O RING FOR SEAL FLANGE					X	X	X	X
70	GEARBOX CENTRING FLANGE						X		
71	COVER FLANGE	X							
72	WASHER for REF 41	X	X	X	X	X	X	X	X
73	SPACER RING				X (ALH50-65 D350)	X	X	X	X
74	PLUG		X	X	X	X	X	X	X
75	O RING FOR 73							X	

9.5 - ALH BEARING CASE PARTS LIST (see specific exploded view page 39)

REF.	DESIGNATION	ALH 05 ALH10	ALH15 ALH20	ALH25 TO ALH40	ALHX40 TO ALH 65	ALHX80	ALH80	ALH100	ALH125
101	BEARING CASE (ALHS)	X	X	X	X	X	X	X	X
102 103	SHAFT (ALHS)	X	X	X	X	X	X	X	X
103	ROLLAR BEARING (ALHS)	X	X	X	X	X	X	X	X
104	BALL BEARING (ALHS)	X	X	X	X	X	X	X	X
105	LIP SEAL (ALHS)	X	X	X	X	X	X	X	X
106	LIP SEAL (ALHS)	X	X	X	X	X	X	X	X
107	CIRCLIPS (ALHS)	X	X	X	X	X	X	X	X
108	GreaseER (ALHS)	X	X	X	X	X	X	X	X
109	SHAFT KEY (ALHS)	X	X	X	X	X	X	X	X
110	SHAFT KEY (ALHS)					X	X	X	X
111	PLUG (ALHS)	X	X	X	X	X	X	X	X

9.6 - HOSE RUPTURE AND VACUUM SYSTEM PARTS LIST (see specific exploded view page 42)

REF.	DESIGNATION	CAPACITIVE HOSE RUPTURE DETECTOR	PRESSURE GAGEIC HOSE RUPTURE DETECTOR	AUTOMATIC AIR VACUUM SYSTEM	AIR OPERARED VACUUM SYSTEM
51	90° BEND	X	X	X	X
52	VENT	X		X	X
200	HEXAGON NIPPLE	X		X	X
201	TE CONNEXION	X		X	
202	HEXAGON NIPPLE	X		X	
203	ADAPTOR	X	X	X	X
204	AIR SUPPLY CHECKVALVE			X	
205	AIR SUPPLY CONNEXION			X	
206	AIR SUPPLY HOSE			X	
207	VACUUM FLANGE			X	

9.7 - LUBRIFICATION TABLE

The table indicates the quantity of lubricant necessary for every pump size. Employ only the ALBIN lubricant for ALBIN hose pumps. refer to §6.2 for lubricant emptying and filling.

PUMPS	ALH 05-10	ALH 15-20	ALH 25	ALH 32	ALH 40	ALHX 40
QUANTITY OF LUBRICANT (LITERS)	0,4	0,8	1,4	2,3	2,3	6

PUMPS	ALH 50	ALH 65	ALHX 80	ALH 80	ALH 100	ALH 125
QUANTITY OF LUBRICANT (LITERS)	9	9	20	40	60	100

9.8 - SHOE SHIMMING TABLE

Refer to §6.5 to remove or add shims. The table below points out the necessary number of shims under every shoe according to the speed, pressure and the temperature of the product. Respect these indications scrupulously to optimize the hose life and to avoid a possible deterioration of the internal parts. For temperatures over 60°C, withdraw one shim in comparison with the table below. For viscosities over 3000cP or concentrations exceeding 300g / l, withdraw one shim in comparison with the table below. For a suction lift higher than 4 metres, add one shim to the following figures.



CAUTION : Every shoe must include the same number of shims (0.5mm).

PUMP TYPE ALH 25		
Pressure bar (psi)	Speed - Rpm	Number of shims
$\Delta P \leq 5$ (72,5)	0 to 40	0
	40 to 160	0
5 (72,5) $\leq \Delta P \leq 7,5$ (108,75)	0 to 40	2
	40 to 125	1
$7,5$ (108,75) $\leq \Delta P \leq 10$ (145)	0 to 40	3
	40 to 105	2
10 (145) $\leq \Delta P \leq 15$ (217,5)	0 to 40	4
	40 to 90	3

PUMP TYPE ALH 32		
Pressure bar (psi)	Speed - Rpm	Number of shims
$\Delta P \leq 5$ (72,5)	0 to 45	0
	40 to 140	0
5 (72,5) $\leq \Delta P \leq 7,5$ (108,75)	0 to 40	2
	45 to 140	1
$7,5$ (108,75) $\leq \Delta P \leq 10$ (145)	0 to 40	3
	45 to 110	2
10 (145) $\leq \Delta P \leq 15$ (217,5)	0 to 40	4
	45 to 80	3

PUMP TYPE ALH 40		
Pressure bar (psi)	Speed - Rpm	Number of shims
$\Delta P \leq 5$ (72,5)	0 to 40	0
	40 to 160	0
5 (72,5) $\leq \Delta P \leq 7,5$ (108,75)	0 to 40	2
	40 to 125	1
$7,5$ (108,75) $\leq \Delta P \leq 10$ (145)	0 to 40	3
	40 to 105	2
10 (145) $\leq \Delta P \leq 15$ (217,5)	0 to 40	4
	40 to 90	3

PUMP TYPE ALHX 40		
Pressure bar (psi)	Speed - Rpm	Number of shims
$\Delta P \leq 5$ (72,5)	0 to 55	0
	40 to 120	0
5 (72,5) $\leq \Delta P \leq 7,5$ (108,75)	0 to 55	2
	40 to 95	1
$7,5$ (108,75) $\leq \Delta P \leq 10$ (145)	0 to 55	3
	40 to 75	2
10 (145) $\leq \Delta P \leq 15$ (217,5)	0 to 55	4
	40 to 60	3

PUMP TYPE ALH 50		
Pressure bar (psi)	Speed - Rpm	Number of shims
$\Delta P \leq 5$ (72,5)	0 to 30	0
	30 to 100	0
5 (72,5) $\leq \Delta P \leq 7,5$ (108,75)	0 to 30	2
	30 to 65	1
$7,5$ (108,75) $\leq \Delta P \leq 10$ (145)	0 to 30	3
	30 to 50	2
10 (145) $\leq \Delta P \leq 15$ (217,5)	0 to 30	4
	30 to 42	3

PUMP TYPE ALH 65		
Pressure bar (psi)	Speed - Rpm	Number of shims
$\Delta P \leq 5$ (72,5)	0 to 30	0
	30 to 90	0
5 (72,5) $\leq \Delta P \leq 7,5$ (108,75)	0 to 30	2
	30 to 55	1
$7,5$ (108,75) $\leq \Delta P \leq 10$ (145)	0 to 30	3
	30 to 47,5	2
10 (145) $\leq \Delta P \leq 15$ (217,5)	0 to 30	4
	30 to 40	3

PUMP TYPE ALHX 80		
Pressure bar (psi)	Speed - Rpm	Number of shims
$\Delta P \leq 5$ (72,5)	0 to 25	0
	25 to 65	0
5 (72,5) $\leq \Delta P \leq 7,5$ (108,75)	0 to 25	2
	25 to 46	1
$7,5$ (108,75) $\leq \Delta P \leq 10$ (145)	0 to 25	3
	25 to 40	2
10 (145) $\leq \Delta P \leq 15$ (217,5)	0 to 25	4
	25 to 31	3

PUMP TYPE ALH 80		
Pressure bar (psi)	Speed - Rpm	Number of shims
$\Delta P \leq 5$ (72,5)	0 to 20	0
	20 to 60	0
5 (72,5) $\leq \Delta P \leq 7,5$ (108,75)	0 to 20	2
	20 to 47	1
$7,5$ (108,75) $\leq \Delta P \leq 10$ (145)	0 to 20	3
	20 to 37	2
10 (145) $\leq \Delta P \leq 15$ (217,5)	0 to 20	4
	20 to 31	3

PUMP TYPE ALH 100		
Pressure bar (psi)	Speed - Rpm	Number of shims
$\Delta P \leq 5$ (72,5)	0 to 15	0
	15 to 50	0
5 (72,5) $\leq \Delta P \leq 7,5$ (108,75)	0 to 15	2
	15 to 32,5	1
$7,5$ (108,75) $\leq \Delta P \leq 10$ (145)	0 to 15	3
	15 to 25	2
10 (145) $\leq \Delta P \leq 15$ (217,5)	0 to 15	4
	15 to 20	3

PUMP TYPE ALH 125		
Pressure bar (psi)	Speed - Rpm	Number of shims
$\Delta P \leq 5$ (72,5)	0 to 10	0
	10 to 35	0
5 (72,5) $\leq \Delta P \leq 7,5$ (108,75)	0 to 10	2
	10 to 27,5	1
$7,5$ (108,75) $\leq \Delta P \leq 10$ (145)	0 to 10	3
	10 to 25	2
10 (145) $\leq \Delta P \leq 15$ (217,5)	0 to 10	4
	10 to 20	3

9.9 - GENERATED NOISE AND TEMPERATURE

NOISE :

The ALBIN PUMPS do not generate more than 60dB during their operation.

TEMPERATURE :

The cover and the pump casing can become very hot due to the friction on the hose and liquid temperature. If you need to limit the pump temperature, please contact your ALBIN PUMP distributor.

9.10 - EXPANSIBLE HUB ASSEMBLY AND DISASSEMBLY : GENERALITIES

ASSEMBLY :

Slightly grease contact surfaces, threads, shaft and wheel bore and introduce the hub inside the wheel. Pre-tighten the screws and place this unit on the gearbox shaft and position according to the table section 6.4.2. Cross tighten the screws two or three times and tighten to the according torque section 9.11 TORQUES AND FIGURES.

DISASSEMBLY :

Untighten the screws on the hub and place them in the unlock holes. Tighten the screws until the two elements of the hub disassemble and withdraw the wheel hub.

Unlock holes

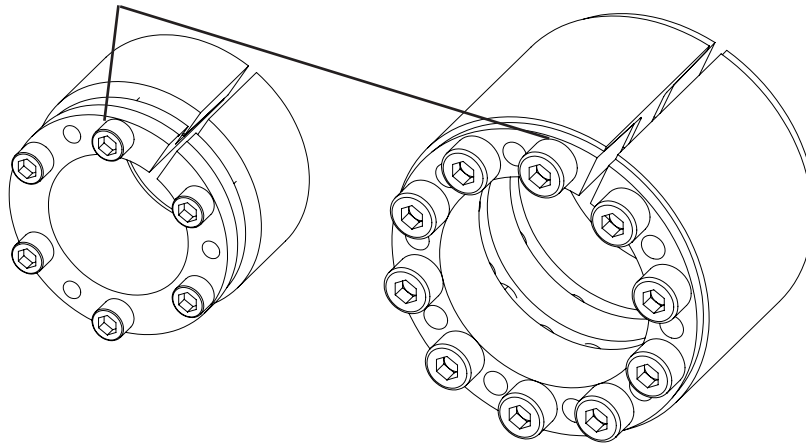

ALH05 à ALHX40
2 part expansible hub.part

ALH50 à ALH65
3 part expansible hub.part

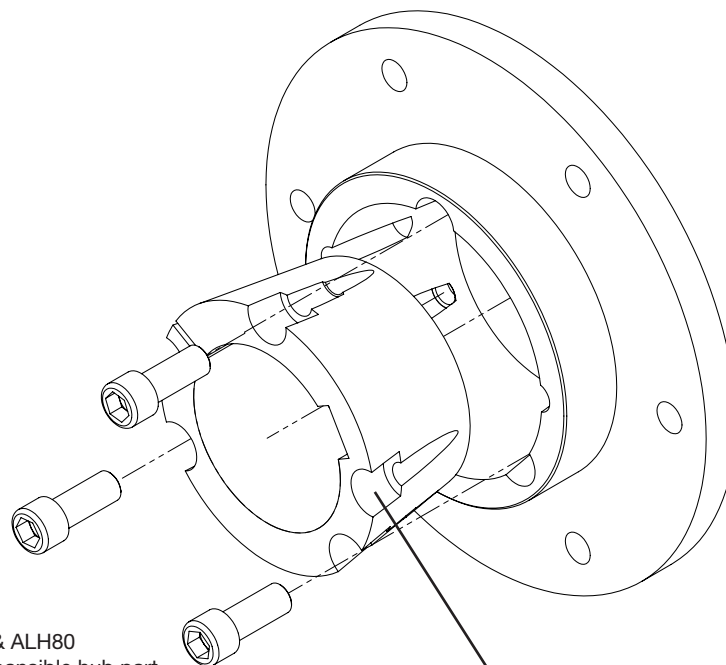

ALHX80 & ALH80
1 part expansible hub.part

Unlock holes

9.11 - TORQUES FIGURES

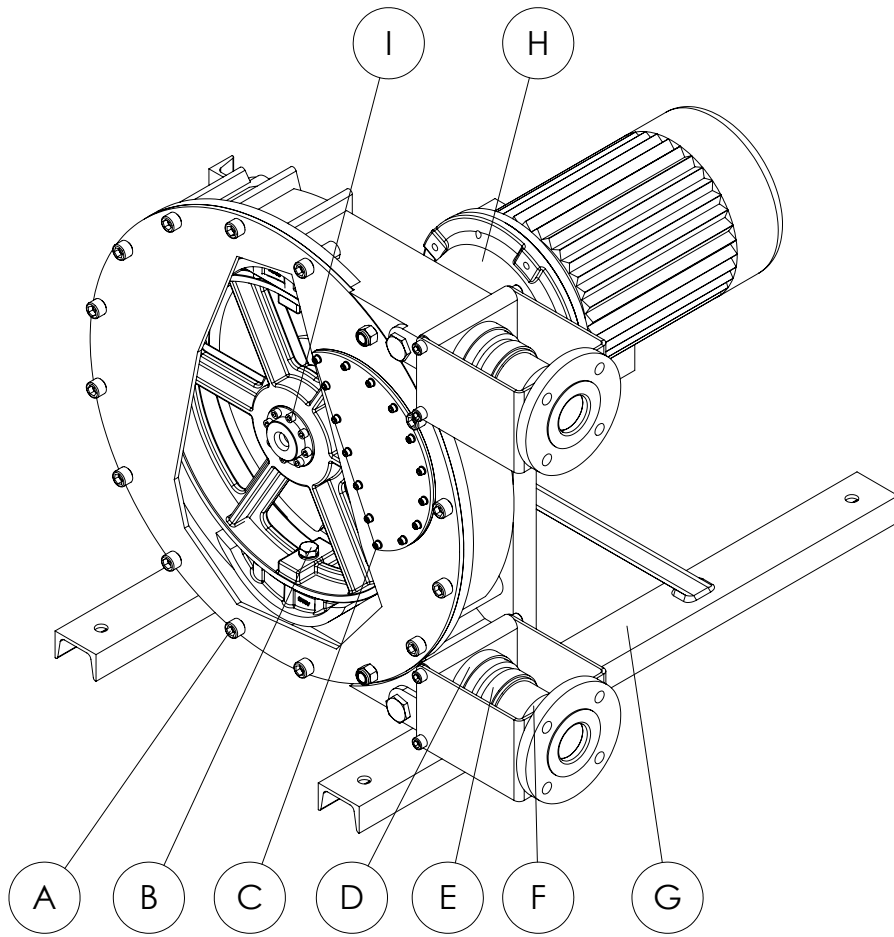

POS.	DESIGNATION	MAX TORQUES IN Nm								
		ALH 05 ALH20	ALH25	ALH32 ALH40	ALHX40	ALH50 ALH65	ALHX80	ALH80	ALH100	ALH125
A	COVER	3.3	7.8	27	27	65	65	65	127	127
B	SHOE		46	79	79	402	402	402	691	691
C	WINDOW		3.3	3.3	3.3	3.3	3.3	3.3	3.3	3.3
D	CLAMP REF7	4	4	4	4	4	4	4	4	4
E	CLAMP REF8	12	16	30	30	30	30	45	45	45
F	CLAMP REF9	12	50	50	50	50	50	50	50	50
G	FRAME	8	15	27	27	65	127	127	220	220
H	GEARBOX	34	67	116	116	116	291	291	291	291
I	HUB	12	13	13	27	35	110	110		

9.12 - WEIGHTS SERIE ALH ET ALHS

ALL DIMENSIONS IN KILOGRAMS																
PART	ALH05-10	ALH15	ALH20	ALH25	ALH32	ALH40	ALHX40	ALH50	ALH65	ALHX80	ALH80	ALH100	ALH125			
CASING	5	8	8	16	29	29	43	88	88	140	240	375	450			
WHEEL	1,2	3	3	4,3	7,7	7,7	12,9	27,5	27,5	37,3	62,3	89	173			
COVER	0,3	0,6	0,6	5	10,3	10,3	15,4	23,5	23,5	41	60	89	203			
FRAME	1,3 (X2)	1,7 (X2)	1,7 (X2)	6 (X2)	12,5 (X2)	12,5 (X2)	13,4 (X2)	15,9 (X2)	15,9 (X2)	25,5 (X2)	48 (X2)	62,5 (X2)	274			
SHOE				ALU	IRON	ALU	IRON	ALU	IRON	ALU	IRON	IRON	IRON	IRON	IRON	IRON
				0,34	0,9	0,55	1,44	0,68	1,79	0,9	2,37	3,2	3,2	3,2	3,2	3,2
HOSE	0,4	0,8	1,4	2	3	3	4	6	6	15	20	30	45			

10/ COMPLEMENTARY INSTRUCTIONS FOR ATX CERTIFIED MATERIAL

Peristaltic hose pump

Complementary instructions for ATEX certified material.

Models : Albin Pump ALH and ALHS

Pumping and operation in zone 0 is completely banned.

The pumps are planned for a use in the following gas and dust explosive atmospheres.

II 2G : zone 1 and 2

II 3G : zone 1 and 2

II 2D : zone 1 and 2

II 3D : zone 1 and 2

The following instructions must be read jointly with :

- > All ATEX regulations for the country for which the pump is destined.
- > Decrees, laws, directives, application circulars, the standards, the code of practice, and any other document concerning its place of installation.

No responsibility whatsoever is taken for the non-observance of these instructions.

The ATEX form provided by the customer which stipulates all the data concerning his process and application of the pump is the only evidence in case of dispute. The non-observance of this data will disengage the responsibility of ALBIN PUMP SAS.

This information is complementary to our general maintenance manual.

The installation of the material must be carried out by qualified and skilled personnel.

Our equipment is marked EEC with the ATEX 94/9/CE title.

Ensure compatibility between the indications being reproduced on the gauge, the present explosive atmosphere, the zone of use, ambient and surface temperatures.

Until the 30.06.2003, the equipment on the market could be equipped with accessories or (and) components certified according to the rules of CENELEC relating to the electric materials usable in explosive atmospheres of group II. From this date, the accessories or (and) component assembled equipping the motors with our pumps must have an EEC examination certificate.

Sommaire

1 - Level of pumps certification

2 - Protection of the pumping part

3 - Protection of the transmission part

4 - Particular dispositions when using a frequency inverter

5 - Dry running the pumps

6 - Replacement of parts

7 - Solvents incompatible with pumps seals

8 - Possible leakage of pumped liquid

9 - Checking lubricant level in the pump

10 - Drive of the pump

10.1 Alignment of the pump and the drive (only for the ALHS pumps)

10.2 Flexible couplings

10.3 Electric installation of the motor or the motor reducer of the pump

10.4 ATEX characteristics of the motor or the motor reducer of the pump

11 - ATEX characteristics of the pumping installation

12 - Pumping vat of retention

13 - Marking of the pump

1 - Pumps certification level

All ALBIN peristaltic pumps are certified with II 2G T4, II 3G T4 or II 2D T4 certification.

All ALBIN peristaltic pumps are certified with II 2G T4, II 3G T4 or II 2D T4 certification. The pumps are machines whose surface temperatures are very dependent on the temperature of the product that they pump. Moreover, the peristaltic pumps have “mechanical” heating due to the deformations of the hose, depending on the discharge pressure and speed of rotation of the pump. So, the level of protection II 2G T4, II 3G T4, II 3D T4 and II 2D T4 is obtained with the working limits determined at the reception of the ATEX form (see adjoined form).

Pumps ALHO5, ALHS05, ALH10, ALHS10, ALH20 and ALHS20 are limited to a maximum discharge pressure of 7.5 bars.

Pumps ALH 25 to 125 and AHS25 to ALHS125 are limited to a maximum discharge pressure of 15 bars.

Going beyond of the working limitations specified at the sale is regarded as an abnormal function of the pump. This can generate surface temperatures higher than the safe maximum surface temperatures recommended in the classification of temperature T for which the pump was certified. It is the responsibility of the operator to respect these working limits.

In order to use the pump industrially with the required safety levels, safety devices have been provided (see the chapters “Protection of the pumping part” and “Protection of the transmission part”).

2 - Protection of the pumping part

The heating of the pumping part is directly related to the functioning temperature of the hose. The lifespan of the hose, which is the heart of any peristaltic pump, is strongly dependent on the working temperature of the hose : it imposes the working limits of the ALBIN peristaltic pumps. Consequentially, the working temperature of the hose (and thus the heating of the pump) must be known and controlled, and it depends on the three following parameters :

- > Temperature of pumped product
- > Number of rotations of the pump
- > Discharge pressure

For pumps II 2G T4

Use of a PT100 temperature sensor only in a gas atmosphere.

The permanent control of the maximum surface temperature of the pump housing makes it possible to control the heating of the pump effectively.

In the event of dysfunction of the pump (excessive rotation, too high temperature of pumped product, unsuitable shimming of the shoes...), the temperature sensor will detect any passing over the critical temperature of the body and will stop the pump before the surface temperatures of the pump exceed the limit corresponding to the classification of temperature T of the pump.

The threshold of release of the temperature sensor will have to be adjusted from 0°C to 75°C more or less 5°C, with a 10°C hysteresis.

For the certified pumps II 3G T4, II 2D and II 3D :

For dust zones, D becomes IP6X

According to the specific requirements for ATEX materials group II category 3, the use of such materials in an exposable atmosphere is adapted only under normal working conditions of the known material.

Thus, the end-user must make sure that the pump is used under normal working conditions, and that the particular working limits indicated in this manual are respected.

3 - Protection of the transmission part

The reducer and the motor which motorize the pump must be used within the limits of working defined by the manufacturers of these materials. Going beyond these limits is likely to generate a risk of ignition of the atmosphere surrounding the material.

The ALBIN PUMP installations are in particular designed so that the normal working conditions of the pump do not generate an overload of the motor or the reducer.

So that the function limits of these components are not exceeded, even in case of dysfunction of the pump, the motor will have to be protected from the overcurrents, in accordance with the code of practice.

4 - Particular dispositions when using a frequency inverter

The ALBIN peristaltic pumps have variable limits of working according to the discharge pressure, number of rotations of the pump and temperature of the pumped product. These working limits are mainly imposed by the heating of the hose, on which the lifespan is strongly dependent.

Within the framework of an application required to change the speed of the pump, the three following points will have to be checked.

- > Temperature of pumped product
- > Number of rotations of the pump
- > Discharge pressure

The maximum values of use will be fixed at the determination of the pump whose copy is in the appendix.

5 - Dry running the pumps

The ALBIN peristaltic pumps can function in the absence of liquid in the pump, without causing heating of the pump higher than the classified of temperature T, in particular for the period of starting-up of the pump.

In fact, dry running the pump with blocked inlets or outlets generates too high a demand on the pump hose, and can generate high internal temperatures because of the compression and decompression of the air locked up between the pump and the blocked opening.

This type of dysfunction is not controllable by a safety device (of sensor type) because the pump is dry and the mechanical constraints generated on the pump are low. Starting up the pump must thus be done after having checked that the inlet and outlet are not blocked.

Nevertheless, dry running is not a normal function of the pump and if it doesn't directly constitute a risk of ignition, it leads to premature wear and tear of the hose. This type of function must be limited as much as possible.

6 - Replacement of parts

The parts should be replaced only by original ALBIN parts which correspond to the configuration of origin of the pump. If necessary, the characteristics of the pump are modified and the ATEX certification of the pump is not applicable any more.

With each hose replacement, the adjustment of compression of the hose must be controlled and adapted to the instructions of adjustment registered in the handbook.

The technicians who intervene on ATEX material must be ATEX trained and approved.

7 - Solvents incompatible with the pump's seals

The user must make sure that the seals and the hose with which the pump is equipped are compatible with the pumped product and the products used in the cleaning of the pump.

8 - Possible leakages of pumped liquid

The possible leakages of liquid by the pump's seals do not generate a risk of ignition as long as the explosive atmosphere surrounding the material corresponds to the type of atmosphere for which it was planned.

You have to check that in contact with the atmosphere surrounding the pump or of a material located near the pump, the pumped liquids are not likely to create an explosive atmosphere for which the material was not envisaged.

The rupture of the hose, which is a wearing part, can involve important leakage of pumped liquid. A hose detector makes it possible to detect these leakages and will stop the pump if necessary.

9 - Checking of the lubricant level in the pump

An insufficient lubricant level in the pump can generate surface temperatures higher than the recommended limit of temperature T of the pump. Stop the pump and check the lubricant level every 1000 working hours.

10 - Drive the pump

The maximum speed of rotation of the pumps must be respected (see certification of the pumps). At the start or after any modification of the pumping installation, the speed of rotation of the pump must be controlled and must be lower than the maximum speed indicated in the instructions.

10 - 1 - Alignment of the pump and the drive (only for the ALHS pumps)

To carry out the alignment and the coupling, use a perfectly straight ruler to control offsetting and thickness gauges for angular misalignment.

It is important to control alignment with each stage of the installation as indicated below in order to make sure that none of these stages generate constraints on the group or the pump :

- after fixing the pump on the foundations
- after fixing the piping
- after the pump has functioned at a normal temperature of use

IMPORTANT : one should not rely on the flexible coupling to compensate for a misalignment.

10 - 2 - Flexible coupling

Certified ATEX flexible coupling must be used. These couplings must have a level of protection equivalent or higher than that of the pumping installation.

For the instructions of maintenance of certified ATEX flexible coupling of the ALBIN pumping installations, please refer to the technical note of the coupling.

10 - 3 - Electric installation of the motor or the motor reducer of the pump

Check the agreement between the indications of the motor gauge and the supply voltage.

For the connection of the motor to the electrical supply network, follow the indications of the manual supplied with the motor. Follow the assembly diagram of wiring, make sure the wires are adapted to the power consumption and make sure the contacts are tight.

The motors must be protected by suitable circuit breakers and fuses.

Make sure the earth connections are properly made.

Dry run the pump to make sure that the connections are correct and that the direction of rotation corresponds well with the suction and the discharge of the installation.

10 - 4 - Ground connection of pump

A bonding strip lug can be seen on the frames of ALH type pumps and on the pump housing and bearing case of the ALHS type pumps.

10 - 5 - ATEX characteristics of the motor or the motor reducer of the pump

The motor or motor reducer must have ATEX characteristics adapted to recognized use (group gas IIB, class of temperature T4) and must explosion-proof.

11 - ATEX characteristics of the pumping installation

A pumping installation can be composed of materials (motor, reducer, sensors...) from which ATEX characteristics are different from those of the pump.

In this case, the group will have ATEX characteristics corresponding to characteristics ATEX of the component with the lowest level of protection.

12 - Pumping vat of retention

At a constant arrival of liquid in a vat of retention in an ATEX zone, the uninterrupted start-up can generate a classification in zone 0.

The case can only arise when the pump is used in the starting position. It is then imperative that the suction pipe always has liquid present so as not to create explosive conditions in the presence of fuel and combustible agents. Thus, the adjustment of the low point of the tank will have to be higher than the opening of the suction pipe.

That will always result in the presence of liquid and not of gas and liquid.

13 - Marking of the pump

The marking of the ALBIN PUMPS is of type :

ALBIN :

TYPE ALH or ALHS

II 2 G T4 or II 3 G T4

N° series :

Year :

The marking of the ALBIN GROUPS is of type :

ALBIN :

Group ALH or ALHS

II 2 G T4 or II 3 G T4

N° series :

Year :

In the case of a pumping group, ATEX certified materials will retain their original markings.

11 / SECURITY FORM

In compliance with Health & Safety Regulations you, the user are required to declare the substances that have been in contact with the product(s) you are returning to Albin pump S.A.S. or any of its subsidiaries or distributors. Failure to do so will cause delays in servicing the item or in issuing a response. Therefore, please complete this form to ensure that we have the information before receipt of the item(s) being returned.

A FURTHER COPY MUST BE ATTACHED TO THE OUTSIDE OF THE PACKAGING CONTAINING THE ITEM(S).

You, the user, are responsible for cleaning and decontaminating the item(s) before returning them. Please complete a separate decontamination certificate for each item returned.

• 1.0 /

Company name

Address

City

Postal code

Country

Telephone

Fax number

• 2.0 / PUMP

2.1 / Serial number

2.2 / Has the pump been used ? YES NO

If yes, please complete all the following paragraphs. If no, please complete paragraph 5 only

• 3.0 / Details of substances pumped

3.1 / Chemical Names

a)

b)

c)

3.2 / Precautions to be taken in handling these substances

a)

b)

c)

3.3 / Action to be taken in the event of human contact

a)

b)

c)

3.4 / Cleaning fluid to be used if residue of chemical is found during servicing

• 4.0 / I hereby confirm that the only substances(s) that the equipment specified has pumped or come into contact with are those named, that the information given is correct, and the carrier has been informed if the consignment is of a hazardous nature.

• 5.0 /

Signed

Name

Position

Date

12 / STATEMENT OF COMPLIANCE CE

SECTION 1.0

Description of the pump :

Producer :

ALBIN PUMP
ZAC DE FONTGRAVE
26740 MONTBOUCHER SUR JABRON
TEL : 04 75 90 92 92
FAX : 04 75 90 92 40

Type :

ALH05 - ALH10 - ALH15 - ALH20 - ALH25 - ALH32 - ALH40 - ALHX40 - ALH50 - ALH65 - ALHX80 -
ALH80 - ALH100 - ALH125

Serial N° :

Description : Volumetric pump, hose pump

SECTION 2.0

Applicable directives :

Machinery directives :

89 / 392 / EEC
89 / 655 / EEC
91 / 368 / EEC
93 / 44 / EEC

SECTION 3.0

Label :



SECTION 4.0

Statement :

We declare under our responsibility that the equipment defined in section 1.0 satisfies in all the directives of the European Community specified in section 2.0 and in the French work legislation.

Christian Söderholm



Date: 30 July 2007

SAFETY AND CONTROL MEASURES TO RESPECT IMPERATIVELY

1 - Mechanical risk

Ensure that all protections (cover, sight glass, ventilator hood, coupling protection) are in place before operating the pump. Disconnect the electricity supply before any mechanical intervention, except during a hose replacement. Hose replacement must be done with the pump cover closed.

While replacing a hose, wear protective gloves and clothes and keep hands away from the brackets, suction

and discharge flanges.

During the pump maintenance, check that the lifting points are correctly used.

The frame of the pump must be firmly fastened to the ground.

2 - Electrical risk

Ensure that the electrical installation is conforming to the standards required in the country of use especially regarding earth and thermal protection.

3 - Operational risk

Check the compatibility of the products to be pumped with:

- The peristaltic pump principle.
- The hose material.
- The lubricant.
- The inserts material.
- The shoe material.

ALBIN PUMP cannot guaranty the hose lifetime or the product loss due to a hose burst. It is the operator's responsibility to prevent pumped liquid loss with additional hose rupture detectors and or automatic shutdown valves. Check §2.4 conditions of guarantee for further information. Ensure that the pump is compatible with the required process. Ensure that the pressure applied on the suction side is compatible with the pump. The rupture of the hose and its consequences must be taken in account :

- The pump casing can be filled with the pumped product.
- If the suction line is on load, this one can empty into the pump casing and leak out of the pump.
- If the discharge line is under pressure, the pumped product may be forced back into the pump casing and leak out of the pump.

A leakage detector as well as automatic shutdown valves are recommended in order to prevent such consequences.

While draining the pump following a hose rupture, take note of the risk of pollution caused by the lubricant and by the pumped product.

The pump, being volumetric, may suffer dangerously high pressure by even partial blockage of the discharge line.

Ensure that all protections have been made regarding this aspect.

Before each use, check the direction of rotation of the pump. While placing the pump under vacuum, mount window screws using an airtight glue to avoid air leakage.



36 Hudson Rd
Sudbury MA 01776



800-225-4616
www.tisales.com

FLOMOTION SYSTEMS Inc.

165 Creekside Drive, Suite 112
Buffalo, NY 14228-2103
Tel:800-909-3569 (U.S. & Canada)
or 716-691-3941
Fax:716-691-1253
E-Mail: info@flomotionsystems.com

For more information about our worldwide locations, approvals, certifications, and local representatives, please visit www.albinpump.com. ALBIN PUMP reserves the right to incorporate our latest design and material changes without notice or obligation. Design features, materials of construction and dimensional data, as described in this bulletin, are provided for your information only and should not be relied upon unless confirmed in writing.

Certified drawings are available upon request. © 2008 ALBIN PUMP