

SUBMITTAL INFORMATION

Straight Ball Flange Meter Valves - (BF73-xxxW-NL style)

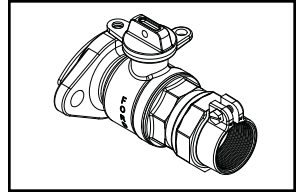

PACK JOINT FOR PVC PIPE INLET BY METER FLANGE OUTLET

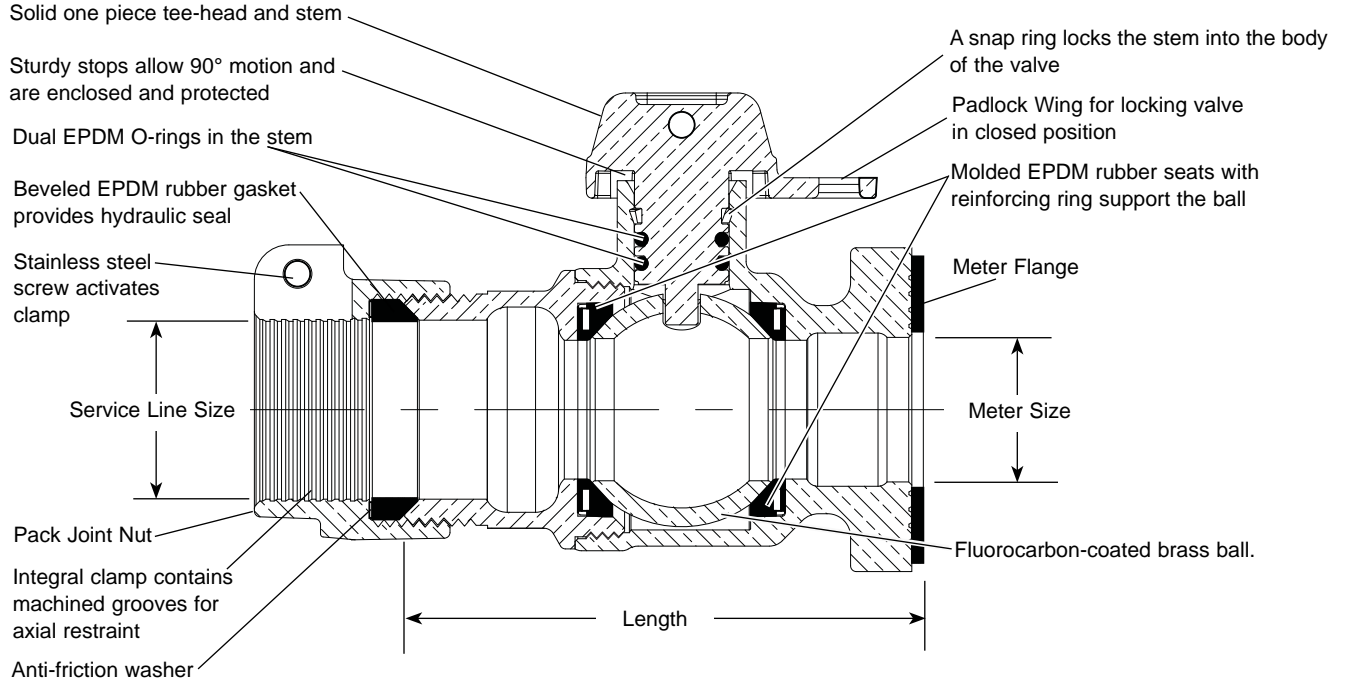

VALVE SIZE	SERVICE LINE SIZE	METER SIZE	LENGTH	APPROX. WT. LBS	PART NUMBER	✓ SUBMITTED ITEM(S)
1-1/2"	1-1/2"	1-1/2"	5-1/2"	8.3	BF73-666W-NL	
2"	2"	2"	7-3/16"	12.2	BF73-777W-NL	

Note: Ford Pack Joints for PVC are only recommended for Schedule 40 and Schedule 80 pipe.

FEATURES

- All brass that comes in contact with potable water conforms to AWWA Standard C800 (ASTM B584, UNS C89833)
- The product has the letters "NL" cast into the main body for lead-free identification
- Certified to NSF/ANSI Standard 61 and NSF/ANSI Standard 372 where applicable
- Brass components that do not come in contact with potable water conform to AWWA Standard C800 (ASTM B62 and ASTM B584, UNS C83600, 85-5-5-5)
- Valve is non-directional and is watertight with flow in either direction
- Ends are integral or secured with adhesive to prevent unintentional disassembly
- Padlock Wing for locking valve in closed position
- Hole for attaching handle is provided in the tee-head
- 300 PSI working pressure
- Furnished with flat EPDM drop-in meter gasket.
- Slotted holes are standard on 2" flanged meter valves, allowing 1-1/2" flanged meter connection.

Optional full 360° tee-head rotation. Add "R" to end of part number.

Optional Meter Support Brackets. Add "- MSB" to end of part number.

The Ford Meter Box Company considers the information in this submittal form to be correct at the time of publication. Item and option availability, including specifications, are subject to change without notice. Please verify that your product information is current.



The Ford Meter Box Company, Inc.
 P.O. Box 443, Wabash, Indiana U.S.A. 46992-0443
 Phone: 260-563-3171 / Fax: 800-826-3487
 Overseas Fax: 260-563-0167
 www.fordmeterbox.com

11/05/15

Submitted By:



36 Hudson Rd
 Sudbury MA 01776



800-225-4616
 www.tisales.com