

By-Pass & Filter Feeders

PRODUCT BROCHURE



www.neptune1.com

Neptune

FILTER FEEDER

MODEL NO.	ETC-3350RP
CAPACITY	7.5 GALLONS
MAX. WORKING PRESS.	300 P.S.I.
MAX. WORKING TEMP.	200 °F



36 Hudson Rd
Sudbury MA 01776

800-225-4616
www.tisales.com



Where Innovation Flows



VERTICAL STYLE -
DISH BOTTOM IN



VERTICAL STYLE -
DISH BOTTOM OUT

By-Pass Feeders

Neptune By-Pass Feeders are a convenient method of introducing treatment chemicals into closed circulating water systems.

Neptune By-Pass Feeders are ideal for treating hot and chilled water circulating loops used in heating and air conditioning systems, process heating and cooling, or large engine water jackets.

Neptune offers two styles of By-Pass Feeders: A vertical style with dish bottom in and a vertical style with dish bottom out.

Filters are available for system cleanup and monitoring.

A high-pressure cap rated to 300 psi (20.7 bar) is now standard.

Vertical Style - Dish Bottom Out

The DBF series features wide-mouth caps manufactured by Neptune. These caps utilize a square-section O-ring seal and will close easily by hand. Advantages of this series are demountable leg extensions and a full bottom drain. Optional Filter Bag Kit may be added.

DBFC models include a built-in support and mounting for a cartridge filter (order cartridge separately).

See page 3 for filter specifications.

Filter Bag Kits

Available for all VTF and DBF models up to 10 gallons (39.7 L). Kit includes bag, bag frame, tubing and connectors. The addition of a filter bag allows the By-Pass Feeder to function simultaneously as a side stream filter. (A clean bag is rated at approximately 30 microns.) Cannot be used with DBFC models.



FILTER FEEDER
Convenient features include Full Bottom Drain and Anchor Bolt Holes

Filter Feeders

The Neptune Filter Feeders combine chemical addition and high-capacity filtering in one piece of equipment. They are a convenient way to introduce solid or liquid chemicals into hot or cold water closed circulating systems.

- Eliminate need for separate By-Pass Feeder and filter
- Filtration can be achieved at the same time as chemical addition
- Extended neck with top inlet allows simple installation of filter bag and basket
- Filter bags are available in 50, 20, 5 and 1 micron ratings (order separately)
- Filter bags are quickly and easily replaced

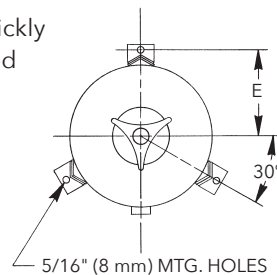

OLD STYLE CAPS
Three-lug, 1/3-turn design rated to 200 psi (13.8 bar).

NEPTUNE HIGH PRESSURE CAP
Coarse-thread, 2-1/2-turn design rated to 300 psi (20.7 bar).

Caps

All Neptune By-Pass Feeders offer a convenient, quick-opening, high-pressure closure. These closures offer better sealing with less force and eliminate the need for tools. Design binds cap tightly when under pressure making it necessary to bleed pressure from tank before removing cap. Underside of cap that contacts liquid is epoxy-coated.

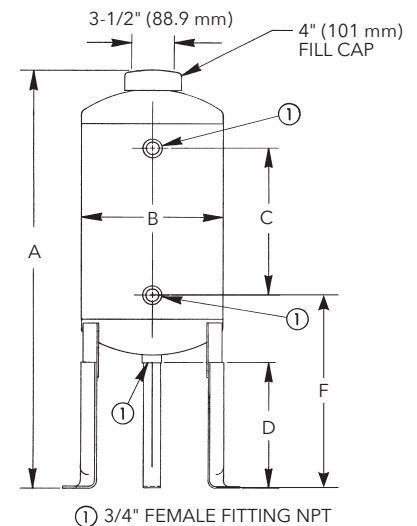

MODEL	FILTER	APPROX. CAPACITY GAL. (L)	MAX. PRESSURE PSI (BAR)*	DIMENSIONS INCHES (MM)						SHIP WEIGHT LB. (KG)
				A	B	C	D	E	F	
DBF-2HP	Optional†	2 (7.6)	300 (20.7)	31-1/4 (793.8)	6 (152.4)	12-3/4 (323.9)	8-5/8 (219.1)	4-1/8 (104.8)	13-1/4 (336.6)	23 (10)
DBFC-2	Cartridge	2 (7.6)	300 (20.7)	31-1/4 (793.8)	6 (152.4)	12-3/4 (323.9)	8-5/8 (219.1)	4-1/8 (104.8)	13-1/4 (336.6)	23 (10)
DBF-5HP	Optional†	5 (18.9)	300 (20.7)	29-3/4 (1,009.7)	10 (254.0)	10-1/2 (266.7)	8 (203.2)	6-1/8 (155.6)	13 (330.2)	38 (17)
DBFC-5	Cartridge	5 (18.9)	300 (20.7)	29-3/4 (1,009.7)	10 (254.0)	10-1/2 (266.7)	8 (203.2)	6-1/8 (155.6)	13 (330.2)	38 (17)
DBF-10HP	Optional†	10 (37.9)	300 (20.7)	45-3/4 (1,162.1)	10 (254.0)	26-1/2 (673.1)	8 (203.2)	6-1/8 (155.6)	13 (330.2)	61 (28)

*At 200°F (93°C) max. †Filter support not included with base unit. Purchase optional filter bag kit.

VTF-2HP WITH FILTER BAG KIT INSTALLED

MODEL	FOR USE ON
FBK-2	VTF-2HP, DBF-2HP
FBK-5	VTF-5HP, DBF-5HP
FBK-10	VTF-10HP, DBF-10HP



(Bag frame displayed in front of bag for clarity only.)

Vertical Style - Dish Bottom In

The VTF series is the most popular and economical by-pass feeder available from Neptune. The series uses the same wide mouth, easy-close caps described in the "Dish Bottom Out" style. Optional Filter Bag Kit may be added.

SPECIFICATIONS - ALL MODELS

- Working pressure: up to 300 psi (20.7 bar) maximum at 200°F (20°C)
- Tank shell:
 - 2-gal. (7.6 L) unit - 11-gauge steel
 - 5-gal. (18.9 L) unit - 10-gauge steel
 - 10-gal. (37.9 L) unit - 10-gauge steel
 - 12-gal. (45.4 L) unit - 10-gauge steel
- Tank heads:
 - 2-gal. (7.6 L) unit - 11-gauge steel
 - 5-gal. (18.9 L) unit - 9-gauge steel
 - 10-gal. (37.9 L) unit - 9-gauge steel
 - 12-gal. (45.4 L) unit - 9-gauge steel
- Cap: Wide-mouth cast iron with Buna-N O-ring, easy open/easy close

STANDARD MODELS

MODEL	FILTER	APPROX. CAPACITY GAL. (L)	MAX. PRESSURE PSI (BAR)*	DIMENSIONS INCHES (MM)			SHIP WEIGHT LB. (KG)
				A	B	C	
VTF-2HP	Optional†	2 (7.6)	300 (20.7)	21-1/4 (539.6)	6 (152.4)	12-3/4 (323.9)	23 (10)
VTF-5HP	Optional†	5 (18.9)	300 (20.7)	19-3/4 (501.7)	10 (254)	10-1/2 (266.7)	37 (17)
VTF-10HP	Optional†	10 (37.9)	300 (20.7)	35-3/4 (908.1)	10 (254)	26-1/2 (673.1)	60 (27)
VTF-12HP	N/A	12 (45.4)	300 (20.7)	42 (1,066.8)	10 (254)	32-3/4 (831.9)	68 (31)

*At 200°F (93°C) max. †Filter support not included with base unit. Purchase optional filter bag kit.

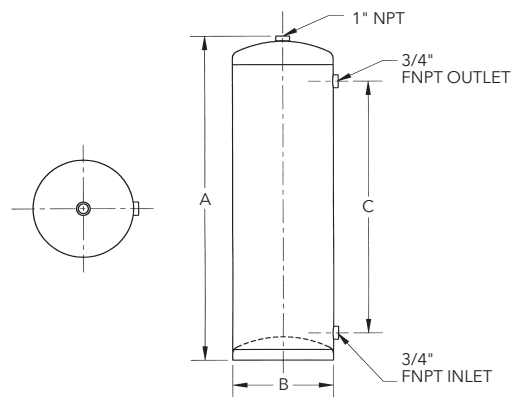
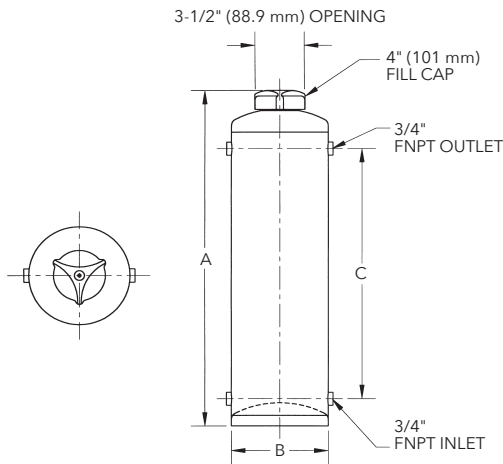
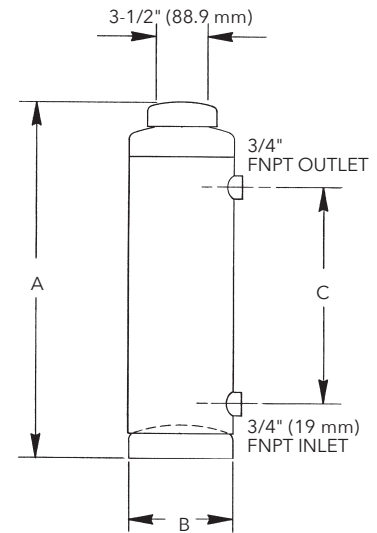

FOUR FITTING MODELS

MODEL	APPROX. CAPACITY GAL. (L)	MAX. PRESSURE PSI (BAR)*	DIMENSIONS INCHES (MM)			SHIP WEIGHT LB. (KG)
			A	B	C	
VTF-2X4HP†	2 (7.6)	300 (20.7)	21-1/4 (539.6)	6 (152.4)	12-3/4 (323.9)	23 (10)
VTF-5X4HP†	5 (18.9)	300 (20.7)	19-3/4 (501.7)	10 (254.0)	10-1/2 (266.7)	37 (21)

*At 200°F (93°C) Max. †Filter support not included with base unit. Purchase optional filter bag kit.

FEEDER BODIES

MODEL	APPROX. CAPACITY GAL. (L)	MAX. PRESSURE PSI (BAR)*	DIMENSIONS INCHES (MM)			SHIP WEIGHT LB. (KG)
			A	B	C	
VTF-2-1	2 (7.6)	300 (20.7)	20 (508)	6 (152.4)	12-3/4 (323.9)	23 (10)
VTF-5-1	5 (18.9)	300 (20.7)	18 (457.2)	10 (254.0)	12-3/4 (323.9)	37 (21)

*At 200°F (93°C) Max.

Cartridge Filter Units

DBFC models include a built-in support and mounting for a cartridge filter. Order cartridge separately.

Cartridge filter modification cannot be installed in DBF models. DBFC model must be ordered for use with cartridge filter.

PART NO.	DESCRIPTION
107290	5-MICRON PLEATED FILTER
107287	20-MICRON PLEATED FILTER

DBFC-5 WITH CARTRIDGE FILTER INSTALLED



FILTER ASSEMBLY



Filter Feeders

FEATURES AND BENEFITS

- Stainless steel dissolving basket holds and fully supports the filter bag inside (order bag separately)
- Ring-top bags feature handles for easy removal
- "DB" type feeders have a full bottom drain and bolt-on legs with anchor bolt holes
- Model FTF-5150HP features oversize 1-1/2" (38 mm) inlet and outlet connections. Can be used for system cleanup with high-volume pumps where high flow rates are desired for fast clean-up or flush-out prior to start-up

MODEL	APPROX. CAPACITY GAL. (L)	MAX. PRESSURE PSI (BAR)*	DIAM. IN. (MM)	CONN. SIZE FNPT	DIMENSIONS INCHES (MM)			
					A	B	C	D
FTF-2HP	2-1/2 (9.5)	300 (20.7)	6 (152.4)	3/4 (19)	N/A			
FTF-2DB	2 (7.6)	300 (20.7)	6 (152.4)	3/4 (19)	N/A	4-3/4 (120.7)	8-1/2 (215.9)	
FTF-5HP	7-1/2 (28.4)	300 (20.7)	10 (254.0)	3/4 (19)	N/A			
FTF-5DB	5 (18.9)	300 (20.7)	10 (254.0)	3/4 (19)	N/A	5-1/4 (133.4)	12-1/2 (317.5)	
FTF-5150HP	7-1/2 (28.4)	300 (20.7)	10 (254.0)	1-1/2 (38)	N/A			
FTF-5150DB	5 (18.9)	300 (20.7)	10 (254.0)	1-1/2 (38)	N/A	5-3/8 (135.8)	6-1/4 (156.6)	

See page 3 for filter specifications.

*At 200°F (93°C) max.

MODEL FTF-5HP



MODEL FTF-2DB

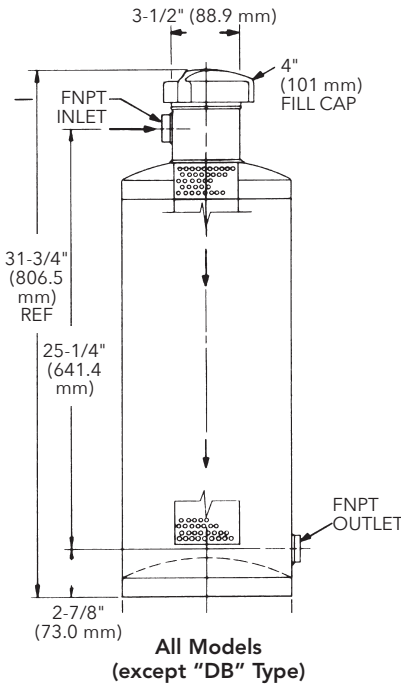
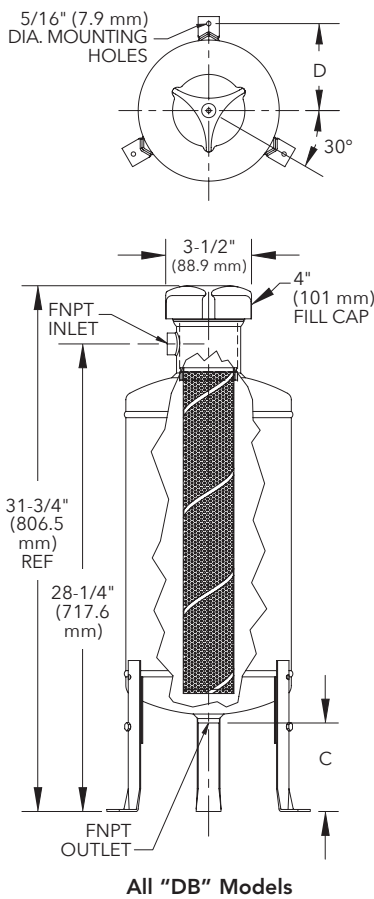

DISSOLVING CYLINDER



FILTER BAG



FILTER BAGS

PART NO.	TYPE	QUANTITY	DESCRIPTION
107026	ULTRA FINE	PKG. OF 1	1-MICRON RING-TOP BAG
106453	FINE	PKG. OF 1	5-MICRON RING-TOP BAG
107289	MEDIUM	PKG. OF 1	20-MICRON RING-TOP BAG
107231	COARSE	PKG. OF 1	50-MICRON RING-TOP BAG

All bags fit any "FTF" model.



PSG
22069 Van Buren Street
Grand Terrace, CA 92313-5651 USA
P: +1 (909) 422-1700 • F: +1 (909) 783-3440
psgdoover.com/neptune

Distributed By:



36 Hudson Rd
Sudbury MA 01776



800-225-4616
www.tisales.com

Where Innovation Flows

