



Commercial and Industrial MACH 10[®] Ultrasonic Meter
Installation and Maintenance Guide



Commercial and Industrial MACH 10[®] Ultrasonic Meter
Installation and Maintenance Guide

Copyright

This manual is an unpublished work and contains the trade secrets and confidential information of Neptune Technology Group Inc., which are not to be divulged to third parties and may not be reproduced or transmitted in whole or part, in any form or by any means, electronic or mechanical for any purpose, without the express written permission of Neptune Technology Group Inc. All rights to design or inventions disclosed herein, including the right to manufacture, are reserved to Neptune Technology Group Inc.

Neptune engages in ongoing research and development to improve and enhance its products. Therefore, Neptune reserves the right to change product or system specifications **without** notice.

Trademarks Used in This Manual

MACH 10[®] and E-CODER[®] are registered trademarks of Neptune Technology Group Inc. MACH 10[®])R900i[™], and ProRead[™] are trademarks of Neptune Technology Group Inc. Other brands or product names are the trademarks or registered trademarks of their respective holders.

FCC Notice

This device complies with Part 15 of the FCC Rules. Operation is subject to the following two conditions:

- This device may not cause harmful interference.
- This device must accept any interference received, including interference that may cause undesired operation.

Note: This equipment has been tested and found to comply with the limits for a Class B digital device, pursuant to Part 15 of the FCC Rules. These limits are designed to provide reasonable protection against harmful interference in a residential installation. This equipment generates, uses, and can radiate radio frequency energy, and if not installed and used in accordance with the instructions, may cause harmful interference to radio communications. However, there is no guarantee that interference will not occur in a particular installation. If this equipment does cause harmful interference to radio or television reception, which can be determined by turning the equipment off and on, the user is encouraged to try to correct the interference by one or more of the following measures:

- Reorient or relocate the receiving antenna.
- Increase the separation between the equipment and receiver.
- Connect the equipment to an outlet on a circuit different from that to which the receiver is connected.
- Consult the dealer or an experienced radio / TV technician for help.



Changes or modifications not expressly approved by the party responsible for compliance could void the users' authority to operate the equipment.

Professional Installation

In accordance with section 15.203 of the FCC rules and regulations, the Neptune endpoint must be professionally installed by trained meter installers. Changes or modifications not expressly approved by the party responsible for compliance void the user's authority to operate the equipment.

Industry Canada

This Class B digital apparatus meets all requirements of the Canadian Interference Causing Equipment Regulations. Operation is subject to the following two conditions:

- This device may not cause harmful interference.
- This device must accept any interference received, including interference that may cause undesired operation.

Cet appareillage numérique de la classe B répond à toutes les exigences de l'interférence canadienne causant des règlements d'équipement. L'opération est sujette aux deux conditions suivantes: (1) ce dispositif peut ne pas causer l'interférence nocive, et (2) ce dispositif doit accepter n'importe quelle interférence reçue, y compris l'interférence qui peut causer l'opération peu désirée.

Commercial and Industrial MACH 10[®]
Ultrasonic Meter Installation and Maintenance Guide
Literature No. IM MACH 10 C&I 07.2021
Part No. 13920-001

Neptune Technology Group Inc.
1600 Alabama Highway 229
Tallahassee, AL 36078
Tel: (800) 633-8754
Fax: (334) 283-7293

Copyright © 2020-2021
Neptune Technology Group Inc.
All Rights Reserved.

Chapter 1: Product Description	1
Introduction	1
Understanding Ultrasonic Technology	2
Transit-Time Technology.....	2
Summary	3
Chapter 2: Commercial and Industrial MACH 10® Specifications	5
Environmental and Performance Specifications	5
Weight and Dimension Specifications	6
Dimensions	6
Additional Specifications	7
Fluid Compatibility	8
Maincase	8
Transducers	8
Battery Requirement	8
Chapter 3: General Installation Guidelines	9
Tools and Materials	9
Safety and Preliminary Checks	10
Installation and Application Considerations	10
Water Temperature	10
Meter Installation	10
Water Flow	11
Meter Sizing and Selection	12
Chapter 4: Installing C&I MACH 10® Ultrasonic Meters	13
Installation Instructions for C&I MACH 10® Meters	13
Prior to Installation	13
Storage	13
Unpacking	13

Handling the Meter	13
Upstream and Downstream Requirements	14
Strainer	14
Elbows	15
Valves	15
Test Tee	16
Installation – Commercial and Industrial	16
Wiring the MACH 10®	17
Completing the Wiring	19
<i>Chapter 5: Activating and Reading C&I MACH 10® Ultrasonic Meters</i>	23
Activating the LCD Meter Display	23
Timeout Period	23
Meter Display	23
LCD Panel	24
How to Read the Meter	24
Alarms	24
LCD Icons	25
Consumption and Unit of Measure – Commercial and Industrial	26
Rate of Flow	27
Flow Direction	27
AMR / AMI Output	27
Endpoint Reading Resolution	27
<i>Chapter 6: Testing the Commercial and Industrial MACH 10®</i>	29
Bench Testing the Commercial and Industrial MACH 10® Meter	29
Meter Accuracy Testing Guidelines	29
Test Procedure	30
Test Data	33

Test Troubleshooting	35
<i>Chapter 7: Maintenance and Troubleshooting</i>	<i>37</i>
Maintenance	37
Unitized Measuring Element (UME) Maintenance	37
Replacement Parts	38
General Troubleshooting	38
Checklist	39
Contact Information	40
By Phone.....	40
By Email	40
<i>Appendix A: MACH 10®)R900i™</i>	<i>41</i>
Product Description	41
MACH 10®)R900i™ Programming	41
RF Protocol Error Detection	41
MACH 10®)R900i™ Specifications	42
Dimensions – Commercial and Industrial	42
Electrical Specification	44
Transmitter Specifications	44
Functional Specifications	45
<i>Appendix B: C&I MACH 10®)R900i™ Flags</i>	<i>47</i>
<i>Glossary</i>	<i>49</i>
<i>Index</i>	<i>53</i>

This page intentionally left blank.

Figure 1 – 3" Commercial and Industrial MACH 10® Ultrasonic Meter	2
Figure 2 – Cross-Section of a 3" Commercial and Industrial MACH 10®	3
Figure 3 – Unitized Measuring Element	4
Figure 4 – Commercial and Industrial Meter Dimensions – Side View	6
Figure 5 – Bleed Screw Location	11
Figure 6 – Bleed Screw Details	11
Figure 7 – Install a Strainer Upstream or Downstream	14
Figure 8 – Elbow Configuration	15
Figure 9 – Install Valves Upstream or Downstream	15
Figure 10 – Install a Test Tee	16
Figure 11 – Scotchlok™ Connector	17
Figure 12 – Seat the Connector Wires	18
Figure 13 – Crimping Tool	18
Figure 14 – Three Colored Wires Connected	19
Figure 15 – Splice Tube	20
Figure 16 – Gray Wires in Slot	20
Figure 17 – Cover in Place	21
Figure 18 – Commercial and Industrial MACH 10® Meter	23
Figure 19 – MACH 10® LCD Panel	24
Figure 20 – Turn the Bleed Screw	31
Figure 21 – Unitized Measuring Element Commercial and Industrial MACH 10® Meter	37
Figure 22 – Commercial and Industrial MACH 10®)R900i™ – Top View	42
Figure 23 – Commercial and Industrial MACH 10®)R900i™ – Front View	42
Figure 24 – Commercial and Industrial Meter Dimensions – End View	43

This page intentionally left blank.

Table 1 – Environmental Specifications	5
Table 2 – Performance Specifications	5
Table 3 – Commercial and Industrial MACH 10® Meter Weight Specifications	6
Table 4 – Commercial and Industrial MACH 10® Meter Dimensions	7
Table 5 – Additional Specifications	7
Table 6 – Recommended Tools and Materials for Meter Installation	9
Table 7 – Recommended Tools for Unitized Measuring Element Replacement	9
Table 8 – Maximum Flow Rates	12
Table 9 – Color Codes for Wires	18
Table 10 – C&I MACH 10® Icons and Displays	25
Table 11 – Consumption and Units of Measure – Commercial and Industrial	26
Table 12 – Available Units of Measure	26
Table 13 – AWWA Ultrasonic Meter Recommended Flow Rating Accuracy Testing	33
Table 14 – Neptune® C&I MACH 10® Flow Rating Accuracy Testing	34
Table 15 – Meter is Under Registering	35
Table 16 – Meter is Over Registering	36
Table 17 – Meter Stops Registering During a Test	36
Table 18 – Meter Does Not Register Water When Running a Test	36
Table 19 – Meter Does Not Register on Automated Test Bench	36
Table 20 – LCD Display Does Not Illuminate	38
Table 21 – Endpoint or LCD Display Reports Errors	38
Table 22 – MACH 10® R900i™ Meter Dimensions – Commercial and Industrial	44
Table 23 – Transmitter Specifications	44
Table 24 – Functional Specifications	45
Table 25 – Eighth Digit Resolution by Meter Size – Commercial and Industrial	47
Table 26 – MACH 10®)R900i™ Flags (digits)	47
Table 27 – MACH 10®)R900i™ Flags (minutes)	48

This page intentionally left blank.

This chapter provides a general description of the 3-inch to 12-inch Neptune® Commercial and Industrial MACH 10® Ultrasonic Meter (C&I MACH 10).

Introduction

Ultrasonic technology:

- Contains no moving parts.
- Provides long-term accuracy.
- Reduces measurement errors due to sand, suspended particles, and pressure fluctuations.



The MACH 10 solid state meter uses ultrasonic transit-time technology and solid state electronics. The C&I meter register is contained in a compact, totally encapsulated, weatherproof, and ultraviolet (UV) resistant housing for commercial and industrial applications.

The C&I MACH 10® ultrasonic water meter features solid state ultrasonic technology including a factory-calibrated, field-replaceable Unitized Measuring Element (UME) with no degradation of accuracy over time.

Combined with a corrosion-resistant, lead free, high-copper alloy maincase, the C&I MACH 10 is built to withstand any demanding service condition and deliver sustained accuracy over the life of the meter.

The C&I MACH 10 provides a Neptune E-CoderPLUS output signal to Neptune R900® and other Automatic (or automated) Meter Reading (AMR) or Advanced Metering Infrastructure (AMI) endpoints.

The meter's electronics and battery are fully potted to eliminate the intrusion of moisture, dirt, or other contaminants. It is suitable for installation in all environments including meter pits subject to continuous flooding.



Figure 1 - 3" Commercial and Industrial MACH 10[®] Ultrasonic Meter

Understanding Ultrasonic Technology

An ultrasonic water meter uses high-frequency sound waves to measure the velocity of an acoustically-conductive fluid moving through it. The velocity of the fluid is then converted to volume throughput using sophisticated algorithms and electronics.

Transit-Time Technology

The MACH 10 utilizes *transit-time* ultrasonic technology. This technology takes advantage of the principle that an acoustic signal travels faster with the flow than against the flow of the fluid. These meters use transducers that are essentially transceivers, sending, and receiving the acoustic signals at a rate of four times a second.

In the following image, the dashed lines show the acoustic path.

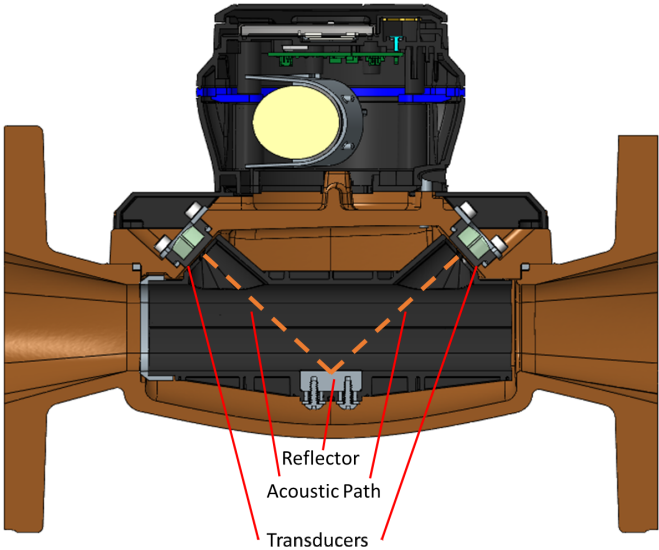

Figure 2 – Cross-Section of a 3" Commercial and Industrial MACH 10®

The difference between the downstream and upstream transit time (the time it takes for the signal to travel from one transducer set to the other) is proportional to the flow rate.

The calculated velocity of the water is then converted to volume based on the area of the measurement section.

Summary

The MACH 10 meter is a transit-time ultrasonic flow meter with wetted transducers. Designed as an alternative for mechanical meters, the MACH 10 meter utilizes traditional utility pipe connectors and lay lengths. The C&I MACH 10 battery, processor circuit, and electronic display are fully potted and housed in a replaceable UME. The UME is totally self-contained which not only minimizes field maintenance, but also eliminates the need to remove the maincase from service.

The MACH 10 meter provides an E-CoderPLUS output signal to Neptune R900[®] and other AMR / AMI endpoints. The MACH 10[®])R900i[™] contains a MACH 10 meter and an integrated R900 radio for transmitting meter reading data.



Figure 3 – Unitized Measuring Element

Chapter 2: Commercial and Industrial MACH 10[®] Specifications

This chapter provides the specifications for the C&I MACH 10[®] Ultrasonic Meter.

Environmental and Performance Specifications

This table defines environmental specifications that apply to the C&I MACH 10 meters.

Table 1 – Environmental Specifications

Specification	Description
Operating temperature	14° to 149° F (-10° to 65° C)
Storage temperature	-40° to 158° F (-40° to 70° C)
Water temperature*	33° to 122° F (+0.5° to 50° C)
Operating humidity	0 to 100% condensing

* Meets AWWA C-715 accuracy specifications for water temperatures from 33° to 122° F (+0.5 C to 50° C).

This table defines performance specifications that apply to C&I MACH 10 meters.

Table 2 – Performance Specifications

Meter Size	Extended Low Flow @ 100% Accuracy (U.S. gpm, ± 3%)	Normal Operating Range @ 100% Accuracy (U.S. gpm ± 1.5%)	Fire Services Operating Range @ 100% Accuracy (U.S. gpm ± 1.5%)
3 inch	0.50	0.75 to 500	0.75 to 420
4 inch	0.75	1.5 to 1250	1.5 to 1100
6 inch	1.0	2.0 to 2000	2.0 to 1800
8 inch	4.0	6.0 to 4000	6.0 to 4000
10 inch	6.0	10.0 to 6500	10.0 to 6500
12 inch	8.0	12.0 to 8000	12.0 to 8000

Weight and Dimension Specifications

The following tables define the weight and dimension specifications for the C&I MACH 10 meter.

**Table 3 – Commercial and Industrial MACH 10®
Meter Weight Specifications**

Meter Size	Length	Weight
3 Inch	12.00 inches	39 pounds
	17.00 inches	42 pounds
4 Inch	14.00 inches	51 pounds
	20.00 inches	57 pounds
6 Inch	18.00 inches	79 pounds
	24.00 inches	91 pounds
8 inch	20.00 inches	160 pounds
10 inch	26.00 inches	264 pounds
12 inch	19.70 inches	292 pounds

Dimensions

This section defines the dimensions of the Commercial and Industrial MACH 10 meter.

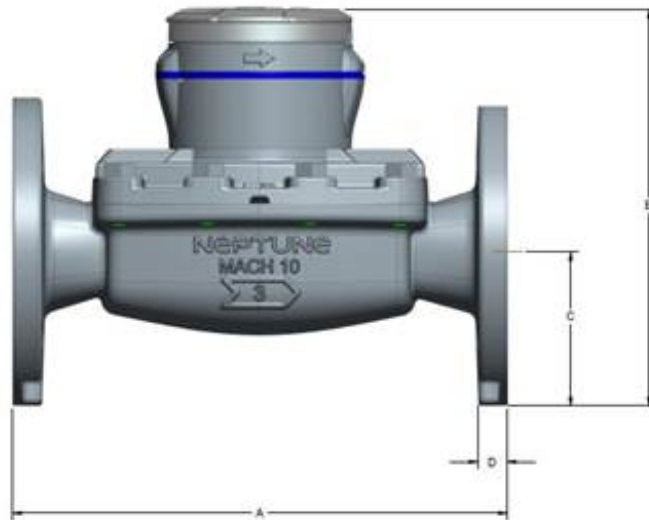

Figure 4 – Commercial and Industrial Meter Dimensions – Side View

The following table defines the dimensions for the MACH 10 meter. All measurements are in inches.

Table 4 – Commercial and Industrial MACH 10® Meter Dimensions

Meter Size	A	B	C	D
3 inch	12.00 or 17.00 inches	9.60 inches	3.75 inches	0.71 inches
4 inch	14.00 or 20.00 inches	11.00 inches	4.50 inches	0.71 inches
6 inch	18.00 or 24.00 inches	12.70 inches	5.50 inches	0.71 inches
8 inch	20.00 inches	15.71 inches	6.75 inches	1.13 inches
10 inch	26.00 inches	17.90 inches	7.96 inches	1.13 inches
12 inch	19.70 inches	20.00 inches	9.46 inches	1.13 inches

Additional Specifications

The following specifications are for the 3-inch to 12-inch C&I meters.

Table 5 – Additional Specifications

Specification	Description
Maximum operating pressure of meter housing	175 psi (12 bar).
Register type	Straight reading, permanently sealed electronic Liquid Crystal Display (LCD); digits are 0.28" (7 mm) high.
Register display	<ul style="list-style-type: none"> • Consumption (up to nine digits). • Rate of flow. • Alarms. • Unit of measure factory programmed for gallons, cubic feet, or cubic metres.
Battery	3.6 volt lithium thionyl-chloride; battery is encapsulated within the replaceable UME.

Fluid Compatibility

The MACH 10 meter is designed and calibrated for potable, combination potable and fire service, and reclaimed water across the defined temperature and velocity range.

Maincase

The C&I MACH 10 meter maincase is manufactured using lead-free bronze and is a pressure vessel that supports the UME. The UME is a replaceable assembly that contains all the elements necessary for accurate measurement and registration of water, such as the transducers, battery, electronics, and register.

Transducers

The piezoelectric transducer is the heart of the system. Although these transducers are very small, they have very high measurement dynamics.

The meter uses dual signal paths. The transducers are permanently installed and the path length and angles are fixed. Each meter is uniquely calibrated at the factory and the calibration data is permanently stored in the meter.

Battery Requirement

Solid state metering technologies require a battery to power the transducers and electronics. With the continued improvements made in battery technology, electronic metering utilizing internal batteries is practical today. The MACH 10 uses lithium thionyl-chloride battery technology.

Chapter 3: General Installation Guidelines

This chapter defines tools, materials, and general installation information for the C&I MACH 10[®].

Tools and Materials

The following tables show the recommended tools and materials you need to successfully install the C&I MACH 10 and replace the Unitized Measuring Element (UME).



The tables in this chapter do not contain complete lists of tools and materials.

Table 6 – Recommended Tools and Materials for Meter Installation

Item	Description / Recommendation	Use
Site Work Order	Documentation provided by your utility.	Receiving and recording information about the work site.
Tool Kit	Contains standard tools including: <ul style="list-style-type: none">• Screwdrivers.• Pliers.• Socket or open-face wrenches.• Replacement gaskets.	Performing various installation procedures.
Spacers (optional)	N/A	If non-compatible lay length of replacement meter.
Flashlight	N/A	Activating the LCD.
Moisture Protection Compound	Novagard [®] sealant Part No: 96018-072.	Connecting the pit antenna to the Meter Interface Unit (MIU).
Magnet	<ul style="list-style-type: none">• 6 lb force.• Part No: 12287-0001.	Activating the endpoint (if required).

Table 7 – Recommended Tools for Unitized Measuring Element Replacement

Item	Description / Recommendation	Use
Tool Kit	Contains standard tools including: <ul style="list-style-type: none">• Screwdrivers.• ¾" socket or open-face wrenches.• Replacement gaskets (provided with UME kit).	Performing various replacement procedures as outlined in the instructions. Note that a ¾" open-face wrench is required on 3" and 4" R900i UME replacements for the two bolts directly under the radio.
Flashlight	N/A	Activating the LCD.

Safety and Preliminary Checks

Observe the following safety and preliminary checks before and during each installation:

- Verify that you are at the location specified on the site work order.
- Follow all industry and company safety guidelines and procedures.
- Verify that the site is safe for you and your equipment.
- If applicable, notify the customer of your presence, and tell the customer that you need access to the water meter.
- Write the ID number of the MACH 10 meter you are about to install on the site work order. If the site work order already has a MACH 10 ID number, verify that it matches the ID number on the MACH 10 you are about to install.

Installation and Application Considerations

This section provides information to consider before installing the C&I MACH 10.

Water Temperature

The temperature range of the water is a factor in the selection of an ultrasonic meter, since the meter is calibrated to operate within a specified range. The MACH 10 meter is calibrated for water operating temperature between 33° F and 122° F (or 0.5° C and 50° C) measuring applications.

Meter Installation

Install the MACH 10 meter using horizontal or vertical piping applications. The meter features standard lay lengths for ease of retrofit of mechanical meters. A flow direction arrow is visible on the side of the meter and top of the cover to aid in installation in the proper direction.

The C&I MACH 10 does not require any straight pipe upstream or downstream from the meter to meet AWWA C715 standards. For more details, see Installing C&I MACH 10® Ultrasonic Meters beginning on page 13.

Water Flow

The MACH 10 meter is unable to measure flow when an empty pipe condition is detected. An empty pipe is defined as a condition when the ultrasonic sensors are not fully wetted. In this situation, the meter displays an Empty Pipe icon () on the register LCD and no measurement occurs.

Should this occur, purge all air from the pipes at the time of test or installation. Loosen the meter bleed screw (see the figures below) located on top of the C&I meter maincase then running as high a flow rate as reasonably possible through the meter. Turn the screw until you can feel water pushing it up and out from the meter maincase. The screw is captured and will not eject from the meter. If you have trouble purging the air, increase the exit pressure and flow rate through the meter. After the LCD shows the expected amount of water being registered, fully re-tighten the meter bleed screw.

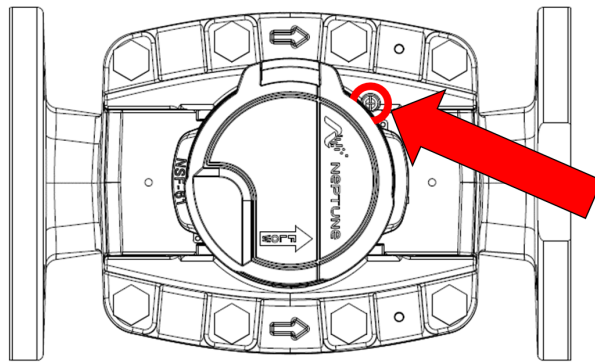

Figure 5 – Bleed Screw Location

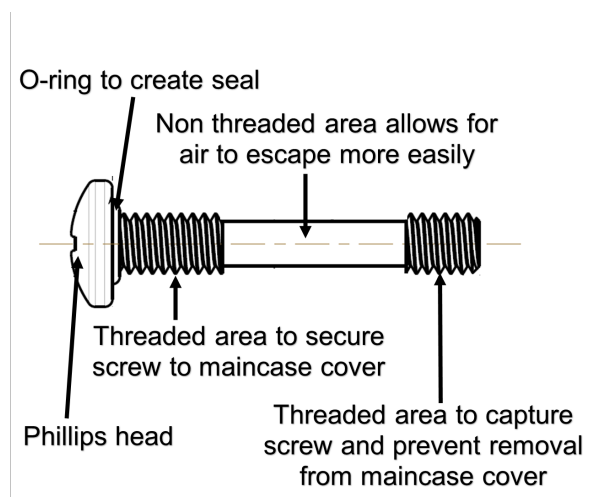

Figure 6 – Bleed Screw Details

Meter Sizing and Selection

Traditional meter sizing methods apply to both electronic meters and mechanical meters. That is, the maximum flow and maximum continuous flow rate requirements should be considered when selecting a meter. Mechanical meters allow a temporary flow at a rate higher than the maximum continuous flow. However, since electronic meters have no moving parts, these two specifications are identical; the maximum flow rate is also the maximum continuous flow rate.

The following table lists the maximum flow rates for the C&I MACH 10 meter.

Table 8 – Maximum Flow Rates

Meter Size	Safe Maximum Operating Capacity
3 inch	500 U.S. gpm
4 inch	1200 U.S. gpm
6 inch	2000 U.S. gpm
8 inch	4000 U.S. gpm
10 inch	6500 U.S. gpm
12 inch	8000 U.S. gpm

Chapter 4: Installing C&I MACH 10[®] Ultrasonic Meters

All MACH 10[®] ultrasonic meters are delivered activated and ready to be installed. When the meter lid is opened, the meter shows the empty pipe icon and the latest volume on the LCD. The empty pipe icon clears immediately after the meter is installed and the meter measuring pipe is full.

Installation Instructions for C&I MACH 10[®] Meters

This section defines the step-by-step instructions for installing the C&I MACH 10 meter.

Prior to Installation

This section defines the processes to perform before you install the meter.

Storage

Upon receipt, inspect the shipping containers for damage and inspect the contents of any damaged cartons prior to storage. After completing the inspection, store the cartons in a clean, dry environment. See Table 1 on page 5.

Unpacking

After unpacking the meter, inspect it for damage. If the meter appears to be damaged, notify your Neptune territory manager or distributor. If a meter requires return shipment, use the original cardboard box and packing material.

Handling the Meter



The C&I MACH 10 4-inch to 12-inch sizes are fitted with lift brackets to assist with handling and installation of the meters. It is recommended that you use both brackets when handling the meter with lift hooks or straps. Be sure to use only hooks or straps with appropriate weight capacity to lift the meter.

DO NOT:

- Lift the meter by the electronic housing unit.
- Use bolt holes for grip when carrying the meter.
- Position the meter on its electronic housing unit.

Upstream and Downstream Requirements

The C&I MACH 10 does not require any straight pipe upstream or downstream from the meter to meet AWWA C715 standards. Neptune's flow ranges and accuracy standards exceed those of AWWA, so in order to meet our more stringent standards some configurations may require minimum amounts of straight pipe. Any configuration of a meter with 5 diameters of straight pipe upstream meets Neptune accuracy standards.

Strainer

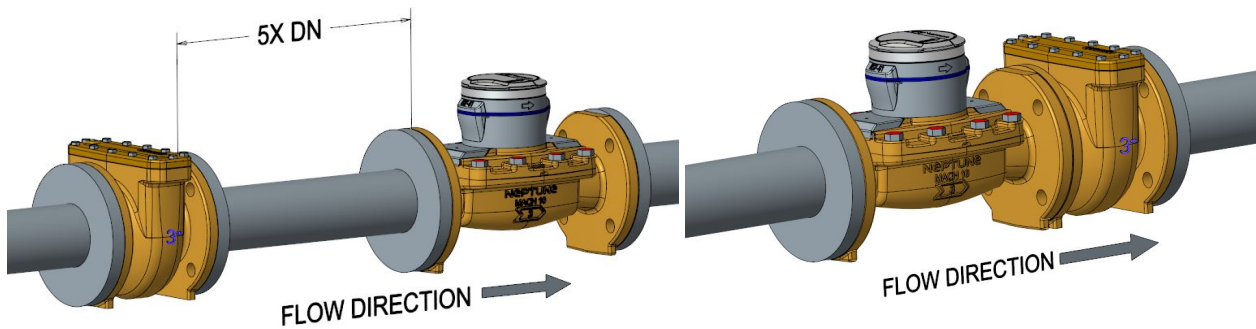

Figure 7 – Install a Strainer Upstream or Downstream

The meter does not require the use of a strainer. If you want a strainer, you can install it immediately downstream or 5 diameters upstream from the meter. During meter replacement, if a strainer is already directly installed upstream, the C&I MACH 10 meets all AWWA C715 accuracy standards for static meters. To attain the meter's highest accuracy capabilities, consider moving the strainer downstream.

Elbows

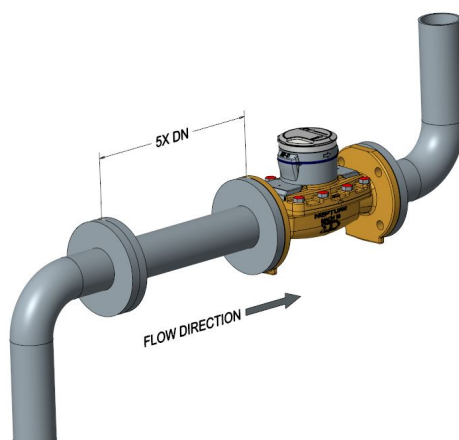

Figure 8 – Elbow Configuration

You can install elbows (90°) 5 pipe diameters upstream and directly downstream from the meter.

Valves

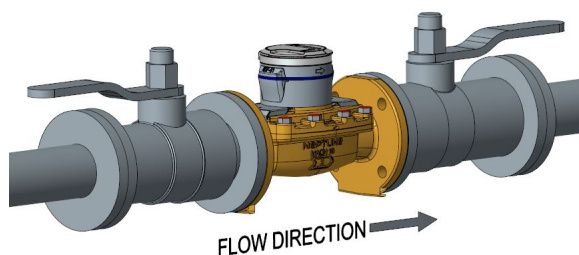

Figure 9 – Install Valves Upstream or Downstream

You can install fully open gate valves or ball valves immediately upstream or downstream of the meter. Install fully open isolation valves or butterfly valves at least 5 pipe diameters upstream or immediately downstream. If you need control valves, check valves, or backflow preventers, install them downstream to avoid cavitation. Do not install the meter on a pump suction side.

Test Tee

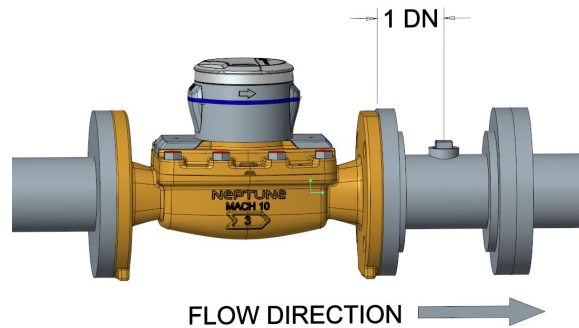

Figure 10 – Install a Test Tee

If you want a test tee, install it so that the test port is facing straight up, aligned with the meter's register. The center of the test port must be a minimum of 1 pipe diameter from the outlet flange of the meter. Two-inch test ports are recommended.

Installation – Commercial and Industrial

Following are the steps to install the C&I MACH 10 meter.



Although lighter than traditional mechanical meters, take care when moving and lifting the C&I MACH 10 meters. Lift brackets are provided on meter sizes 4-inch to 12-inch to aid in lifting the meter. Use proper company and government safety guidelines when lifting.

1. Flush the service line prior to meter installation in order to remove debris and air in the line.
2. If required by company practices, place an electrical grounding strap on the service line, connecting the inlet and outlet service lines on either side of the meter setting.
3. If you are installing the meter in a vault or enclosed area, be sure to follow all utility and industry confined-spaces safety guidelines.
4. Be sure that no debris enters the meter during installation.
5. Place the coupling gaskets, and set the meter in the line.
6. Install the mounting bolts and turn the coupling or flange nuts by hand, then use a wrench to tighten sufficiently to prevent leakage.
7. Slowly open the inlet-side valve to pressurize the meter while the outlet-side gate valve is closed.
8. Slowly open the outlet-side gate valve until the downstream line is pressurized.

9. Turn the bleed screw until you can feel water pushing it up and out from the meter maincase. The screw is captured and will not eject from the meter. For bleed screw location and details, see Figure 5 in Chapter 3.
10. Allow water to flow from the screw location during the entire purge process, (in practice, some air may still be escaping when you see water—leaving the bleed screw open helps guarantee a good purge).
11. Check to see if the meter is operating correctly while the valve is open, then fully re-tighten the meter bleed screw once the LCD shows the expected amount of water being registered. When purging the meter at 50% of its max flow with the bleed screw open, it takes 30 seconds for all trapped air to exit the meter. If you have trouble purging the air, increase the exit pressure and flow rate through the meter and continue to purge a bit longer.
12. Turn OFF the downstream valve and check the meter installation for leaks.



The C&I MACH 10 may take longer to completely remove air from the meter, particularly when flow rates are less than 50% of the maximum flow rate of the meter. If the flow rate displays 0.0 at any point after installation, it could be air is present in the meter which requires further purging.

Wiring the MACH 10®

The following table defines the steps to wire the MACH 10 meter to an endpoint while you are in the field.



If the meter is not a C&I MACH 10 prewired and potted to an endpoint, complete the following steps to wire the meter.

1. Hold the Scotchlok™ between the index finger and thumb with the red cap facing down.

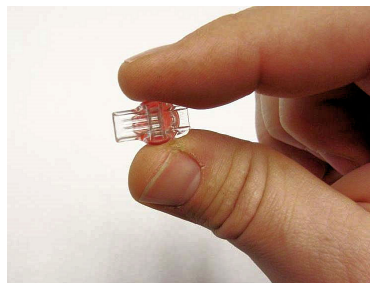

Figure 11 – Scotchlok™ Connector

2. Take one non-stripped black wire from the pigtail and one from the receptacle / endpoint.

3. Insert the wires into the Scotchlok connector.
4. Insert the insulated color wires directly into the Scotchlok connector until fully seated.

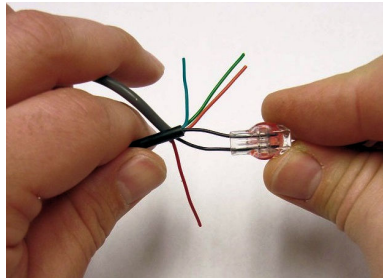

Figure 12 – Seat the Connector Wires



Do not strip the colored insulation from the wires, or strip and twist the bare wires before inserting them into the connector. Insert the insulated colored wires directly into the Scotchlok connector.

5. Place the connector red cap side down between the jaws of the UR crimping tool.

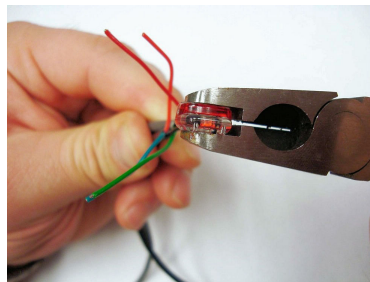

Figure 13 – Crimping Tool

6. Check to ensure the wires are still fully seated in the connector before crimping the connector.
7. Squeeze the connector firmly with the proper crimping tool until you hear a pop and the gel leaks out the end of the connector.
8. Repeat steps 1 through 5 for each color wire.

The following table provides the wiring color schemes for wiring the C&I MACH 10 to various endpoint providers.

Table 9 – Color Codes for Wires

MIU Wire Color / MACH 10® Wire Color	MIU Type
Black/B Green/G Red/R	R900®

Table 9 – Color Codes for Wires (continued)

MIU Wire Color / MACH 10 [®] Wire Color	MIU Type
Black/G Green/R Red/B	Sensus
Black/B White/G Red/R	Itron
Black/G White/R Red/B	Aclara
Black/G Green/B Red/R	Elster [®]
Black/G Green/R Red/B	Badger

Completing the Wiring

Follow these steps to wire the C&I MACH 10.

1. After you connect all three color wires, read the encoder register to ensure proper connections and the receptacle / endpoint is functioning properly.

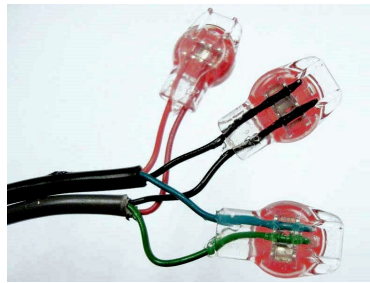

Figure 14 – Three Colored Wires Connected

2. Take all three connected Scotchloks and push them into the splice tube until fully enclosed by the silicone grease.



Figure 15 – Splice Tube

3. Separate each gray wire and place them into the slots on each side.



Figure 16 – Gray Wires in Slot

4. Snap the cover closed to finish the installation.



Figure 17 – Cover in Place

This page intentionally left blank.

Chapter 5: Activating and Reading C&I MACH 10[®] Ultrasonic Meters

This chapter explains the operations of the C&I MACH 10[®] ultrasonic meter.

Activating the LCD Meter Display

The light sensor is located in the center of the faceplate of the C&I MACH 10, and it activates the power for the Liquid Crystal Display (LCD) panel.



Figure 18 – Commercial and Industrial MACH 10[®] Meter

Timeout Period

Typically, the display is OFF. The meter includes a light sensor used to activate the LCD when you open the meter lid. You cannot reactivate a timed out LCD just by shining a light on the light sensor. To reset the LCD, close and re-open the lid.

Meter Display

The C&I MACH 10 ultrasonic meters use a nine-digit LCD to show consumption, flow rate, and alarm information.

LCD Panel

Following is an example of the C&I MACH 10 LCD panel. The table on the following page provides a description of each icon.

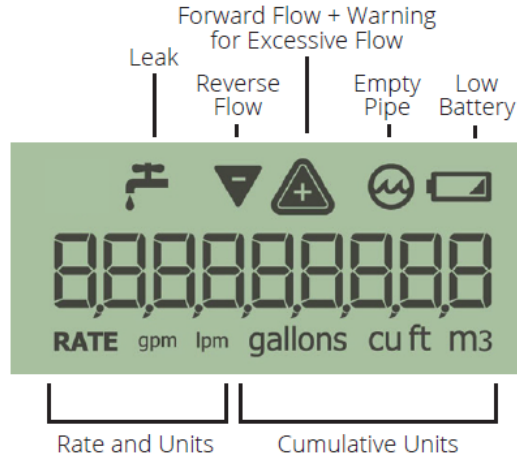

Figure 19 – MACH 10® LCD Panel



The LCD can display commas or decimals, depending on the configuration of each register to show digits in the tens position, ones position, tenths position, and so forth. For example, some registers display 1,234,567.89. Others display 123,456.789, 12,345,678.9, or 1,234,567,89 depending on the need of the meter/register combination.

How to Read the Meter

It is important to become familiar with the information available from the meter. The icons and displays provide helpful information.





Alarms

Indicators and alarms appear in the displays as symbols that illuminate when the condition is active, and disappear when the alarm condition is eliminated.

LCD Icons

The following table defines the C&I MACH 10 LCD icons and the status they indicate.

Table 10 – C&I MACH 10® Icons and Displays

Icon	Description	Status	Explanation
Leak 	Icon used to indicate a leak. Leak status is determined by keeping track of the number of 15-minute intervals where the volume consumption exceeds V_{min} in the previous 24-hour period. V_{min} is factory programmed depending on meter size. It is defined as a change of the ninth digit on the LCD.	OFF	Number of 15-minute intervals where flow was registered < 50.
		Flashing	$50 \leq$ Number of 15-minute intervals where flow was registered < 95.
		Continuous ON	Number of 15-minute intervals where flow was registered \geq 95.
Reverse and forward flow 	Icons used to indicate the reverse and forward direction of flow.	OFF	No flow is detected.
		ON	The meter has detected flow. If the icon is on but there is no accumulation, the flow rate is either well below the rated extended low flow, or well above the rated max flow of the meter.
High flow warning 	Icon used to indicate excessive flow which can be a burst pipe.	OFF	Rate of flow < Maximum defined by normal flow range specifications.
		ON	Rate of flow exceeds normal operating flow limits.
Empty pipe 	Icon used to indicate if the pipe is empty or there is excessive air in the line. If this occurs, there is no receive signal in the expected time window.	OFF	Typically OFF. Meter is operating normally.
		ON	Turned ON if no receive signal is seen for 1 minute.
Battery status 	Icon used to indicate time and voltage of remaining battery life.	OFF	> One year of battery life remaining. Time since first power ON < 9 years.
		Continuous ON	< One year of battery life remaining or time since first power ON > 9.5 years.
		Continuous FLASHING	Low battery or time since first power ON > 10 years.

Consumption and Unit of Measure – Commercial and Industrial

The consumption display contains all nine digits, including leading zeros and a decimal point. The value displayed is the sum of the forward flow minus the reverse flow.

The unit of measure and resolution are factory programmed and options include gallons, cubic feet, and cubic metres.

Table 11 – Consumption and Units of Measure – Commercial and Industrial

Meter Size	Volume Resolution				Capacity			
	Gallons	Cubic Feet	Cubic Metres	Imperial Gallons	Gallons	Cubic Feet	Cubic Metres	Imperial Gallons
3"	0.10	0.01	0.001	0.1	100,000,000	10,000,000	1,000,000	100,000,000
4"	0.10	0.01	0.001	0.1	100,000,000	10,000,000	1,000,000	100,000,000
6"	1.00	0.10	0.01	1	1,000,000,000	100,000,000	10,000,000	1,000,000,000
8"	1.00	0.10	0.01	1	1,000,000,000	100,000,000	10,000,000	1,000,000,000
10"	1.00	0.10	0.01	1	1,000,000,000	100,000,000	10,000,000	1,000,000,000
12"	1.00	0.10	0.01	1	1,000,000,000	100,000,000	10,000,000	1,000,000,000

Table 12 – Available Units of Measure

Consumption	Rate
Gallons	GPM
Cubic Feet	GPM
Cubic Meters	LPM
Cubic Metres (International)	LPM
Imperial Gallons	GPM
Acre-Feet*	GPM
Litres*	LPM
Kilolitres*	LPM

*Unit cannot be displayed on LCD

Rate of Flow

The rate of flow is factory programmed for either gallons per minute or litres per minute. The LCD displays both the unit of measure and rate of flow. The rate of flow display also serves as the flow finder indicator. The rate of flow display is shown without leading zeros. When rate of flow is displayed, it is updated every two seconds.

Flow Direction

An arrow on the electronic register housing shows the direction of flow. Current flow direction can be viewed on the LCD panel.

The direction of flow arrows on the LCD are activated when the meter detects any amount of flow. If the volume of the flow is below a predetermined measurement threshold in a given time period, the meter does not accumulate flow.

AMR / AMI Output

The Neptune MACH 10 Ultrasonic Meter is a compact design where the electronic register is fully potted and permanently sealed to the meter maincase. The meter provides high resolution E-CoderPLUS protocol. It communicates status indicators to the Neptune R900 RF endpoints as part of the extended encoder / meter reading message. The meter also provides ProRead™ protocol for third-party endpoints that are not capable of reading E-CODER® eight digit or E-CoderPLUS protocol.

Endpoint Reading Resolution

The reading resolution sent to the reading software is dependent on the endpoint to which the encoder is connected. Readings reported from the endpoints are the left-most significant digits for the encoding reading.

This page intentionally left blank.

Bench Testing the Commercial and Industrial MACH 10[®] Meter

The Neptune[®] C&I MACH 10[®] Ultrasonic Meter is designed to be bench tested as a traditional mechanical meter. However, there are certain best practices you should adhere to when testing the C&I MACH 10 meter. The following sections provide a summary.

Meter Accuracy Testing Guidelines

Following are guidelines for testing meter accuracy:

- Conduct meter accuracy tests at a stable flow rate, and keep the variation in flow rates to a minimum during the test.
- Minimize the time it takes to start and stop the test flow rate. Starting the flow should be quicker than stopping the flow to prevent water hammer during the valve closing.
- MACH 10 meters have remarkable low-flow sensitivity. Conducting meter accuracy tests at low-flow rates on a test bench designed to test large meters is challenging, so take care to ensure reliable and consistent results.
- Regularly inspect the test bench to ensure there are no leaks or leaking valves downstream of the meter. Any slight diversion of water away for the tank makes it appear that the meters are over-registering.
- If you test over a range of flow rates, start at the highest flow rate and end with the lowest. This helps ensure that all air is purged before reaching the more critical low flow tests.
- AWWA C-715 specifies visual reading capacity requirements, which dictates the value of the most significant digit. The MACH 10 has a nine-digit LCD display that together with the AWWA capacity requirement determines the resolution of the least-significant digit. Consequently, to ensure that reading errors are acceptably low, run sufficient volumes of water during low-flow testing. Refer to "Test Data " on page 33 for Neptune's recommended test volumes.
- To achieve necessary tank volume precision, low-flow testing should use the smallest practicable tank.
- Best practice is to test three times at each flow rate and average the three results to report the meter accuracy at that flow.

- If you use scales to record the weight of water from a test, be sure to check the scales at regular intervals. Converting from weight to volume is necessary and requires a density value. While this is somewhat dependent upon water temperature, a density of 8.34 pounds per gallon is generally used. Therefore, determine the test volume using the following equation when testing in U.S. gallons:

$$Volume [gal] = \frac{Weight [lbs]}{8.34 \left[\frac{lbs}{gal} \right]}$$

Use the following equation to compute test volume in cubic feet:

$$Volume [cu. ft] = \frac{Weight [lbs]}{62.38 \left[\frac{lbs}{cu. ft} \right]}$$

Test Procedure

You can test the C&I MACH 10 in the same way that a typical mechanical meter is tested. Below are some testing best practices to help you get the most out of your test:

1. Place and secure meter in test bench.



Allow a minimum distance of 5 pipe diameters between the bench's inlet and the meter. If you are testing multiple meters, allow a minimum distance of 5 pipe diameters between subsequent meters.

2. Close the outlet valves and slowly open the bench fill valve to its fully open position.
3. Open the bleed screw located near the register with a Phillips head screwdriver.



Turn the screw until you can feel water pushing it up and out from the meter maincase. The screw is captured and will not eject from the meter. Do this for each meter you test.

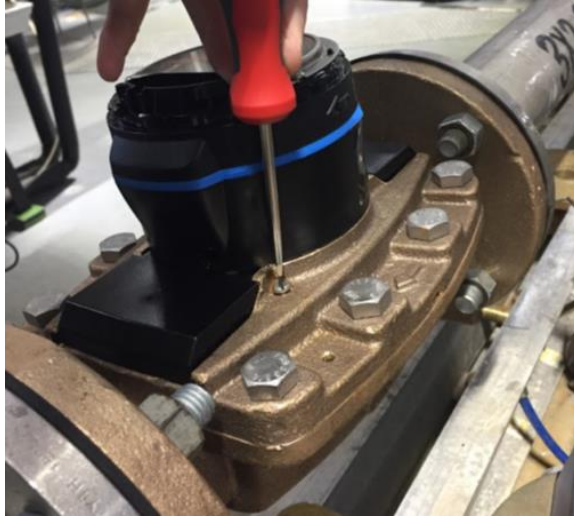

Figure 20 – Turn the Bleed Screw

4. Open the tank discharge valves.
5. Slowly open test bench outlet valves until the meter reaches 50% of its max flow.
6. Adjust the input pump's speed (output percentage) or use the test bench outlet valves to throttle the flow until the pressure at the exit of the meter is at least 30 psig.



If there is not at least 30 psi at the exit of the last meter being tested, your high (full) flow test results may not be representative of the actual accuracy of the meter.

7. When the meter is at 50% of max flow and there is at least 30 psig of back pressure on the meter, run water through the meter for at least 30 seconds to purge air out of the meter.



If there is a "PURGE" setting pre-programmed into your bench's software, Neptune recommends first performing the above 50% flow purge AND THEN running the pre-programmed "PURGE" at least five times. This ensures all pumps and lines used during testing are cleared of air. If there is not at least 30 psi at the exit of the last meter tested, your high (full) flow test results may not represent the actual accuracy of the meter.

8. After each meter is purged of air, tighten the bleed screw until you see no water exiting the meter.
9. Adjust the outlet valves to set the desired flow rate for testing. Start with high (full) flow rate (see Appendix: Table 1), then test intermediate flow rate (see Chapter 6 on page 29), and finish with low flow rate (Chapter 6 on page 29).



If you are using pre-programmed flow tests and do not have access to either the C&I MACH 10 test profile or AWWA C-715 Ultrasonic test profile, use the AWWA C-701 Turbine meter test profile.

10. After you set the flow and pressurize the flow using the test bench outlet valve, shut off the flow using the test bench outlet valve. Verify that no leaks are present. Leaks can skew results.



If possible, use a separate valve at the test outlet to start / stop flow, so the meters starts and stops the test at line pressure. If there is not at least 30 psi at the exit of the last meter tested, your high (full) flow test results may not represent the actual accuracy of the meter.

11. Check the tank to ensure the valves are closed and the tank is either empty or the weight has been tared.



If you tare the tank, ensure there is enough empty tank volume left to perform the test.

12. Record the initial register indication.
13. Open the start / stop test bench outlet valve to begin the test.



Timing the test helps to determine the average flow rate over the test. This helps to highlight if any gross flow rate fluctuations happened during the test.

14. When the test reaches the desired volume, close the outlet start / stop valve to end the test.



Close the valve at a steady rate, slowly enough so there is no water hammer effect. This has a detrimental affect to the system and meter accuracy. Do not "bump" the test to reach a certain volume / weight. This may affect the test.

15. Record the final register indication.
16. Record the tank volume / weight.
17. Calculate the accuracy of the meters.

$$Accuracy (\%) = \frac{V_{meter}}{V_{tank}} * 100$$

18. Repeat steps 9 – 17 for additional flow rates.
19. Relieve water pressure from the bench before removing the meters.

Test Data

AWWA recommendations come directly from the AWWA Manual M6. Neptune recommended intermediate flow values are 10% of the full flow. All other Neptune values come directly from Neptune literature.

Test Time was calculated based on the Gallons Test Volume and vary if cu. ft. or m3 Test Volumes are used.

Table 13 – AWWA Ultrasonic Meter Recommended Flow Rating Accuracy Testing

Size (in)	Flow	Reading Resolution			Test Volume					Test Time*
		Gallons	Cu. Ft.	m3	Rate (gpm)	Gal.	Cu. Ft.	m3	Accuracy (%)	Gallons (Min)
3	Full	0.1	0.01	0.001	200	500	50	–	100 +/- 1.5	2.5
	Intermediate	0.1	0.01	0.001	15	100	10	–	100 +/- 1.5	6.7
	Low	0.1	0.01	0.001	2.5	100	10	–	100 +/- 5.0	40
4	Full	0.1	0.01	0.001	400	1000	100	–	100 +/- 1.5	2.5
	Intermediate	0.1	0.01	0.001	20	500	50	–	100 +/- 1.5	25
	Low	0.1	0.01	0.001	3.5	300	40	–	100 +/- 5.0	85.7
6	Full	1	0.1	0.01	800	2000	200	–	100 +/- 1.5	2.5
	Intermediate	1	0.1	0.01	40	1000	100	–	100 +/- 1.5	25
	Low	1	0.1	0.01	9	300	30	–	100 +/- 5.0	33.3
8	Full	1	0.1	0.01	1000	5000	500	–	100 +/- 1.5	5
	Intermediate	1	0.1	0.01	80	3000	400	–	100 +/- 1.5	37.5
	Low	1	0.1	0.01	18	2000	300	–	100 +/- 5.0	111.1
10	Full	1	0.1	0.01	3000	7000	1000	–	100 +/- 1.5	2.3
	Intermediate	1	0.1	0.01	400	5000	500	–	100 +/- 1.5	12.5
	Low	1	0.1	0.01	50	3000	400	–	100 +/- 5.0	60

Table 13 – AWWA Ultrasonic Meter Recommended Flow Rating Accuracy Testing (continued)

Size (in)	Flow	Reading Resolution			Test Volume					Test Time*
		Gallons	Cu. Ft.	m3	Rate (gpm)	Gal.	Cu. Ft.	m3	Accuracy (%)	Gallons (Min)
12	Full	1	0.1	0.01	4000	10000	1000	–	100 +/- 1.5	2.5
	Intermediate	1	0.1	0.01	400	5000	500	–	100 +/- 1.5	12.5
	Low	1	0.1	0.01	65	3000	400	–	100 +/- 5.0	46.2

* Test times are calculated based on test volume in Gallons.

Table 14 – Neptune® C&I MACH 10® Flow Rating Accuracy Testing

Size (in)	Flow	Reading Resolution			Test Volume					Test Time*
		Gallons	Cu. Ft.	m3	Rate (gpm)	Gal.	Cu. Ft.	m3	Accuracy (%)	Gallons (Min)
3	Full	0.1	0.01	0.001	500	1500	150	5	100 +/- 1.5	3
	Intermediate	0.1	0.01	0.001	50	500	50	1.5	100 +/- 1.5	10
	Low	0.1	0.01	0.001	0.75	50	5	0.5	100 +/- 1.5	66.7
4	Full	0.1	0.01	0.001	1250	1500	150	5	100 +/- 1.5	1.2
	Intermediate	0.1	0.01	0.001	125	1000	100	2.5	100 +/- 1.5	8
	Low	0.1	0.01	0.001	1.5	50	5	0.5	100 +/- 1.5	33.3
6	Full	1	0.1	0.01	2000	2000	200	7.5	100 +/- 1.5	1
	Intermediate	1	0.1	0.01	200	1500	150	5	100 +/- 1.5	7.5
	Low	1	0.1	0.01	2	500	50	5	100 +/- 1.5	250
8	Full	1	0.1	0.01	4000	5000	500	20	100 +/- 1.5	1.3
	Intermediate	1	0.1	0.01	400	1500	150	15	100 +/- 1.5	3.8
	Low	1	0.1	0.01	6	1500	150	2.5	100 +/- 1.5	250
10	Full	1	0.1	0.01	6500	5000	500	15	100 +/- 1.5	0.8
	Intermediate	1	0.1	0.01	650	2000	200	20	100 +/- 1.5	3.1
	Low	1	0.1	0.01	10	1500	150	12	100 +/- 1.5	150

Table 14 – Neptune® C&I MACH 10® Flow Rating Accuracy Testing (continued)

Size (in)	Flow	Reading Resolution			Test Volume					Test Time*
		Gallons	Cu. Ft.	m3	Rate (gpm)	Gal.	Cu. Ft.	m3	Accuracy (%)	Gallons (Min)
12	Full	1	0.1	0.01	8000	5000	500	15	100 +/- 1.5	0.6
	Intermediate	1	0.1	0.01	800	2000	200	20	100 +/- 1.5	2.5
	Low	1	0.1	0.01	12	1500	150	12	100 +/- 1.5	125

* Test times are calculated based on test volume in Gallons.

Test Troubleshooting

Test conditions such as those defined in the following tables can occur.

Table 15 – Meter is Under Registering

Possible Cause	Remedy
Air in Line	Flush the meter a little longer with a higher back pressure and flow rate if possible, then try again. To flush the meter, loosen the meter bleed screw (See Figure 5 "Bleed Screw Details" on page 11) located on top of the meter one to two turns. Release air through the bleed screw until water begins to flow from the screw location. After this occurs, fully re-tighten the meter bleed screw.
Incorrect Start Read or End Read	Confirm reference reads and the test bench are correct. Test the meter again. If using a volumetric test tank, be sure to "wet" the tank before conducting the meter test.
Insufficient Resolution on the Register	Increase test quantity size. For more detailed explanation of register resolution, see "Activating and Reading C&I MACH 10® Ultrasonic Meters" on page 23.
Improper Purge of Lines	It is important to have all air removed from the water lines prior to initiating the tests. See the previous instructions for air in the line to purge the water lines.
Improper Back Pressure	To properly test the meter, be sure there is at least 30 psig of back pressure on the meter.

Table 16 – Meter is Over Registering

Possible Cause	Remedy
Leak Downstream of the Meter	Inspect test bench to ensure it is free of leaks.
Incorrect Start Read or End Read	Confirm reference reads and the test bench are correct. Test the meter again. If using a volumetric test tank, be sure to “wet” the tank before conducting the meter test.
Insufficient Resolution on the Register	Increase test quantity size. For more detailed explanation of register resolution, see "Activating and Reading C&I MACH 10® Ultrasonic Meters" on page 23.
One Isolation Valve on Test Bench is Partially Open	Ensure valves that are not in use are turned to the off position.

Table 17 – Meter Stops Registering During a Test

Possible Cause	Remedy
Air in Line	When air is in the line, the registered flow may stop or decrease. Air must be purged completely, or test results continue to be uncertain. Purging air can be achieved by loosening the meter bleed screw (See Figure 6 on page 11) located on top of the meter by one or two turns. Release air through the bleed screw until water begins to flow from the screw location. After this occurs, fully re-tighten the meter bleed screw.

Table 18 – Meter Does Not Register Water When Running a Test

Possible Cause	Remedy
Air in Line	Flush the meter a little longer with a higher back pressure and flow rate if possible, then try again. To flush the meter, loosen the meter bleed screw (See Figure 6 on page 11) located on top of the meter one to two turns. Release air through the bleed screw until water begins to flow from the screw location. After this occurs, fully re-tighten the meter bleed screw.

Table 19 – Meter Does Not Register on Automated Test Bench

Possible Cause	Remedy
Bench Configuration	Consult your test bench supplier to modify / adjust the test bench profile to conform to the test conditions outlined in this guide.

Chapter 7: Maintenance and Troubleshooting

This chapter provides information for maintaining and troubleshooting the C&I MACH 10[®] meter.

Maintenance

Typically, mechanical meters are subject to wear and are often rebuilt to extend their life. The electronic C&I MACH 10 meter does not have moving parts and requires no maintenance. The C&I MACH 10 meter is designed with the electronics, transducers, battery, and display all as part of a Unitized Measuring Element (UME) which you can replace on the meter without removing the meter maincase from service, eliminating maintenance time and cost.

Unitized Measuring Element (UME) Maintenance

When maintenance is necessary, you can quickly and easily interchange the complete UME with a factory-calibrated unit. The UME includes the register, cover, batteries, and measurement transducers.

Following are the steps to replace the UME.

1. Close all valves (mainline and bypass).
2. Open the bleed screw on top of the meter to vent air.
3. Make sure the meter is depressurized.
4. Remove the cover bolts.
5. Remove the UME from the maincase.
6. Install the factory-calibrated UME into the maincase as shown in the following image.

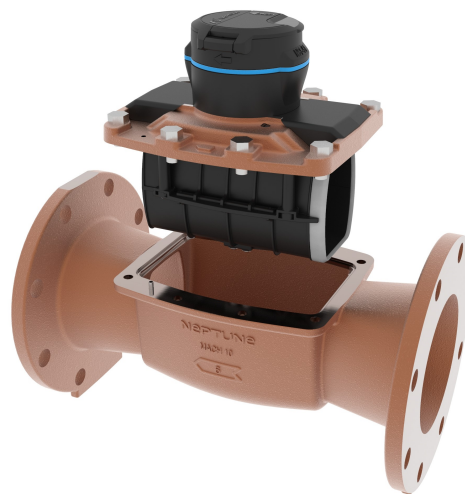

Figure 21 – Unitized Measuring Element Commercial and Industrial MACH 10[®] Meter

7. Replace the supplied UME gasket, if necessary.



When replacing the UME, ensure that the gasket is seated properly and not twisted or pinched before seating new UME.

8. Replace the cover bolts as shown in the previous image.
9. Tighten the cover bolts.
10. Open the valves.

All new UMEs have been factory tested and do not require field testing. If no spare unit is available, you can purchase a factory-calibrated UME directly from Neptune or one of its authorized distributors.

Replacement Parts

If the plastic meter lid becomes damaged or broken, it can be replaced. The UME assembly may also be replaced, but there are no other replacement parts for the C&I MACH 10 ultrasonic meter.

General Troubleshooting

The following tables provide steps for troubleshooting common issues with the C&I MACH 10 meter.

Table 20 – LCD Display Does Not Illuminate

Possible Cause	Remedy
Environment is too dark	Shine a flashlight on the face of the register. Remove the light after the display wakes up.
LCD has timed out	<ul style="list-style-type: none"> • Close the lid of the register. • After a few seconds open the lid. If the LCD still does not come on, see “Possible Cause: Environment is too dark” above.
Photo-eye is blocked	Clean the face of the register to remove any dirt and debris, and then follow the steps in “Possible Cause: LCD has timed out” above.

Table 21 – Endpoint or LCD Display Reports Errors

Possible Cause	Remedy
Intermittent or continuous flow	Depending on the application of the meter, intermittent or continuous flow may be expected. If such flow is unexpected, check the integrity of the line downstream the meter.

Table 21 – Endpoint or LCD Display Reports Errors (continued)

Possible Cause	Remedy
Reverse flow	Some reverse flow may be expected depending on your configuration. You may need to install a backflow preventer upstream of the meter if significant negative flow is reported.
Excessive Forward Flow	Excessive flow may cause the endpoint to report question marks (?) and the display to read zero flow. The unit displays the last known valid volume. Ensure the meter is installed in an application that is within the Normal Operating Flow Range for its size.
Empty Pipe	Remove all air from the meter during installation. Neptune recommends flushing the line multiple times to ensure no air is retained within the system. Trapped air may cause the display and MIU to report values that do not reflect actual usage.
Low Battery	If the battery is low, consider replacing the UME.

Checklist

Before leaving the installation site, be sure to do the following.

- Record the endpoint ID for each register.
- Verify that you have followed all requirements of this Installation and Maintenance Guide.
- Verify that you have recorded all required information.
- Clean up any installation debris.
- Verify that the requirements of the Site Work Order have been completed.
- Inform the customer that you have completed your work. If you were unable to finish, inform the customer when you are returning to complete the project.

Contact Information

Within North America, Neptune Customer Support is available Monday through Friday, 7:00 A.M. to 5:00 P.M. Central Standard Time, by telephone or email.

By Phone

To contact Neptune Customer Support by phone, complete the following steps:

1. Call **(800) 647-4832**.
2. Select one of the following options:
 - **1** if you have a Technical Support Personal Identification Number (PIN).
 - **2** if you do not have a Technical Support PIN.
3. Enter the six-digit PIN and press #.
4. Select one of the following options:
 - **2** for Technical Support.
 - **3** for maintenance contracts or renewals.
 - **4** for Return Material Authorization (RMA) for Canadian Accounts.

You are directed to the appropriate team of Customer Support Specialists. The specialists are dedicated to you until the issue is resolved to your satisfaction. When you call, be prepared to give the following information:

- Your name and utility or company name.
- A description of what occurred and what you were doing at the time.
- A description of any actions taken to correct the issue.

By Email

To contact Neptune Support by email, send your message to support@neptunetg.com.

This appendix provides a general description of the C&I MACH 10[®])R900i™.

Product Description

The C&I MACH 10 is manufactured by Neptune and is an integrated register that contains both the C&I MACH 10 meter and the R900[®] radio technologies in one register that collects reading data. It then transmits the data for collection by the meter reader. A Neptune walk-by, mobile, or R900[®] gateway fixed network data collection system receives the data and stores it to be downloaded into the utility billing system for processing.

The C&I MACH 10 is easily installed and operates within a Radio Frequency (RF) band, which does not require an operating license. The C&I MACH 10 meets FCC regulations part 15.247 allowing higher output power and greater range. The C&I MACH 10 uses frequency-hopping spread spectrum (FHSS) technology to avoid RF interference and enhance security.

The transmitted data is updated at 15-minute intervals. It transmits a mobile message that includes the meter reading data and the unique 10-digit C&I MACH 10 ID every 14 to 20 seconds. This allows the meter to be read by a handheld unit (HHU) or mobile data collection unit. The C&I MACH 10 also transmits a high-power fixed network message every 7½ minutes on an interleaved basis to a fixed R900[®] gateway.

The C&I MACH 10 is designed to offer advantages to utility organizations of all sizes:

- Increases meter reading accuracy.
- Eliminates reading difficulties.
- Protects utility liability by increasing meter reader safety.
- Requires no external wiring or programming.
- Provides enhanced eight-digit AMR meter reading.
- Provides proactive customer service benefits (leak, tamper, and backflow detection).

MACH 10[®])R900i™ Programming

The C&I MACH 10 is not field-programmable. Each endpoint is given a unique 10-digit serial number / identification number.

RF Protocol Error Detection

The RF protocol includes a header, data packet, and an error detection mechanism that reduces the erroneous data.

MACH 10®)R900i™ Specifications

This section provides you with the specifications for the C&I MACH 10.

Dimensions – Commercial and Industrial

The following images show the dimensions of the C&I MACH 10.

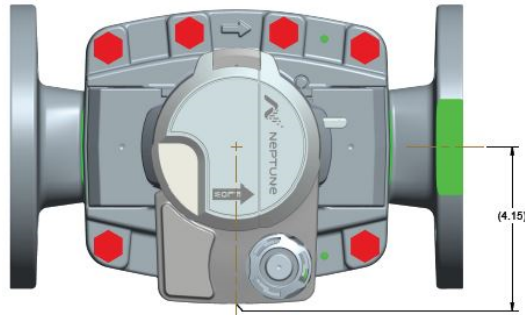

Figure 22 – Commercial and Industrial MACH 10®)R900i™ – Top View

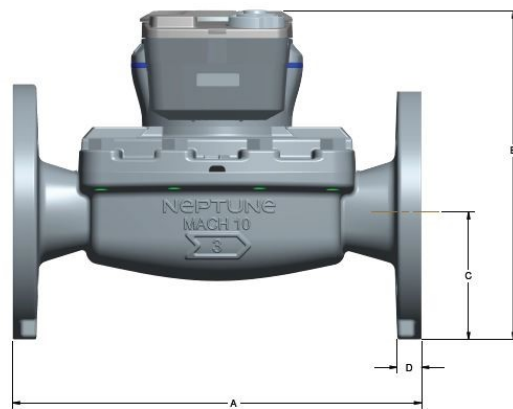

Figure 23 – Commercial and Industrial MACH 10®)R900i™ – Front View

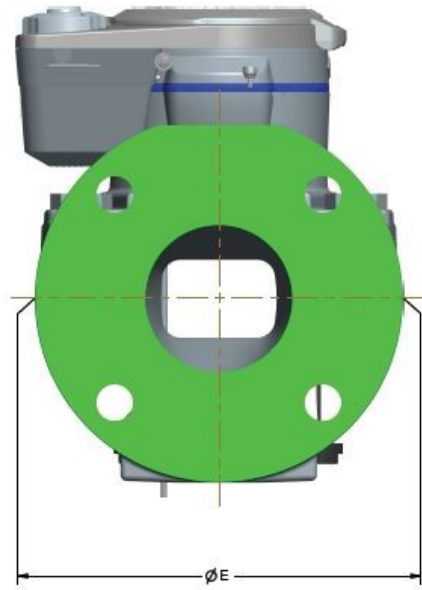

Figure 24 – Commercial and Industrial Meter Dimensions – End View



The width dimension of the meter with an installed R900i integrated radio only affects the three-inch and four-inch sizes. The six-inch meter is not affected as the communications module does not exceed the meter case.

The following table defines the dimensions of the C&I MACH 10 meters. All dimension measurements are in inches.

Table 22 – MACH 10®R900i™ Meter Dimensions – Commercial and Industrial

Meter	A	B	C	D NSPM
3 inch	12.00" or 17.00"	9.65"	3.75"	.71"
4 inch	14.00" or 20.00"	10.94"	4.50"	.71"
6 inch	18.00" or 24.00"	12.73"	5.50"	.71"
8 inch	20.00"	15.72"	6.75"	1.13"
10 inch	26.00"	17.91"	7.96"	1.13"
12 inch	19.70"	19.98"	9.46"	1.13"

Electrical Specification

Power is provided by a lithium thionyl-chloride battery.

Transmitter Specifications

The following table defines the specifications for the C&I MACH 10 transmitter.

Table 23 – Transmitter Specifications

Specification	Description
Transmit Period	<ul style="list-style-type: none"> • Every 14 to 20 seconds – standard mobile message. • Every 7½ minutes – standard, high power, fixed network message.
Transmitter Channels	50.
Channel Frequency	910 to 920 MHz.
Output Power	Meeting FCC Part 15.247.
FCC Verification	Part 15.247.

Functional Specifications

The following table defines the functional specifications for the MACH 10)R900i.

Table 24 – Functional Specifications

Specification	Description
Register Reading	<ul style="list-style-type: none">• Eight digits (AMR).• Nine digits (Visual).
MIU ID	10 digits.

This page intentionally left blank.

Appendix B: C&I MACH 10[®])R900[™] Flags

The three tables in this appendix describe the volume represented by the eighth digit by meter size and the flags used by the Commercial and Industrial MACH 10[®])R900ⁱ (digits) and MACH 10[®])R900ⁱ (minutes).

Table 25 – Eighth Digit Resolution by Meter Size – Commercial and Industrial

Register Size	Eighth Digit Resolution - Least Significant Digit
3 inch and 4 inch	1 U.S. Gallon or 1/10 Cubic Feet
6 inch through 12 inch	10 U.S. Gallons or 1 Cubic Foot

Table 26 – MACH 10[®])R900[™] Flags (digits)

Backflow Flag (Resets After 35 Days)	
Based on reverse movement of the eighth digit; eighth digit is variable based on the meter size.	
No backflow event	Eighth digit reversed less than one digit.
Minor backflow	Eighth digit reversed more than one digit up to 100 times the eighth digit.
Major backflow event	Eighth digit reversed greater than 100 times the eighth digit.

Table 27 – MACH 10®)R900i™ Flags (minutes)

Leak Status Flag (Resets After 35 Days)	
Based on total amount of 15-minute periods recorded in the previous 24-hour period.	
Leak icon off	Eighth digit incremented less than 50 of the 96 15-minute intervals.
Flashing leak icon	Eighth digit incremented in 50-95 of the 96 15-minute intervals.
Solid leak icon	Eighth digit incremented in all of the 96 15-minute intervals.
Consecutive Days with Zero Consumption Flag (Resets After 35 Days)	
Number of days the leak status was at a minimum value.	

A

AMI

Advanced Metering Infrastructure. A system that captures, stores, and provides to the utility at frequent intervals detailed consumption and other information, such as, usage, leak, and flow status, to support advanced applications.

AMR

Automated or Automatic Meter Reading.

AWWA

American Water Works Association.

C

C&I

Commercial and Industrial.

E

Empty Pipe

Condition whenever the measurement section of the meter is not completely filled with water.

L

LCD

Liquid Crystal Display.

light sensor

Component located under the recess that is used to activate the Liquid Crystal Display (LCD).

M

MIU

Meter Interface Unit, which is an endpoint in the utility network.

MUT

Meter Under Test.

P

psig

Pressure in pounds per square inch (psi) relative to atmospheric pressure, as typically shown on a pressure gauge.

S

serial number

Unique identification number given to each meter at the factory. The default value is the last programmed plus one. Custom serial numbers are not available.

T

transceiver

Device that transmits and receives communications, in particular a combined radio transmitter and receiver.

transducer

Device that converts one form of energy to another form of energy.

transit-time

Technology that takes advantage of the principle that an acoustic signal travels faster with the flow than against the flow.

U

ultrasonic flow

Use of ultrasonic technology to measure the velocity of an acoustically conductive liquid or gas moving through it. The velocity of the water is then converted to volume throughput using sophisticated algorithms and electronics.

ultrasonic meter

Electronic meter using ultrasonic technology and solid state electronics contained in a compact, totally encapsulated, weatherproof, and ultraviolet (UV) resistant housing for residential and light commercial applications.

UME

Unitized Measuring Element.

This page intentionally left blank.

A

accuracy, meter testing guidelines 29
acoustic signal 2
acoustically 2
alarm 11, 24
algorithms 2
AMI 1, 4
AMR 1

B

backflow 47
battery 2, 37
 requirements 8
bench testing 29
bleed screw 31

C

calculated velocity 3
calibrated 10
checks
 preliminary 10
 safety 10
color codes for wires 18
conductive 2
connections 19

consumption 23, 26
contaminants 2
crimping tool 18
customer support 40

D

debris 16
dimensions
 Commercial and Industrial MACH 10®
 R900i™ 6
 Commercial and Industrial MACH 10®
 R900™ 42

E

E-CoderPLUS 1

F

fire service 8
fixed network 41
flags 47
flashlight 9
flow rate 12

G

grounding strap 16

H

hopping, frequency 41

I

icon

- battery status 25
- empty pipe 25
- forward and reverse flow 25
- high flow warning 25
- leak 25

installation

- guidelines 9
- meter 10

installing 13

integrated 4

L

LCD 23

- panel 23

light sensor 23

M

MACH 10® 1

- R900i 41
 - flags 47
 - programming 41
 - specifications 42
 - transmitter 44

maincase 8

maintenance 37

meter

- display 23
- sizing 12

O

operating license 41

Other Term

- Subterm 7, 25, 44

output 27

P

piezoelectric 8

pipng 10

potted 3, 27

pressure vessel 8

procedure, test 30

product description 1

PURGE setting 31

R

reading resolution 27

recommended

- materials 9
- tools 9

register

- display 5
- type 5

resolution 26

retrofit 10

RF

- band 41
- protocol error 41

S

- service line 16
- setting, PURGE 31
- specifications
 - C&I MACH 10®)R900i™ 42
 - C&I MACH 10®)R900™ 5

T

- temperature, water 10
- test troubleshooting 35
- testing equation
 - cubic feet 30
 - gallons 30
- toolkit 9
- transceivers 2
- transducers 2, 8
- transit-time 2
- troubleshooting 37

U

- UME 7, 37

V

- velocity range 8

W

- water flow 10

This page intentionally left blank.



Neptune Technology Group Inc.

1600 Alabama Highway 229
Tallasse, AL 36078
USA Tel: (800) 633-8754
Fax: (334) 283-7293

Neptune Technology Group Canada Co.

7275 West Credit Avenue
Mississauga, Ontario L5N 5M9
Canada Tel: (905) 858-4211
Fax: (905) 858-0428

Neptune Technology Group Inc.

Avenida Ejercito Nacional No 418
Piso 12, Despacho 1203
Colonia Polanco V Sección
C.P. 11560 Delegación, Miguel Hidalgo
Mexico D.F.
Tel: (55) 5203-5708, (55) 5203-4032,
(55) 5203-5294

Online
www.neptunetg.com

