

AMERICAN AVK COMPANY

AVK SERIES 2780 - HIGH PRESSURE, NOSTALGIC, DRY BARREL HYDRANT FIELD MAINTENANCE AND INSTRUCTION MANUAL

TABLE OF CONTENTS

- EXPLODED ASSEMBLY / PARTS LIST
- INTRODUCTION / DESCRIPTION
- RECEIVING AND STORAGE
- INSTALLATION AND TESTING
 - INSTALLATION
 - TESTING
- OPERATION AND MAINTENANCE
 - HYDRANT TOOLS
 - OPERATION
 - MAINTENANCE PROCEDURES
 - LUBRICATION
 - INSPECTION
 - DISASSEMBLY FOR INSPECTION
 - REASSEMBLY AFTER INSPECTION
- REPAIR PROCEDURES
 - TRAFFIC REPAIR KIT
- OPTIONAL EQUIPMENT
 - EXTENSION KITS
 - TAMPERGUARD WEATHERSHIELD
 - THRUST BEARING OPERATING ASSY.
- TROUBLESHOOTING GUIDE
- PARTS AND SERVICE
- WARRANTY

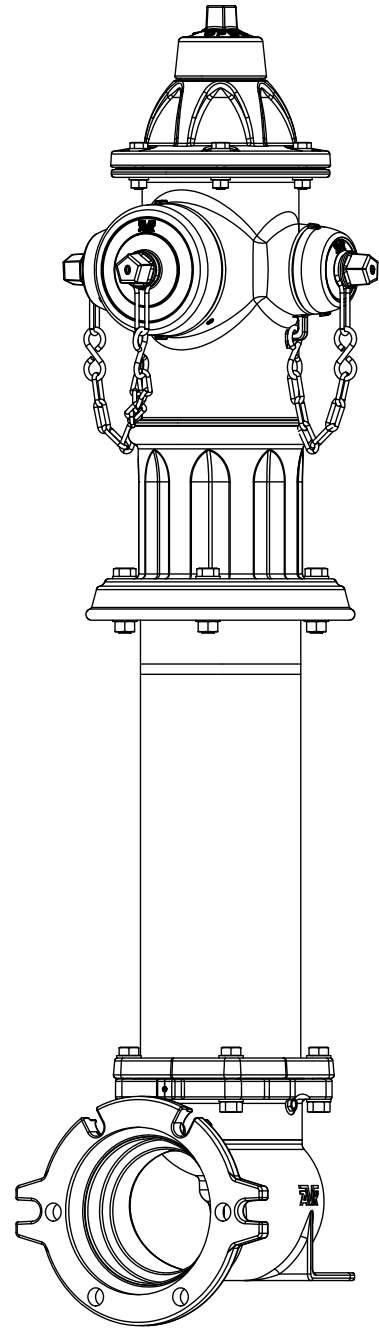

American AVK Series 2780 Nostalgic Hydrant Exploded Parts Breakdown

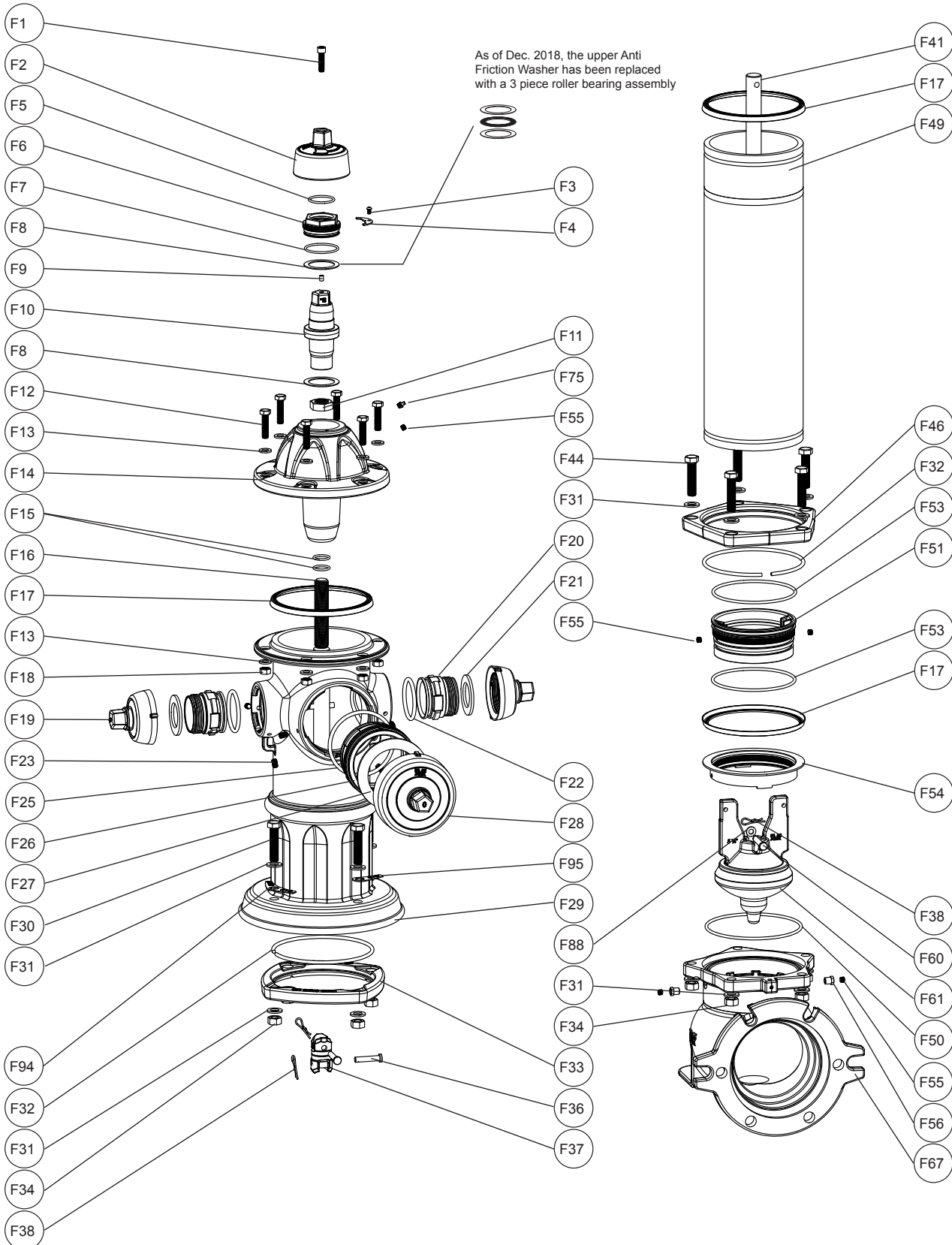

Item No.	Description	Material
F1	Weathershield Bolt	304 Stainless steel
F2	Weathershield	Grey Iron, ASTM126, Class "B"
F3	Lockplate Bolt	304 Stainless steel
F4	Lock Plate	304 Stainless steel
F5	Inner Thrust Nut O-ring	NBR
F6	Thrust Nut	Copper Alloy
F7	Outer Thrust Nut O-ring	NBR
F8	Anti Friction Washer	Nylon
F9	Lubrication Hole Seal	NBR
F10	Operating Nut	Copper Alloy
F11	Stop Nut	Zinc plated steel
F12	Bonnet Bolt	Zinc plate, 304, 316 Stainless steel
F13	Bonnet Washer	Zinc plate, 304, 316 Stainless steel
F14	Bonnet	Ductile Iron, ASTM A536
F15	Stem Seal O-rings	NBR
F16	Upper Stem Rod	304 Stainless steel, Epoxy coated steel
F17	Barrel Gasket	NBR with stainless steel insert
F18	Bonnet Nut	Zinc plate, 304, 316 Stainless steel
F19	Hose Nozzle Cap	Grey Iron, ASTM126, Class "B"
F20	Hose Nozzle	Copper Alloy
F21	Hose Nozzle Cap Gasket	NBR
F22	Hose Nozzle O-ring	NBR
F23**	Set Screw - (Nozzle)	304 Stainless steel
F24*	Chain Assembly	Zinc Plated Steel
F25	Pumper Nozzle O-ring	NBR
F26	Pumper Nozzle	Copper Alloy
F27	Pumper Cap Gasket	NBR
F28	Pumper Cap	Grey Iron, ASTM126, Class "B"
F29	Nozzle Section	Ductile Iron, ASTM A536
F30	Nozzle Section Bolt	Zinc plate, 304, 316 Stainless steel
F31	Nozzle Section Washer	304 Stainless steel
F32	Lock Ring	304 Stainless steel
F33	Breakable Flange	Ductile Iron, ASTM A536
F34	Nozzle Section Nut	304 Stainless steel
F35*	Upper Barrel	Ductile Iron, ASTM A536
F36	Coupler Pin	420 Stainless steel
F37	Breakable Stem Rod Coupling	431 Stainless steel
F38	Spring Pin	304 Stainless steel
F41	Lower Stem Rod	Mild Steel, 304 Stainless steel
F42*	Extension Coupling	304 Stainless steel
F43*	Extension Barrel	Ductile Iron, ASTM A536
F44	Upper.Extension Barrel Bolt	Zinc plate, 304, 316 Stainless steel
F45	N/A	
F46	Standpipe Flange	Ductile Iron, ASTM A536
F47*	Monitor Elbow	Ductile Iron, ASTM A536
F48*	Extension Stem Rod	Mild Steel, 304 Stainless steel
F49	Lower Barrel	Ductile Iron, ASTM A536
F50	Lower Barrel O-ring	NBR
F51	Valve Seat Ring	Copper Alloy
F52	N/A	
F53	Valve Seat O-ring	NBR
F54	Drain Ring	Copper Alloy
F55	Brass Plug	Copper Alloy
F56	Brass Fitting	Copper Alloy
F58	N/A	
F60	Main Valve Retaining Pin	420 Stainless steel
F61	Main Valve	EPDM, Encapsulated Ductile Iron
F62	Base Gasket	NBR
F63*	Straight Inlet	Ductile Iron, ASTM A536
F65	N/A	
F66	N/A	
F67	Base	Ductile Iron, ASTM A536
F68	N/A	
F69***	Thrust Bearing Race	Hardened Steel
F70***	Thrust Bearing	Hardened Steel
F71*	Modern Nozzle Section Bolt	Zinc plate, 304, 316 Stainless steel
F72*	Base Gasket - Specify type	NBR
F73*	Storz Cap O-ring	EPDM
F74*	Cap/Cable Assembly	
F75	Zerk Fitting	Case Hardened Steel, Zinc Plated
F88	Main Valve Retaining Pin Washer	304 Stainless steel
F90*	Hose Nozzle Position Clip	300 Series Stainless
F91*	Pumper Nozzle Position Clip	300 Series Stainless
F92*	Inner Storz Cap O-ring	NBR
F93*	Storz Adaptor	Copper Alloy
F94	Bury Tag	Aluminum
F95	Extension Bury Tag	Aluminum

* Not Shown in Exploded Parts Breakdown

** As of July 2015, secondary Set Screws were added to all dry barrel nozzle outlets

*** As of Dec. 2018, the upper Anti Friction Washer has been replaced with a 3 piece roller bearing assembly comprised of 2,

F69 Thrust Bearing Races and 1, F70 Thrust Bearing.

INTRODUCTION / DESCRIPTION

The American AVK Series 2780 Nostalgic Hydrant is designed to be a trouble free, easy to maintain hydrant. This manual will provide you with the information needed to properly install and maintain the fire hydrant and to ensure a long service life. Features of the American AVK Series 2780 Nostalgic Hydrant include an EPDM encapsulated one piece main valve and a stainless steel upper stem. The series 2780 is rated for a working pressure of 250 psi, is UL, ULC listed and FM approved, and meets or exceeds the requirements of AWWA C502, Standard for Dry Barrel Fire Hydrants, (where applicable). The AVK Series 2780 hydrant and hydrant tools are designed so that one person can perform all repairs and maintenance outlined in this manual.

RECEIVING AND STORAGE

Inspect the hydrants upon receipt for damage in shipment. Note any damage on the bill of lading and have the driver sign it. Notify American AVK. Unload all of the hydrants carefully to avoid damage. Verify that the hydrants have the correct direction to open, the correct nozzle configuration and threads, the correct operating nut size and shape, the correct depth of bury, and the correct inlet connection. Hydrants should remain clean and dry, and the main valve should be closed until installed to prevent weather related damage. For long term storage the hydrants should be stored indoors.

INSTALLATION AND TESTING

NOTE: American AVK recommends AWWA Standard C600 and AWWA Manual M17 for further information regarding hydrant installation and testing.

WARNING: All water lines must be isolated or depressurized and drained before installing or maintaining fire hydrants. Failure to do so may cause pressure to be released resulting in severe injury or death.

INSTALLATION

Correct installation of the Series 2780 Nostalgic Hydrant is important for proper operation. The following steps are general installation guidelines for a standard AVK Series 2780 fire hydrant. Local conditions may require variations.

1. Before installing a hydrant, check to make sure all bolts are tight and all nozzles are properly installed (See NOZZLE INSTALLATION). Clean any dirt and debris from inside the hydrant base and from the hydrant lead.
2. All hydrants shall be installed as plumb as possible.
3. Consult local codes and standard for hydrant placement. In general, the following guidelines should be observed. Locate hydrants to provide complete accessibility while minimizing the possibility of damage from vehicles or injury to pedestrians. The hydrant should be placed so that no part of the hydrant is closer than two feet to the curb. Make sure the pumper nozzle faces the street for easy connection. The centerline of the hydrant nozzles should be no less than 18-inches above the ground to allow for attachment of hoses and to operate the hydrant wrench.
4. Always install auxiliary gate valve in the lateral between the hydrant and the main to permit inspection and repair of the hydrant.
5. On traffic hydrants, be sure the earth is firmly compacted around the barrel to support the lower barrel against side loading. If the soil is too sandy and will not support the loads, pour a concrete pad around the barrel at or near the bury line at least 6 inches thick and 24 inches in diameter to support the barrel.
6. Place clean coarse gravel or crushed stone from the bottom of the trench to at least 6 inches above the drain opening in the hydrant and to a distance of 1 foot around the elbow to provide drainage. For clay or other impervious soils, excavate a drainage sump 2 feet in diameter and 3 feet deep below each hydrant. Fill the sump with clean coarse gravel or crushed stone to a level 6 inches above the drain opening. Place a plastic sheet over the gravel to prevent dirt from clogging the drains.
7. Restrain hydrant movement with appropriate thrust blocking or restrained joint to prevent pipe joint separation.
8. When first installed, the hydrant should be operated from full closed to full open position and back to make sure no obstructions are present.
9. After the line and hydrant have been hydrostatically tested, the hydrant should be flushed and then checked for proper drainage.
10. AWWA Manual M17 has further guidelines to assist with hydrant installation

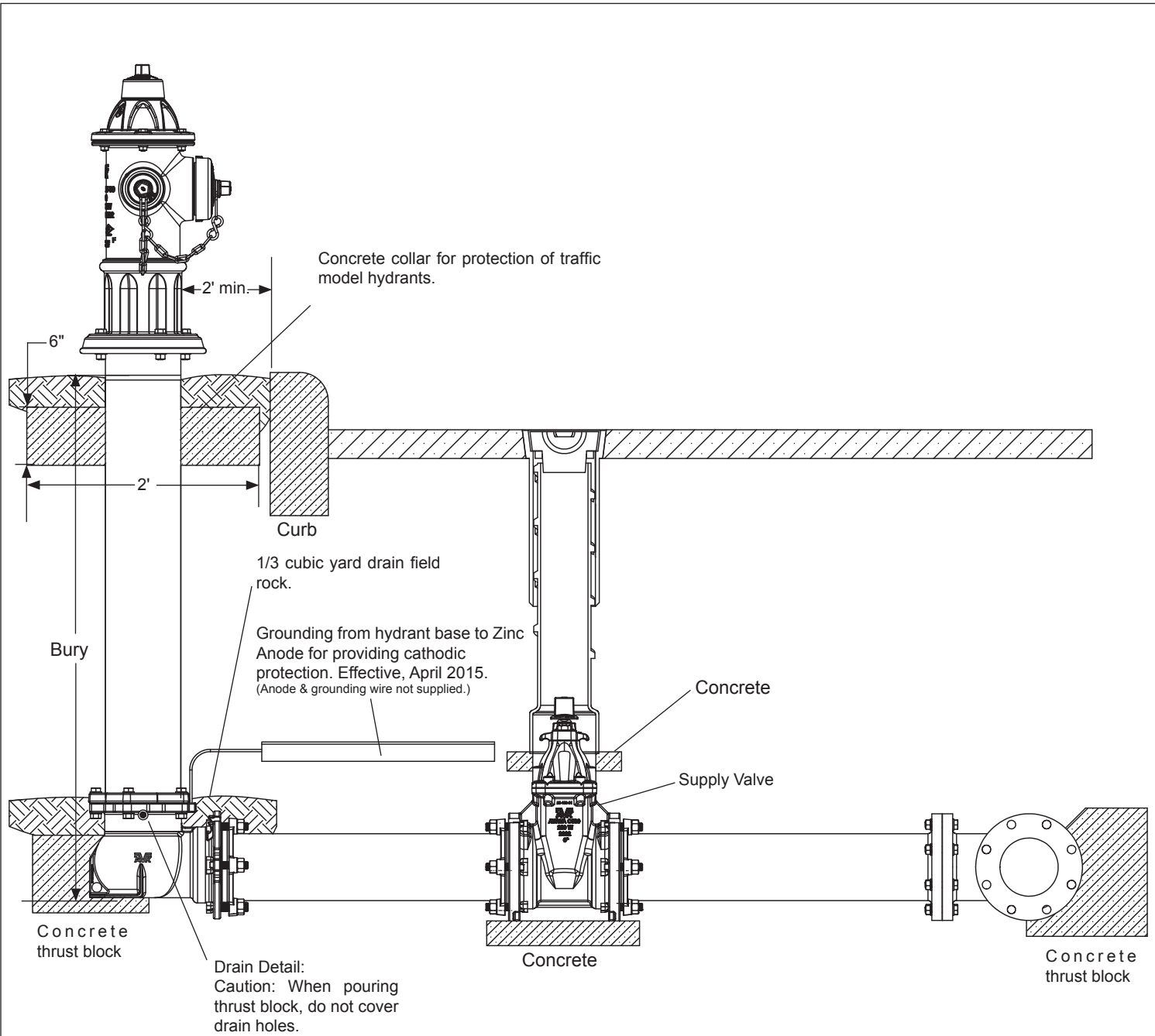

Fig. 1
Hydrant Installation

PRESSURE TESTING

American AVK Recommended Hydrant Testing Procedure

AAVK recommends that AWWA M17, "Installation, Field Testing, and Maintenance of Fire Hydrants", chapters 4.3 and 4.4 be followed for field testing and placing the hydrant in service. The following is excerpted from AWWA M17 for the reader's convenience:

PRESSURE TEST AT MAIN PRESSURE

1. Ensure that all nozzles are properly installed per section "NOZZLE INSPECTION & REPLACEMENT"
2. Remove the highest outlet-nozzle cap and open the hydrant valve a few turns. Allow water to reach the bottom of the outlet nozzle. (If the hydrant is furnished with a tapped-plug air vent, then it is not necessary to remove the nozzle cap. Just open the air vent.)
3. Replace the outlet-nozzle cap and leave it loose to permit all air to escape, or close the tapped-plug air vent.
4. After all air has escaped, tighten the outlet-nozzle cap.
5. Open the hydrant completely. (Opening the hydrant fully before all air has escaped will compress the air and cause a safety hazard.) **(AAVK comment: underlined as very important)**
6. Check for leakage at flanges, outlet nozzles, and the packing or O-rings around the stem.
7. If leakage is noted, repair or replace the faulty components or the entire hydrant. **(AAVK comment: only after hydrant is closed and all pressure is bled off.)**
8. Repeat the test until results are satisfactory.

PRESSURE TEST AT PRESSURES ABOVE MAIN PRESSURE

1. Connect a pressure-test pump to one of the hydrant's outlet nozzles.
2. Open the highest outlet-nozzle cap. Open the hydrant valve a few turns. Allow the hydrant to fill until water is at the bottom of the outlet nozzle.
3. After all air has escaped, tighten the outlet-nozzle cap.
4. Open the hydrant completely.
5. Close the auxiliary valve.
6. Pump up to test pressure (usually 150 psi [1034 kPa]).
7. Check for leakage at flanges, outlet nozzles, and the packing or O-rings around the stem.

DRAINAGE TEST

1. Remove one of the Hose Caps (F19) and fill the hydrant with water.
2. With the hydrant in the closed position, place the palm of one hand over the open Hose Nozzle (F20). As the water drains from the hydrant it should create a noticeable vacuum indicating proper drainage.
3. For further instructions refer to the AWWA M-17 Hydrant Manual, Chapter 4.3.

EXTERNAL DRAIN PLUGGING

American AVK offers the option of External or Internal Drain Facility Plugging.

1. Prior to installation, for external plugging, visually verify for factory installed plugs or screw two Brass Plugs (F55) into the Brass Fittings (F56) located on the Main Valve Flange (F57) using a 3/16" hexagon key.

INTERNAL DRAIN PLUGGING

1. For internal plugging, refer to the warnings and steps in the "MAIN VALVE INSPECTION" section on page 14.
2. After removing the main valve assembly, screw in two Brass Plugs (F55) into the Valve Seat Ring (F51) using a 3/16" hexagon key.(Fig. 2)
3. Inspect the main valve assembly prior to re-installation. Replace any damaged items and follow the steps in the "MAIN VALVE REREASSEMBLY" section on page 15 .

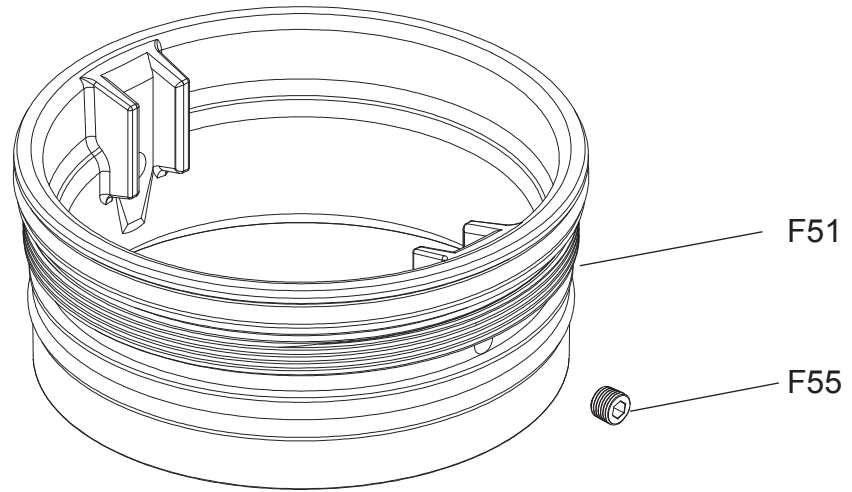

Fig. 2
Internal Drain Plugging

OPERATION AND MAINTENANCE

HYDRANT TOOLS

American AVK offers a standard toll kit for routine maintenance requirements. The kit is comprised of the following AVK specific tools.

- | | |
|---|-----------------------------|
| 1. AVK Seat Wrench:
For use in removal and replacement of the MAIN VALVE/ SEAT | Part Number: 27-150-301-001 |
| 2. AVK Oilsaver Adapter | Part Number: 27-150-30300 |
| 3. AVK Operating Wrench | Part Number: 27-150-307-001 |
| 4. AVK Seat Wrench Alignment Tool | Part Number: 27-150-305-001 |

METRIC AND INCH WRENCH REQUIREMENTS FOR AMERICAN AVK HYDRANTS

PART	INCH SIZE	METRIC SIZE
Weathershield Retaining Bolt (Allen)	5/16"	8mm
Thrust Nut Retaining Screw (Allen)	5/32"	4mm
Nozzle Retaining Screw (Allen)	3/16"	5mm
Bonnet Bolts and Nuts	3/4"	19mm
All other Bolts and Nuts	15/16"	24mm

Main Valve removal end

AVK Seat Wrench
27-150-301-001

Stop Nut removal end

AVK Oilsaver
27-150-30300

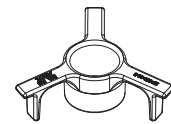

AVK Seat Wrench
Alignment Tool
27-150-305-001



AVK Operating Wrench
27-150-307-001

OPERATION AND MAINTENANCE

OPERATION

The American AVK Series 2780 Nostalgic Hydrant is designed to be an easily operated, low torque, high flow fire hydrant. It will not require excessively high loads to operate. It is possible to damage the hydrant by forcing it beyond its normal operational limits.

The thrust bearing hydrant requires a minimum of torque to operate. It is possible to damage the hydrant by forcing it beyond its limits of travel with excess torque; therefore:

1. Check direction of opening as marked on the hydrant Weathershield (F2).
2. To open, turn the Operating Nut (F10), in the opening direction, indicated by an arrow on the Weathershield (F2), until the Main Valve (F61), is fully open. (Approximately 19 to 21 turns) The Stop Nut (F11), should prevent the hydrant from opening beyond the fully open position. **Do not force the hydrant in the opening direction beyond full open as indicated by sudden resistance to turning.** If water does not flow when the hydrant is open, it is probably due to a closed valve upstream from the hydrant.
3. To close, turn the operating nut until the Main Valve stops off the flow. It is not necessary to close this style of hydrant with great force. Once the flow has stopped, loosen the operating nut in the opening direction, 1/2 to 1 turn to take the strain off the operating parts of the hydrant and to make it easier to open the hydrant.

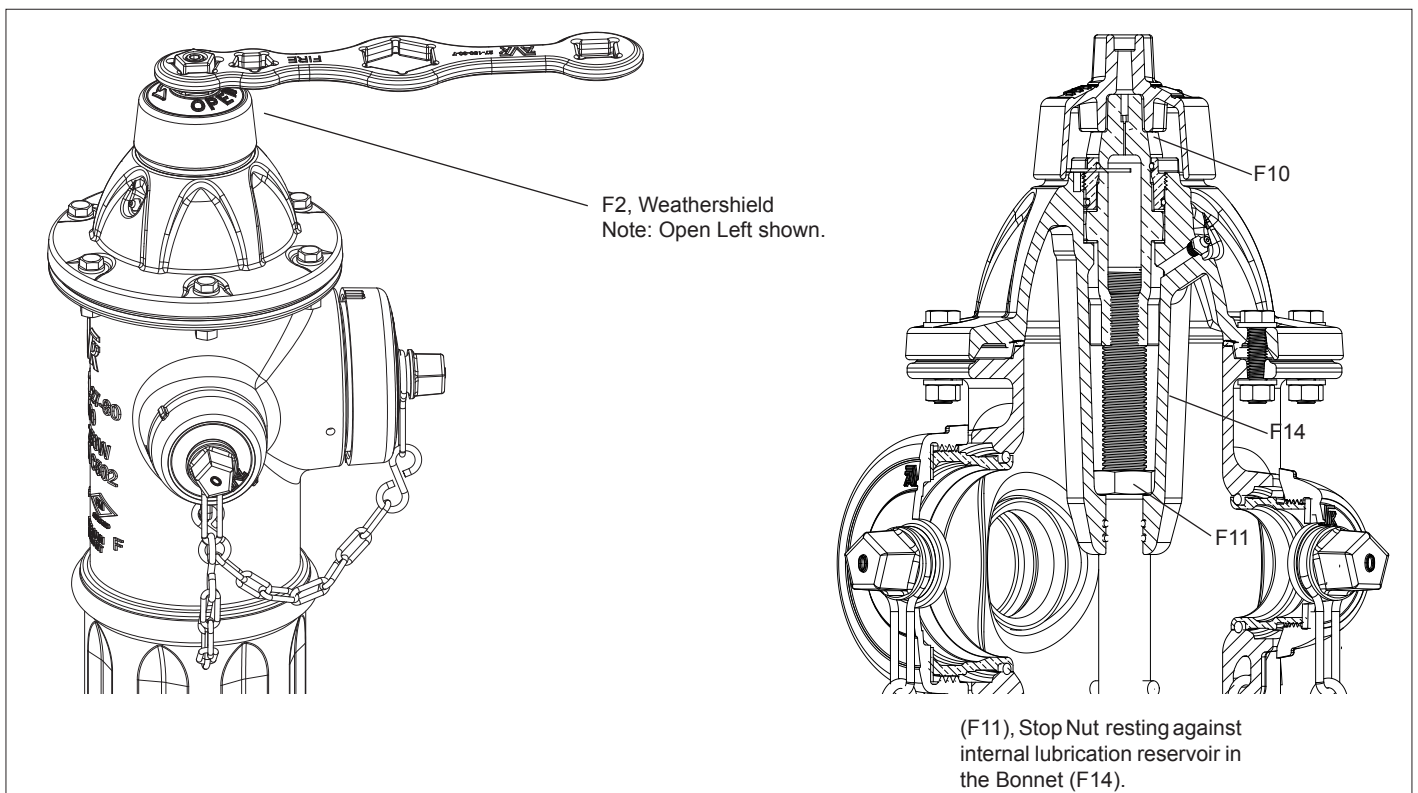

Fig. 3
Operation

MAINTENANCE PROCEDURES

The American AVK Series 2780 Dry Barrel Hydrant is designed to be a trouble free, easy to maintain hydrant. The following steps are recommended to provide trouble free operation.

GREASE LUBRICATION (Fig. 4A)

WARNING: On a partially disassembled hydrant under line pressure, pressing down on the stem could force open the Main Valve (F61) and allow it to slam shut, creating a water hammer. To prevent this during routine maintenance, first locate and be sure the supply valve is closed. Relieve the pressure on the Main Valve (F61) by momentarily opening and then closing the hydrant. Reopen the supply valve after the hydrant has been reassembled.

GREASE SERVICING FOR BONNETS WITH ZERK FITTINGS, (Fig. 4A)

CAUTION: For grease servicing, ensure that the Weathershield bolt has been loosened to prevent damage to the internal O-rings.

1. Refilling is performed by loosening the Weathershield bolt (F1) with a 5/16" or (8mm) hexagon key.
2. Refill lubricant reservoir with a food grade grease using a Grease gun on the Zerk Fitting (F75).
3. Tighten the Weathershield Bolt.

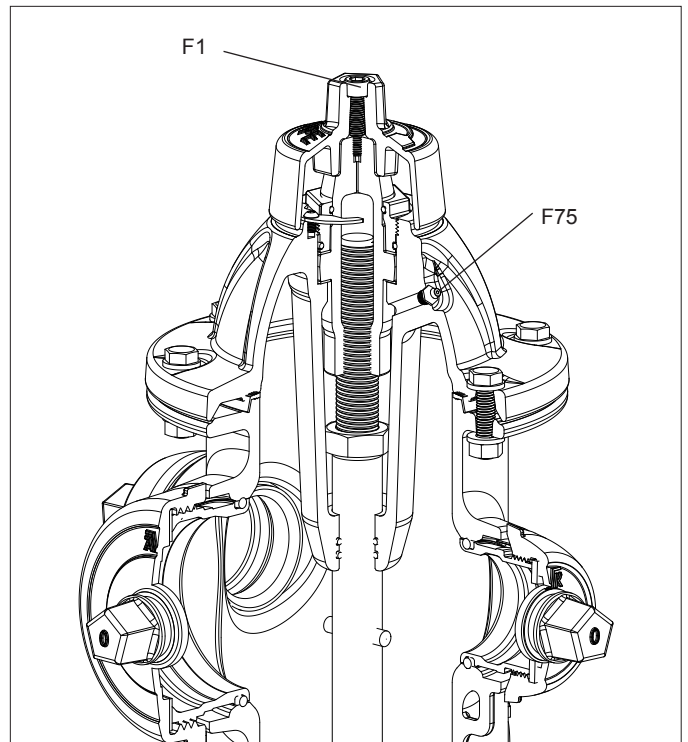

Fig. 4A
Grease lubrication for bonnets
with zerk fittings

OIL LUBRICATION (Fig. 5A)

WARNING: On a partially disassembled hydrant under line pressure, pressing down on the stem could force open the Main Valve (F61) and allow it to slam shut, creating a water hammer. To prevent this during routine maintenance, first locate and be sure the supply valve is closed. Relieve the pressure on the Main Valve (F61) by momentarily opening and then closing the hydrant. Reopen the supply valve after the hydrant has been reassembled.

OIL SERVICING FOR BONNETS WITH BRASS PLUG, FIGURE 5A

1. Loosen the Weathershield bolt (F1) with a or 5/16", (8mm) hexagon key. This will allow the oil reservoir to breath and be filled faster.
2. Remove the Brass Plug (F55) with a 3/16" hexagon key. Refill the oil reservoir with FDA approved food grade oil.
3. Install the Brass Plug and tighten the Weathershield Bolt. This should be done after any repairs or as required by local specifications.

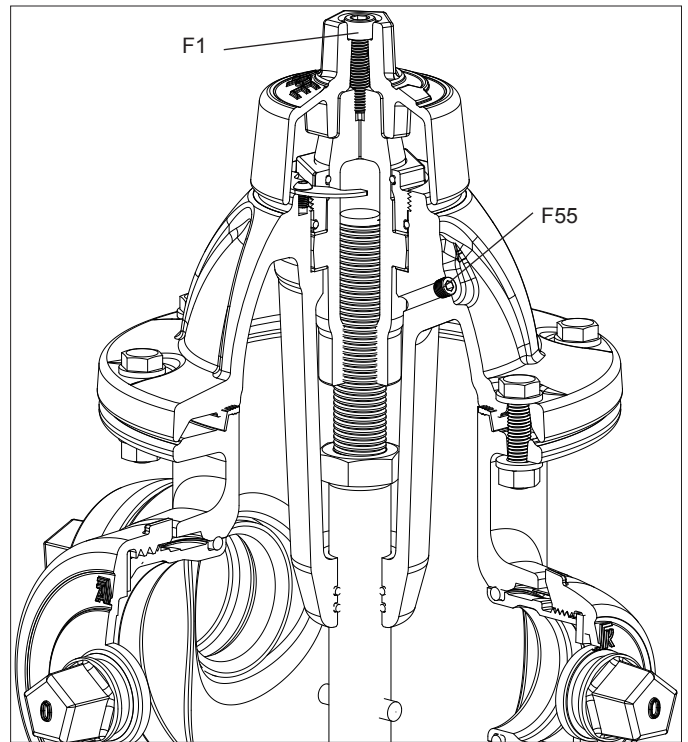

Fig. 5A
Oil lubrication for bonnets
with brass plug

INSPECTION

NOZZLE DISASSEMBLY FOR INSPECTION: FIGURES 6A-6J

If inspection of the fire hydrant is required, follow the DISASSEMBLY FOR INSPECTION instructions.

WARNING: For all of the following repair procedures, the hydrant must be isolated or the system depressurized and drained before removing the hydrant components. Failure to do so may cause pressure to be released resulting in severe injury or death.

NOZZLE INSPECTION

NOTE: If the hydrant is leaking from any of the nozzles, first try to determine if they are leaking from the Hose Cap Gasket (F21), or the Hose Nozzle O-ring (F22), and perform the applicable seal replacement procedure for the nozzle(s) in question.

NOTE: As of July, 2015, American AVK series 27 dry barrel hydrants have a secondary Nozzle Retaining Screw (F23), installed on every outlet. All Nozzle Retaining Screws are concealed and painted over at the factory.

WARNING: Hydrants with secondary Nozzle Retaining Screws that are exposed should be carefully inspected prior to use as this may indicate that the hydrant outlets have been tampered with.

Proper Nozzle Alignment:

1. Remove the Hose Nozzle Cap (F19), or Pumper Nozzle Cap (F28), using an AVK Hydrant Wrench or adjustable hydrant wrench.
2. Locate the Nozzle Retaining Screw (F23) holes. They are located approximately $\frac{1}{2}$ ", in from the edge of the nozzle section and at about the 4:30 to 8:30 positions when facing the nozzle. Remove the putty/foil concealing the screws.
3. If the retaining screw is missing, ensure that the nozzle is correctly installed as shown in fig. "6G", (for Hose Nozzles), "6J", (for Pumper Nozzles), then immediately replace it (F23 - Nozzle Retaining Screw, M10mm x 16mm, 304 stainless steel).
4. For Hose Nozzles (F20), there should be a small "dimple" or punch mark on the hose nozzle. This mark should be in alignment with the Nozzle Retaining Screw (F23) as shown in figure "6G".
5. For Pumper Nozzles, the "dimple" or punch mark is on the face of the cap end of the pumper nozzle as shown in figure "6J".
6. If the dimple is not in alignment with the retaining screw (F23), remove the retaining screw and rotate the nozzle until the alignment is correct.
7. Apply a drop of thread-locker (Loctite #242 or equal) to the end of the retaining screw, tighten it until it just contacts the nozzle, do not back off the locking screw.
8. Replace the hose nozzle cap (F19).
9. If required, repeat steps 1 through 8 for the other nozzles.

AVK hydrants manufactured before 2005 may not have the position marks ("dimples" or punch marks) on the hose and pumper nozzles. In this case, follow the following steps to add the indicators to ensure correct nozzle positioning:

1. Remove the hydrant nozzle caps.
2. Using a 3/16" or 5mm Allen wrench, remove the Nozzle Retaining Screws (F23).
3. Rotate the nozzles in a clockwise direction approximately 40 degrees until the nozzle slot aligns with lug opening on the nozzle section, located at the 6 o'clock position. See Fig. "6F".
4. Pull the cap/nozzle assembly outward until the nozzle lugs are between the nozzle section lugs as shown in Fig. "6C".
5. Loosen the cap, then finish removing the cap/nozzle assembly.

NOTE: AVK hydrants manufactured after 2004 have a "fifth lug" located at the 6 o'clock position in the outlets. This prevents the nozzles from being installed with the slotted lug in the wrong location.

6. Using a pointed punch and a hammer, stamp a small dimple into the surface of the nozzles as shown in figures "6F & 6J". The small dimple must be located on the center line of the "split" lug on the bronze nozzles.
7. Mark the dimples with a permanent ink marker to make the marks easily visible.
8. Follow the steps in "REASSEMBLY AFTER INSPECTION", to reinstall the nozzles and caps.

INSPECTION

NOZZLE DISASSEMBLY FOR INSPECTION (continued):

WARNING: For all of the following repair procedures, the hydrant must be isolated or the system depressurized and drained before removing the hydrant components. Failure to do so may cause pressure to be released resulting in severe injury or death.

Nozzle leaking from around the Nozzle Cap:

1. Remove the Hose Nozzle Cap (F19), or Pumper Nozzle Cap (F28), using an AVK Hydrant Wrench or adjustable hydrant wrench.
2. Remove and replace the Hose Nozzle Cap Gasket (F22), or Pumper Nozzle Cap Gasket (F27), and replace the cap and gasket assembly.

Nozzle leaking from around the Nozzle O-ring area:

1. Remove the Nozzle Retaining Screws (F23) using a 3/16" or 5mm Allen wrench.
2. Rotate the nozzle in a clockwise direction approximately 40 degrees until the nozzle slot aligns with lug opening on the nozzle section, located at the 6 o'clock position of the desired outlet. See Fig. "6F".
3. Pull the cap/nozzle assembly outward until the nozzle lugs are between the nozzle section lugs as shown in Fig. "6C".
4. Loosen the cap, then finish removing the cap/nozzle assembly. (See Fig. 6E)
5. Remove the old Hose Nozzle O-ring (F22), or Pumper Nozzle O-ring (F25), and replace with a new one.
6. Lightly grease the o-ring with a food grade grease that contains no acetate or silicone.
7. Follow the steps in "REASSEMBLY AFTER INSPECTION", to reinstall the nozzles and caps.

NOZZLE REASSEMBLY AFTER INSPECTION:

1. Insert the greased Cap/Nozzle assembly into the nozzle section outlet until the nozzle lugs are in line with the nozzle section lugs as shown in Fig. 6C.
2. Tighten the cap on the nozzle. Insert the cap/nozzle assembly fully into the nozzle section and using a hydrant wrench, slowly rotate the cap/nozzle assembly counter clockwise, approximately 40 degrees, until the slotted nozzle lug aligns with the Nozzle Retaining Screw hole. This can be verified by lining up the dimple with the Nozzle Retaining Screw hole.
3. Apply a drop of thread-locker (Loctite #242 or equal) to the end of the retaining screws, and using a 3/16" or 5mm Allen wrench, tighten it until it just contacts the nozzle, do not back off the locking screws.
4. Verify that the Cap has been secured.
5. Once the hydrant has been completely reassembled, turn on the supply valve and slowly open the hydrant to check for leaks.

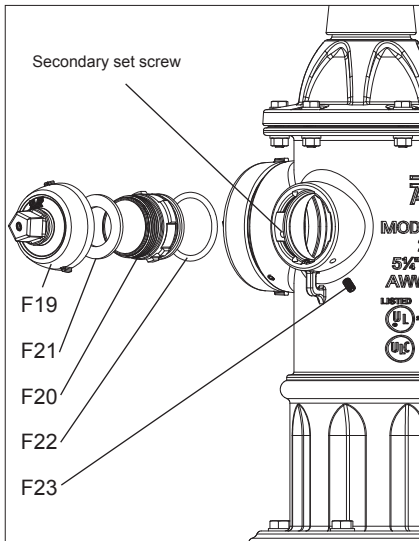

Fig. 6A

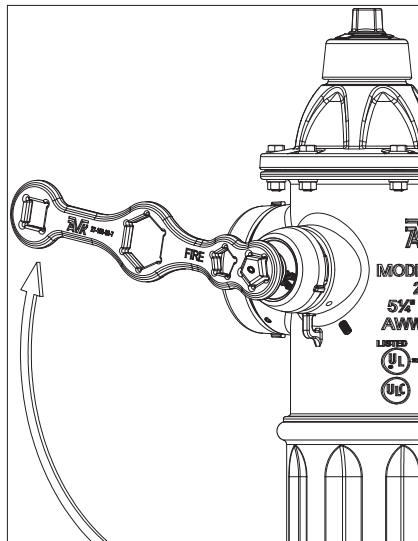

Fig. 6B

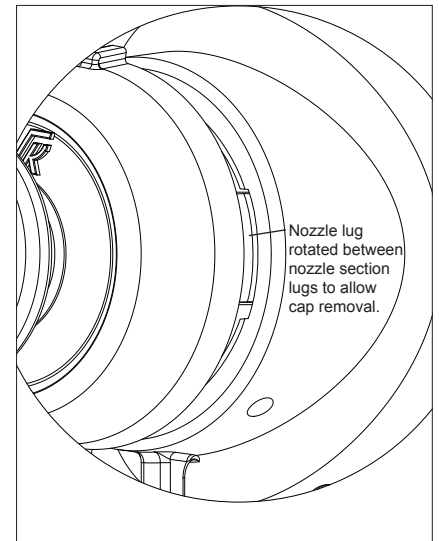

Fig. 6C

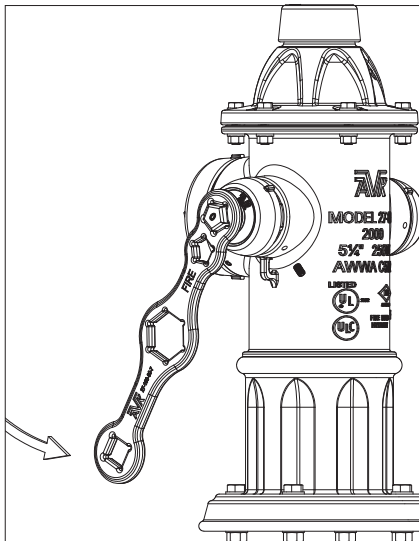

Fig. 6D

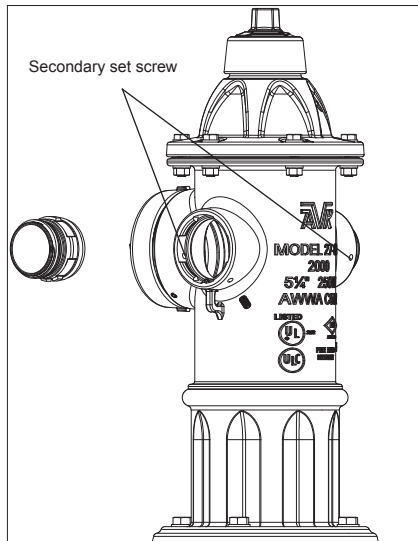

Fig. 6E

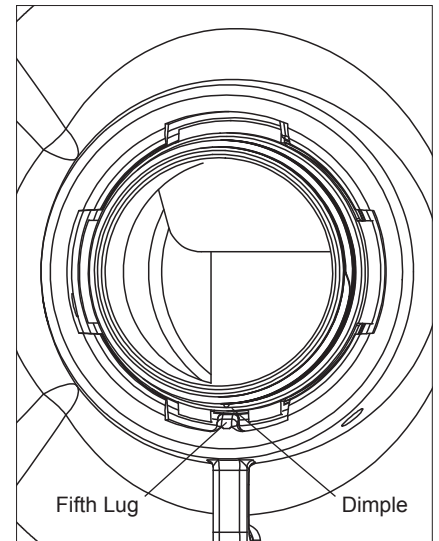

Fig. 6F

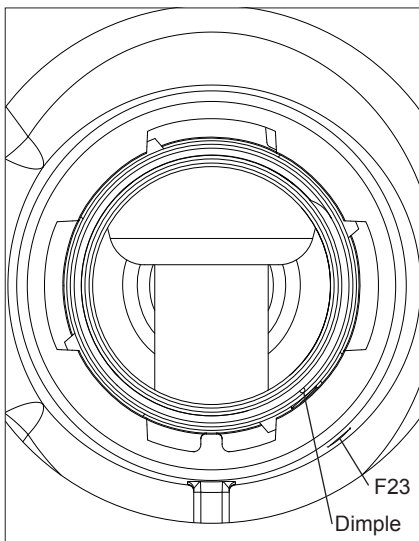

Fig. 6G

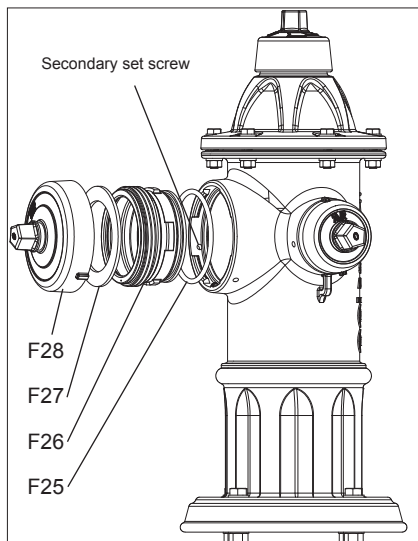

Fig. 6H
page 12

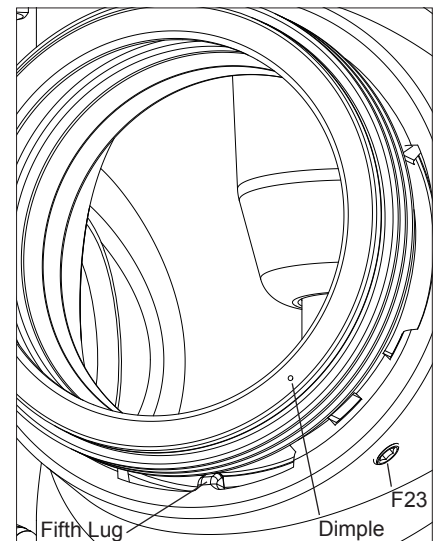

Fig. 6J

DISASSEMBLY FOR INSPECTION: (continued)

MAIN VALVE INSPECTION

WARNING: For all of the following repair procedures, the hydrant must be isolated or the system depressurized and drained before removing the hydrant components. Failure to do so may cause pressure to be released resulting in severe injury or death.

AVK Hydrants are designed to allow all internal components to be easily removed without displacing installation.

WARNING: On a partially disassembled hydrant under line pressure, pressing down on the stem could force open the Main Valve (F61) and allow it to slam shut, creating a water hammer. If the intention is to remove the Main Valve (F61) first locate and be sure the supply valve is closed. Relieve the pressure on the Main Valve (F61) by momentarily opening and then closing the hydrant. Reopen the supply valve after the hydrant has been reassembled.

1. Remove the Weathershield Bolt (F1) with a 5/16", (8mm) hexagon key. Lift off the Weathershield (F2). (See Fig. 7A)
2. Remove the Lock Plate Screw (F3) and Lock Plate (F4) with a 5/32" or (4mm), hexagon key.
3. Using the AVK operating wrench, or a large adjustable wrench, unscrew the Thrust Nut (F6) counterclockwise. (See Fig. 7A & 7B)
4. Remove the Operating Nut (F10) using the AVK operating wrench. Turn counterclockwise for "Open Left Hydrants", and clockwise for "Open Right", hydrants. Remove the Anti Friction Washers (F8), and set aside with the Operating Nut. (See Fig. 7C)
5. Remove the Stop Nut (F11) with the deep socket located at the end of the AVK seat wrench. CAUTION: Do not overtighten the Stop Nut (F11), during re-assembly! (See Fig. 7D)
6. Remove the six Bonnet Bolts (F12) and associated hardware using 3/4" or 19mm wrenches. Lift Bonnet (F14) over the Upper Stem Rod (F16) and set aside.

NOTE: On oil filled hydrants, to avoid draining of oil from the oil reservoir in the bonnet (F14), press the Oilsaver sleeve (See Fig. 7E and 7F), with the stop ring placed downward) over the Upper Stem Rod (F16) during the disassembly. While holding the Oilsaver in place, lift the Bonnet (F14), and Oilsaver off of the Upper Stem Rod (F16). During reassembly inspect the Stem Seal O-rings (F15) and the Barrel Gasket (F17) for damage.

7. To remove the Valve Seat Ring (F51) and Main Valve Assembly, Slide the AVK Seat Wrench (Fig. 7G) over the Upper Stem Rod (F16) and engage the seat removal pin. Turn the tool counterclockwise, (approximately 6 turns) until the Valve Seat Ring has disengaged from the Drain Ring (F54).

NOTE: For deeper buries, and optional AVK Seat Wrench Alignment Tool is available. (See Fig. 7G)

8. Remove tool and set aside. Lift and remove the Upper Stem Rod / Lower Stem Rod and Main Valve Assembly from the Lower Barrel (F49). (See Fig. 7H)
9. Inspect the Main Valve (F61), Valve Seat Ring (F51), Valve Seat O-rings (F53) for damage. Replace if necessary.
10. If any of the above parts are to be replaced, clamp the Lower Stem Rod (F41) in a standard pipe vise. (See Fig. 7J) Slide the Valve Seat Ring (F51) off the ears of the Main Valve. To disconnect the Main Valve from the Lower Stem Rod (F41) remove the Spring Pin (F38), and Main Valve Retaining Pin Washer (F88), from the Main Valve Retaining Pin (F60). Reverse the steps for reassembly. Lightly grease the Main Valve ears and Main Valve O-rings (F53), with a food grade grease that contains no acetate or silicone.

REASSEMBLY AFTER INSPECTION:

MAIN VALVE REASSEMBLY

CAUTION: Take care not to cross thread the Seat Ring (F51), during reassembly.

1. Using the AVK Seat Wrench, re-install the Main Valve and Stem assembly. Using the seat wrench, rotate the main valve and stem assembly counter clockwise until you feel a slight drop. Then tighten clockwise until the Main Valve/Stem assembly is completely tightened. Take care not to over tighten the assembly!
2. Verify that the Barrel Gasket (F17), is in place on top of the Nozzle Section. (See Fig. 7F) Carefully slide the Bonnet (F14), over the Upper Stem Rod (F16), taking care not to dislodge the Stem Seal O-rings (F15), or Barrel Gasket. Carefully rotate the bonnet until the grease zerk or oil, brass plug is in the desired positioning.
3. Install the Bonnet Bolts, Washers, and Nuts finger tight.
4. Using the AVK Seat Wrench, install the Stop Nut (F11). Do not over tighten the Stop Nut!
5. If required, fill the lubrication reservoir with the appropriate food grade oil or grease that contains no acetate or silicone.
6. Place one Anti Friction Washer (F8), on the top and bottom of the Operating Nut (F10) thrust collar. (See Fig. 7A)
7. Install the Operating Nut and Anti Friction Washers. Tighten the operating nut until the thrust collar just snugs up against the hydrant bonnet.
8. Lightly grease the o-rings on the Thrust Nut (F6), and screw the Thrust Nut into the Bonnet completely, then back off the Thrust Nut 1/8 to 1/4 turn, until the Thrust Nut lines up with the Lockplate (F4).
9. Install the Lockplate and secure it with the Lockplate Screw (F3), using a 7/64" or (3mm), hexagon key.
10. Tighten the Bonnet Bolts/Nuts to 65 Ft. Lbs..
11. Install the Weathershield and Weathershield Bolt using a 5/16", (8mm) hexagon key.
12. After reassembly is complete, open the supply valve and test the hydrant for leaks.

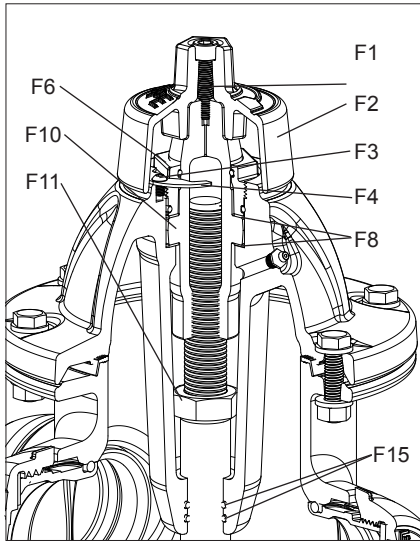

Fig. 7A

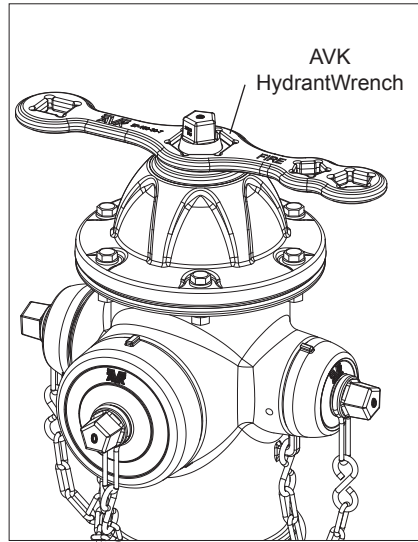

Fig. 7B

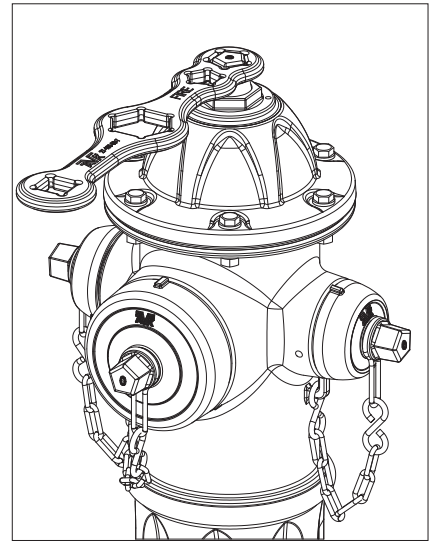

Fig. 7C

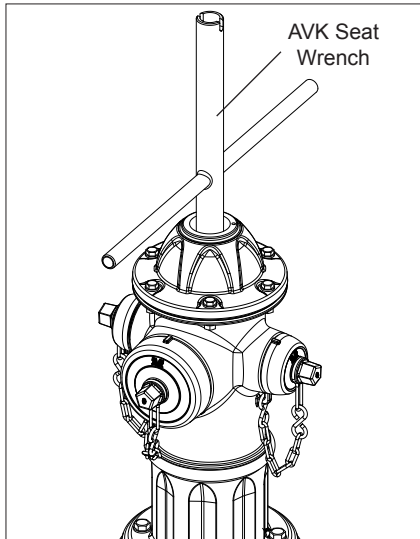

Fig. 7D

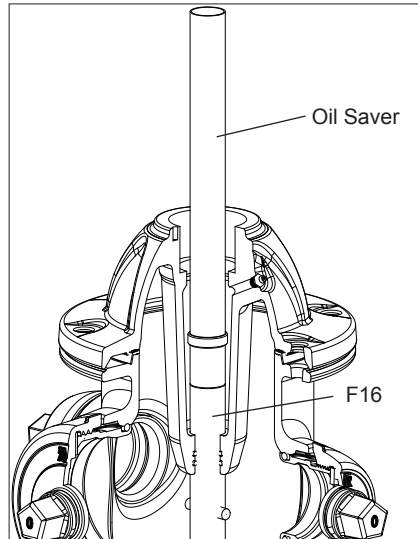

Fig. 7E

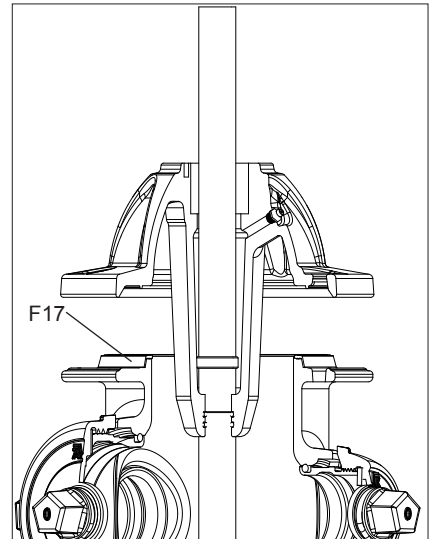

Fig. 7F

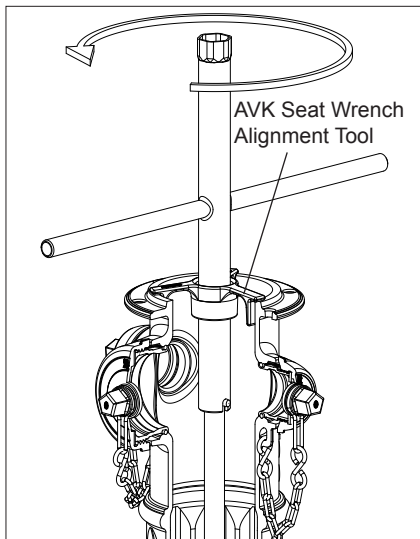

Fig. 7G

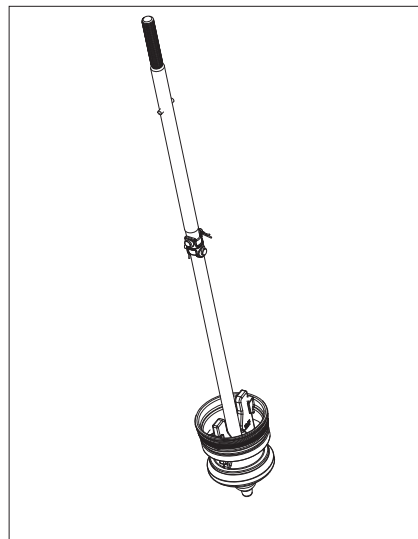

Fig. 7H

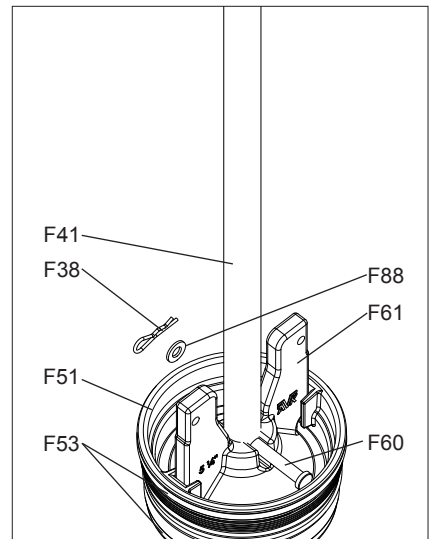

Fig. 7J

REPAIR PROCEDURES

TRAFFIC REPAIR:

WARNING: For all of the following repair procedures, the hydrant must be isolated or the system depressurized and drained before removing the hydrant components. Failure to do so may cause pressure to be released resulting in severe injury or death.

AVK Dry Barrel Hydrants feature a safety Breakable Flange (F33) and Breakable Stem Rod Coupling (F37) design. This allows the hydrant head assembly to be struck by a vehicle and “Break Away” reducing the impact to the water main. In the event the hydrant head assembly has been broken away, the following repairs will be necessary.

WARNING: On a partially disassembled hydrant under line pressure, pressing down on the stem could force open the Main Valve (F61) and allow it to slam shut, creating a water hammer. In the event of a vehicle collision or break away, locate and be sure the supply valve is closed. After reassembly, relieve the pressure on the Main Valve (F61) by momentarily opening and then closing the hydrant. Reopen the supply valve after the hydrant has been reassembled.

1. Remove the hardware (F30,31,34) from the Breakable Flange (F33). Slide the Lock Ring (F32) off of the Lower Barrel (F49). (See Fig. 8)
2. Remove the Spring Pins (F38) from the Coupler Pins (F36) in the Upper Stem Rod (F16) and Lower Stem Rod (F41). Remove and discard the broken Breakable Coupling (F37).
3. If required, remove the Upper Stem Rod (F16) from the hydrant head assembly by following the Warnings and steps 1 through 4 in the MAIN VALVE INSPECTION section on page 14.
4. Re-connect the Upper Stem Rod (F16) to the Lower Stem Rod (F41) with new Coupler Pins (F36), new Breakable Stem Rod Coupling (F37), and secure with Spring Pins (F38).

NOTE:For hydrants manufactured prior to Sept. 7, 2010, the Breakable Stem Rod Coupling should be replaced with the arrow pointing up. For hydrants manufactured after Sept. 7, 2010, there is no orientation. (See Fig. 9)

5. Slide a new Breakable Flange (F33) over the Lower Barrel (F49), then install a new Lock Ring (F32) into the groove on the Lower Barrel..

WARNING: Be sure the Breakable Flange(F33) is right side up, indicated with the text "This Side Up", facing towards the nozzle section. (See Fig.8&9) .

6. Clean the hydrant's Nozzle Section/Upper Barrel and Lower Barrel flange face and install a new Barrel Gasket (F17).

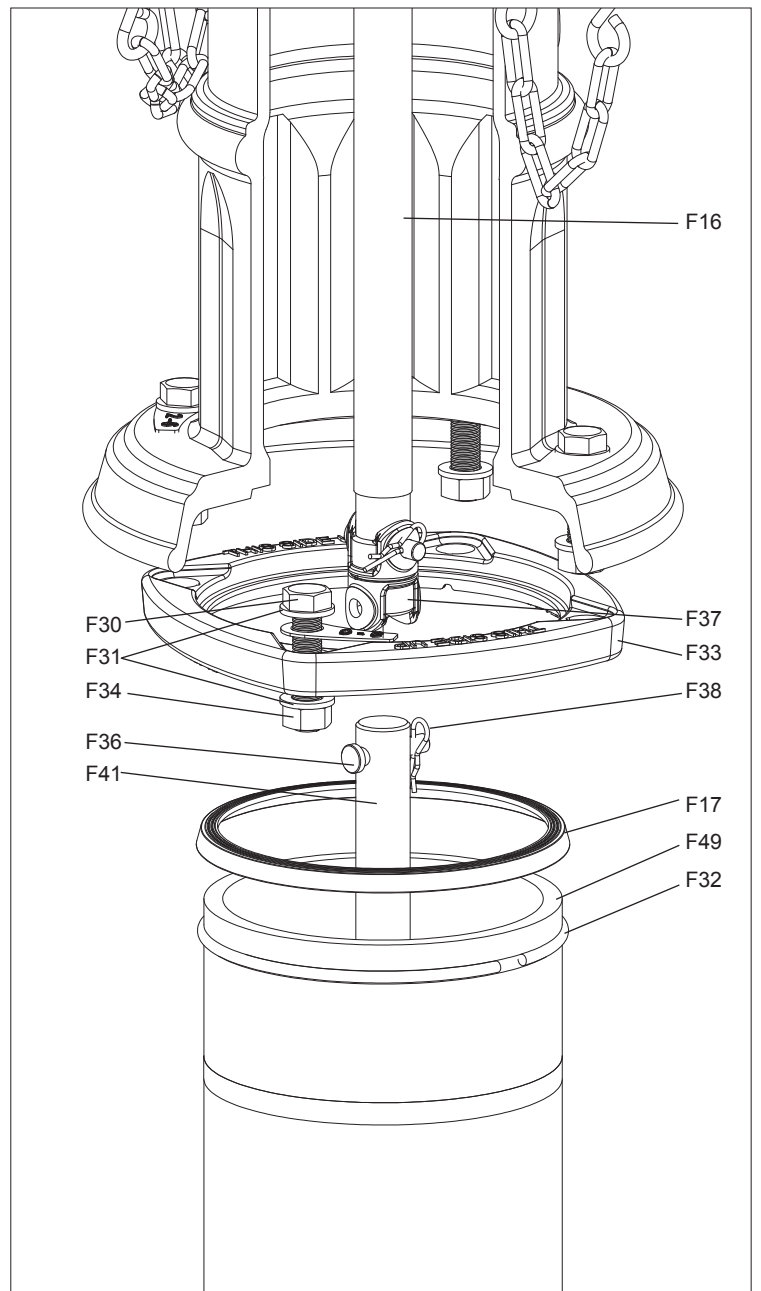

Fig. 8
Traffic Repair

REPAIR PROCEDURES

TRAFFIC REPAIR: (continued)

7. Lift the hydrant nozzle section assembly (F29) over the Upper Stem Rod (F16) and carefully place the assembly on the Lower Barrel and Barrel Gasket (F17). Check for correct alignment of the Barrel Gasket (F17) and re-install the nozzle section mounting hardware. Torque the mounting hardware (F30,F31,F34) to 80 foot pounds.
8. Verify that the Barrel Gasket (F17), is in place on top of the Nozzle Section. (See Fig. 7F) Carefully slide the Bonnet (F14), over the Upper Stem Rod (F16), taking care not to dislodge the Stem Seal O-rings (F15), or Barrel Gasket (F17).
9. Install the Bonnet Bolts, Washers, and Nuts Finger tight.
10. Using the AVK Seat Wrench, install the Stop Nut (F11). Do not over tighten the Stop Nut! Fill the lubrication reservoir with the appropriate food grade oil or grease that contains no acetate or silicone.
11. Place one Anti Friction Washer (F8), on the top and bottom of the Operating Nut (F10) thrust collar. (See Fig. 7A)
12. Install the Operating Nut and Anti Friction Washers.
13. Lightly grease the o-rings on the Thrust Nut (F6), and screw the Thrust Nut into the Bonnet completely, then back off the Thrust Nut 1/8 to 1/4 turn, until the Thrust Nut lines up with the Lockplate (F4).
14. Install the Lockplate and secure it with the Lockplate Screw (F3), using a 7/64" or (3mm), hexagon key.
15. Tighten the Bonnet Bolts/Nuts to 65 Ft. Lbs.
16. Install the Weathershield and Weathershield Bolt using a 5/16",(8mm) hexagon key.
17. After reassembly is complete, open the supply valve and test the hydrant for leaks.

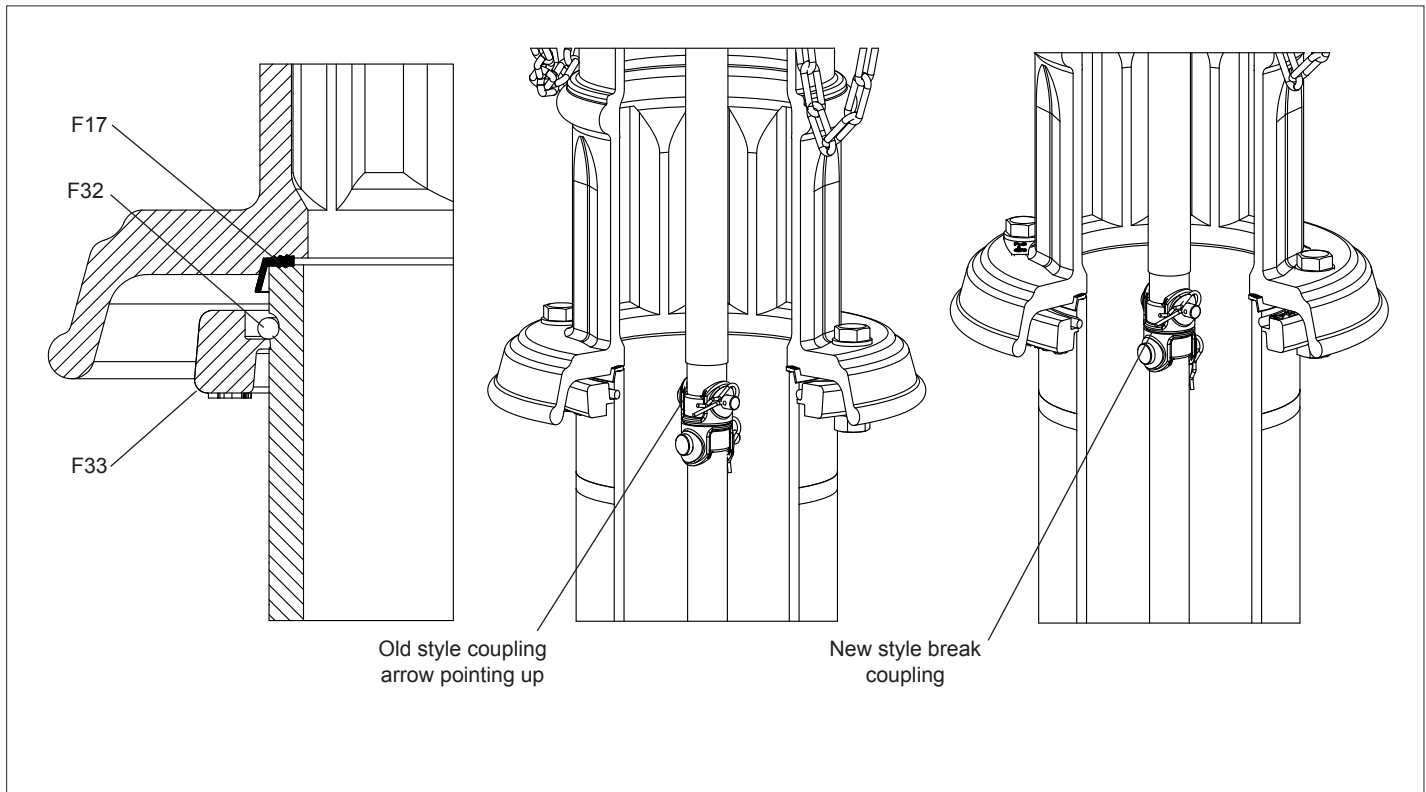

Fig. 9
Traffic Repair

OPTIONAL EQUIPMENT

EXTENSION KITS: Fig. 10

American AVK Hydrants have the capability of adjusting the Lower Barrel to the proper height due to changes in the finished grade. Extension Kits are available from 6" to 90" in 6" increments. (Longer upon request)

WARNING: On a partially disassembled hydrant under line pressure, pressing down on the stem could force open the Main Valve (F61) and allow it to slam shut, creating a water hammer. If the intention is to remove the Main Valve (F61) first locate and be sure the supply valve is closed. Relieve the pressure on the Main Valve (F61) by momentarily opening and then closing the hydrant.

NOTE: Only one extension kit of the proper size may be installed on a hydrant. Multiple extension kits on a single hydrant may impede hydrant operation. Only extension kits manufactured by AVK should be used on AVK fire hydrants. Non AVK extension kits may impede hydrant operation.

The installation is performed as follows:

1. Remove the Weathershield Retaining Bolt (F1) with an 5/16" or (8mm) hexagon key. Lift off the Weathershield (F2).
2. Remove the Lock Plate Retaining Screw (F3) and Lock Plate (F4) with a 7/64" or (3mm) hexagon key. Note: Older hydrants may be equipped with a set screw instead of lock plate. Remove the set screw and set aside for later use.
3. Remove the Thrust Nut (F6) using the AVK operating wrench and rotating counter clockwise. Remove the upper Anti Friction Washer (F8).
4. Remove the Operating Nut (F10) using the AVK operating wrench. Turn counterclockwise for "Open Left Hydrants", and clockwise for "Open Right Hydrants". Remove the lower Anti Friction Washer (F8) and set aside with the operating nut.
5. Using the socket wrench end of the AVK T-wrench, remove the Stop Nut (F11) from the Upper Stem Rod (F16).
6. Remove the six Bonnet Bolts (F12), Nuts (F18), and Washers (F13), using a 3/4" or (19mm) wrench. Lift Bonnet (F14) straight up over the Upper Stem Rod (F16), carefully to avoid damage to the Stem Seal O-rings (F15).
7. Remove the Barrel Gasket (F17), and inspect it for damage. If damaged, replace.
8. Remove the four Nozzle Section Bolts (F30), Nuts (F34), and Washers (F31), using 15/16", or 24mm wrenches. Carefully lift the Nozzle Section (F29) off of the lower assembly.

NOTE: For series 27 dry barrel hydrants manufactured after Feb. 18, 2011, hydrants with buries from 3' to 7' include Hydrant Bury Tags (F94).

9. Remove the lower Spring Pin (F38) and slide the lower Coupler Pin (F36) from the Lower Stem Rod (F41). Disconnect the Upper Stem Rod (F16) along with the Stem Rod Coupling (F37) from the Lower Stem Rod (F41). Inspect the Stem Rod Coupling for damage and replace if necessary.
10. Remove the Breakable Flange (F33), and Lock Ring (F32). Set aside for later re-assembly.
11. Install a Standpipe Flange (F46) from the Extension Kit and reinstall the Lock Ring (F32).
NOTE: Ensure the Standpipe Flange is oriented correctly with the recessed side towards the Lock Rings.
12. ~~Slide the Spider (F39) down over the Extension Stem Rod (F48) and align the Spider Retaining Bolt (F40) with the prepared hole. Tighten the Spider Retaining Bolt with a 11/16" or (17mm) wrench. Do not over tighten. As of Nov. 1, 2011, the Spider and Spider Bolt are no longer required on AVK dry barrel hydrants.~~
13. Install the Extension Stem Rod (F48) on the Lower Stem Rod (F41) with new Spring Pin (F38), Coupler Pin (F36) and Stem Rod Coupling (F37).
14. Clean the top of the Lower Barrel (F49) and install a Barrel Gasket (F17).
15. If not already done, install a Lock Ring (F32) onto the lower groove of the Extension Barrel (F43). The top of the Extension Barrel is marked with a Bury Line.
16. Place the Extension Barrel (F43) onto the Lower Barrel (F49), making sure that the Barrel Gasket (F17) stays in place. Slide the Standpipe Flanges (F46) until rest against the Lock Rings (F32).
17. Align the bolt holes on the two Standpipe Flanges (F46) and install the Extension Barrel Bolts (F44), Nuts (F34) and Washers (F31) as shown in Figure 10 and "Detail E". Tighten to 80 Ft. Lbs..
18. Slide the Breakable Flange (F33) onto the Extension Barrel (F43). NOTE: The Breakable Flange must be installed so that the wording "THIS SIDE UP" cast on the Breakable Flange are facing up.
19. Reinstall the Lock Ring (F32) onto the Extension Barrel (F43).
20. **NOTE: (The following procedure is for hydrants manufactured prior to Sept. 7, 2010.)** Connect Upper Stem Rod (F16) to Extension Stem Rod (F48) with Spring Pin (F38) and Coupler Pin (F36) and Stem Rod Coupling (F37). Position the groove of the Stem Rod Coupling (F37) on the bottom, arrow pointing up. (See "Detail B")
21. For hydrants manufactured after Sept. 7, 2010, the new style stem rod coupling is used and there is no orientation requirement. (See "Detail C")
22. Clean the top of the Extension Barrel (F43) and place a new Barrel Gasket (F17) on top.
23. Carefully place the Nozzle Section (F29) on top of the Extension Barrel (F43) so that the Barrel Gasket (F17) is not moved or damaged.

OPTIONAL EQUIPMENT

EXTENSION KITS: Fig. 10 (continued):

24. Slide the Breakable Flange (F33), with the text "THIS SIDE UP" against the Lock Ring (F32), (See "Detail D") and align with the holes in the Nozzles Section (F29). Reinstall the Bolts, Nuts, and Washers removed in step 8.
NOTE: For series 27 dry barrel hydrants manufactured after Feb. 18, 2011, hydrants with buries from 3' to 7' include Hydrant Bury Tags (F94). Extension Kits up to 4' also include an Extension Bury Tag (F95). (See "Detail A") for installation locations. Tighten just hand tight. Carefully rotate the Nozzle Section with nozzles in the desired position. Tighten to 80 Ft. Lbs..
25. Clean the top of the Nozzle Section (F29) and place a new barrel gasket (F17) on top.
26. Clean the top of the Nozzle Section (F29) and place a new Barrel Gasket (F17) on top.
27. Carefully slide the Bonnet (F14) over the Upper Stem Rod (F16) and onto the Nozzle Section (F29). Take care not to displace the Stem Seal O-rings (F15). Rotate to place grease zerk or oil plug to a location convenient for future maintenance. Be careful that the Barrel Gasket (F17) stays in its proper position.
28. Install the Bonnet Bolts (F12), Nuts (F18), and Washers (F13) and tighten finger tight.
29. Using the socket portion of the AVK T-wrench, reinstall the Stop Nut (F11). Spin the stop nut down until it stops, and then snug it about 1/4 turn tighter.
30. Reinstall the Anti Friction Washer (F8) in the oil reservoir of the Bonnet (F14).
31. If required, refill the lubrication reservoir in the Bonnet (F14) reservoir with a food grade oil or grease that contains no acetate or silicone.
32. Reinstall the Operating Nut (F10) . Tighten the Operating Nut all the way until it is snug against the lower Anti Friction Washer.
33. Reinstall the Anti Friction Washer (F8) on top of the Operating Nut (F10).
34. Lightly grease the Thrust Nut O-rings (F5&F7), and reinstall the Thrust Nut (F6). Tighten the Thrust Nut until it is just snug against the Anti Friction Washer (F8), then back off the Thrust Nut 1/8 to 1/4 to the first location at which the Lock Plate (F4) can be installed. **NOTE: DO NOT OVER TIGHTEN THE THRUST NUT (F6).**
35. Reinstall the Lock Plate (F4) and Lock Plate Screw (F3). On hydrants with equipped with a set screw, back off the thrust nut until the set screw can be reinstalled.
36. Tighten the Bonnet Bolts (F12) to 65 Ft. Lbs., using a star pattern.
37. Reinstall the Weathershield (F2) and Weathershield Bolt (F1).
38. Operate the hydrant into the fully open position and then close it fully prior to turning the lead valve on to allow the oil or grease to lubricate the operating nut.
39. Turn on the lead valve and operate the hydrant.

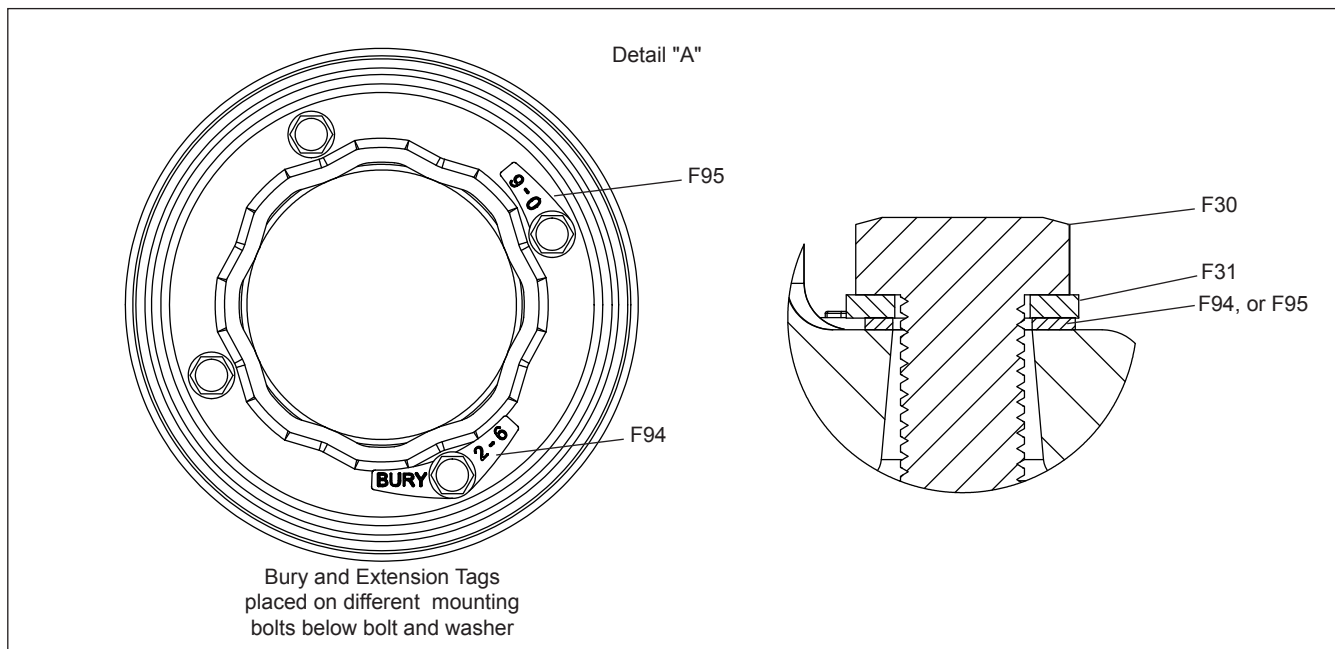

Detail "B"
For hydrants manufactured
prior to Sept. 7, 2010

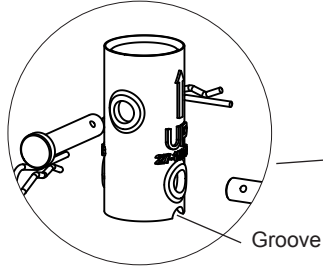

Detail "C"
For hydrants manufactured
after Sept. 7, 2010

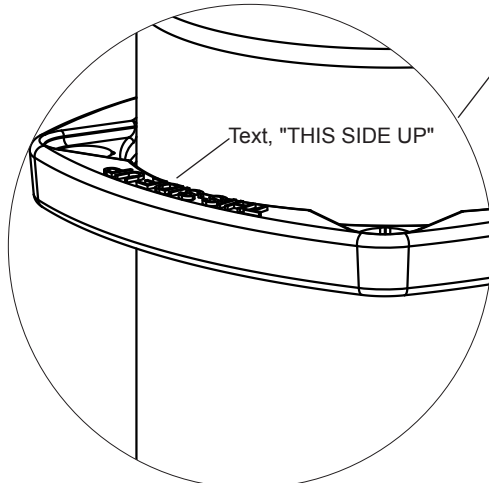
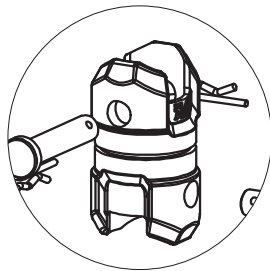

Detail "D"

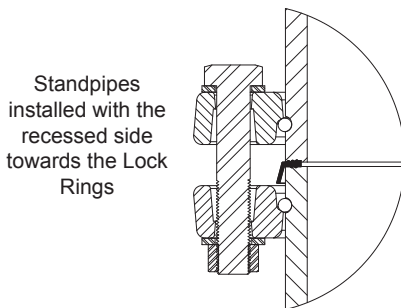

Detail "E"

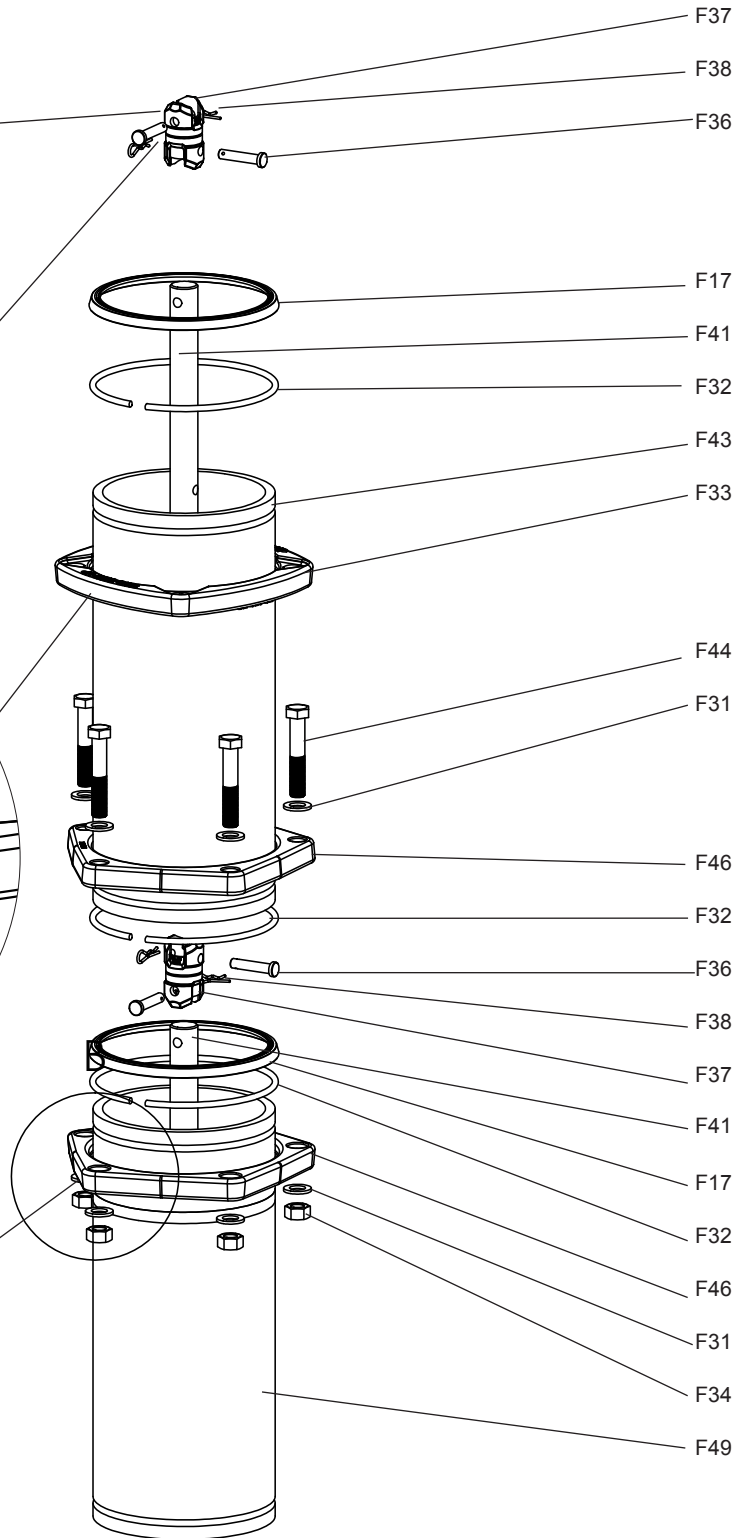

Fig. 10
Extension Kit

** As of Nov. 1, 2011, the Spider and Spider Bolt are no longer required in AVK dry barrel hydrants

OPTIONAL EQUIPMENT

TAMPERGUARD WEATHERSHIELD:

The American AVK Series 27/47X Tamper Resistant Weathershield Kit consists of one Tamper Resistant Weather Shield (F93), one Tamper Resistant Lockplate (F94), and one Tamper Resistant Lockplate Screw (F95). A Lock with Key (F97) and Lock Pin (F96) are optional.

1. Remove old Weathershield by removing Weathershield Bolt (F1) with a 5/16", or 8mm hex key.
2. Remove old Lockplate (F4) by removing Lockplate Screw (F3) with a 5/32", or 4mm hex key.
3. Install the new Tamper Resistant Lockplate (F94) using the high strength Lockplat Screw supplied in the kit (F95), with a 5mm hex key. NOTE: The high strength screw must be used to increase the strength of the entire assembly.
4. Install new Tamper Resistant Weathershield (F93) using the Weathershield Bolt (F1).
5. Align the holes in Tamper Resistant Weathershield (F93) and Tamper Resistant Lock Plate (F94). Note: When the hydrant is closed completely, the weather shield can rotate a minimum of one complete rotation before main valve is engaged.
6. Insert Lock Pin (F96) and Lock (F97).

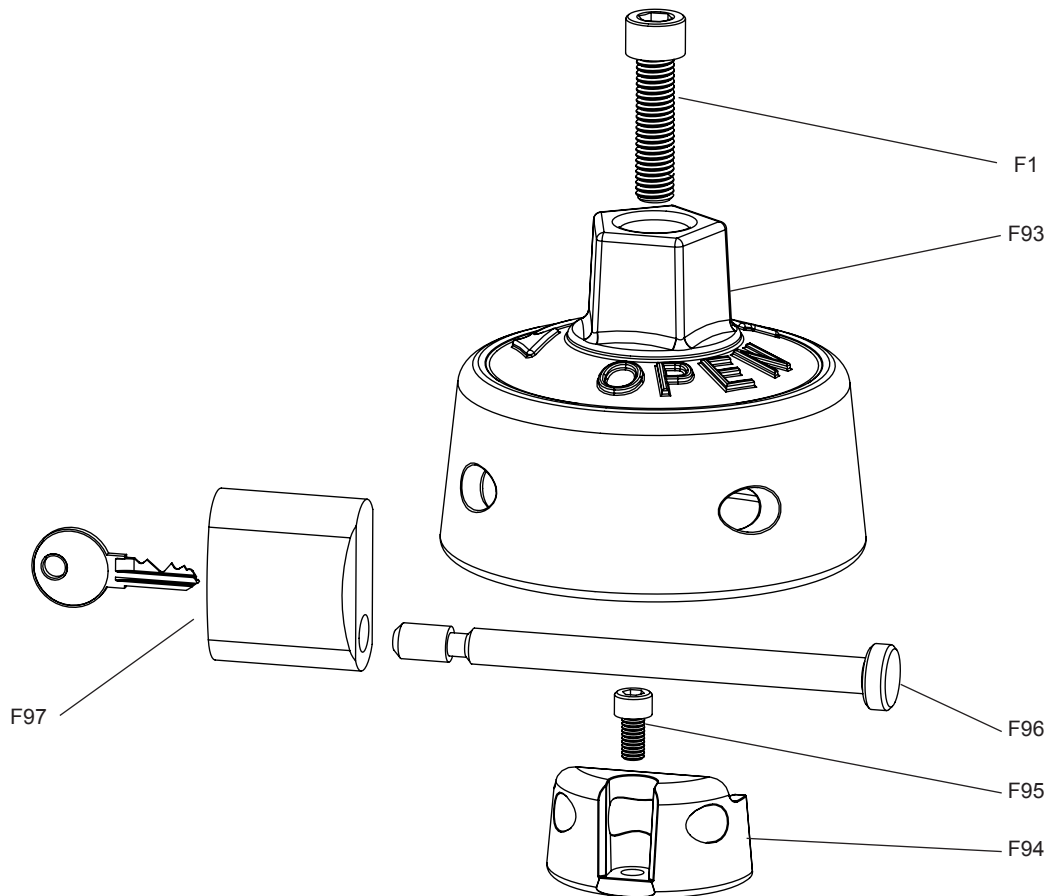

Fig. 11
TamperGuard Weathershield
Kit

OPTIONAL EQUIPMENT

THRUST BEARING ASSEMBLY:

WARNING: For all of the following repair procedures, the hydrant must be isolated or the system depressurized and drained before removing the hydrant components. Failure to do so may cause pressure to be released resulting in severe injury or death.

NOTE: As of December 2018, the 3 piece Thrust Bearing Assembly is the standard configuration supplied from the factory.

When upgrading pre-existing installations, remove the old Operating Nut, and Anti Friction Washers and replace with the following components.

1. Remove the Weathershield Bolt (F1), and Weathershield (F2) using a 5/16" (8mm) hexagon key.
2. Remove the Lockplate Screw (F3) and Lockplate (F4) using a 3/16" hexagon key.
3. Use an AVK Hydrant Wrench or adjustable wrench to remove the Thrust Nut (F6) and it's o-rings, (F5) Inner Thrust Nut O-ring, (F7) Outer Thrust Nut O-ring. Check o-rings for damage and replace if necessary.
4. Once the old Operating Nut and Anti Friction Washers have been discarded, verify that the Stop Nut (F11) is secure at the bottom of the threads of the Upper Stem Rod (F16). Use the AVK T-Wrench to ensure that the Stop Nut is not backed off.
5. Replace them with the new Operating Nut (F10), and one Anti Friction Washer (F8), placed below the Operating Nut shoulder.
6. Install the Lubrication Hole Seal (F9), into the threaded hole in the top of the Operating Nut (F10).
7. Install the Thrust Bearing Races, (F69), and Thrust Bearing (F70), as shown in Fig. 12.
8. Lightly grease the Thrust Nut O-rings (F5&F7), and reinstall the Thrust Nut (F6). Tighten the Thrust Nut until it is just snug against the Anti Friction Washer (F8), then back off the Thrust Nut 1/8 to 1/4 to the first location at which the Lock Plate (F4) can be installed. **NOTE: DO NOT OVER TIGHTEN THE THRUST NUT (F6).**
9. Reinstall the Lock Plate (F4) and Lock Plate Screw (F3). On hydrants with equipped with a set screw, back off the thrust nut until the set screw can be reinstalled.
10. Service the hydrant with a food grade grease or oil that contains no acetate or silicone

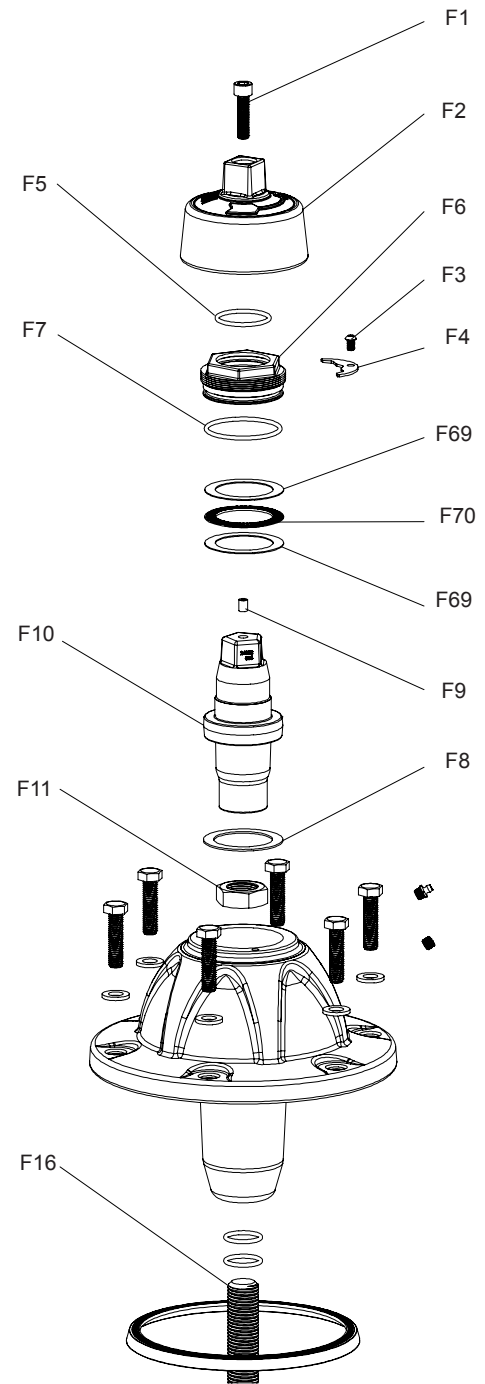

Fig. 12
Thrust Bearing Components

TROUBLESHOOTING GUIDE

WARNING: The fire hydrant must be isolated before performing any maintenance. Failure to do so may cause pressure to be released resulting in severe injury or death.

Several problems and solutions are presented below to assist you in troubleshooting the hydrant.

PROBLEM: Hydrant slams shut while closing.

Probable Cause: Play in Stem Rod assembly due to wear in Stem Rod Couplings.

Corrective action: Inspect Breakable Coupling and Extension Coupling (if present) for wear and replace if necessary.

PROBLEM: Hydrant hard to operate.

Probable Cause: Operating Nut/ Thrust Nut assembly too tight.

Corrective action: Remove the Weathershield to access the Lockplate and remove the Lockplate. Tighten the Thrust Nut completely into the Nozzle section then back off 1/8 to 1/4 turn until the Thrust Nut aligns with the first available notch in the Lockplate. Re-install the Lockplate and Weathershield.

Probable Cause: Operating Nut not lubricated.

Corrective action: Disassemble the Operating Nut/Thrust Nut assembly. Clean and re-lubricate using a food grade grease.

PROBLEM: Nozzle facing the wrong direction.

Corrective action: Loosen the Nozzle Section hardware and carefully rotate the Nozzle Section to the desired position. Tighten the mounting hardware to 80 Ft. Lbs..

PROBLEM: Hydrant opens but will not close.

Probable Cause: The Breakable Coupling or Extension Coupling has broken or become disconnected.

Corrective action: Remove the Nozzle Section and replace the affected Coupling.

Probable Cause: Stem Rod assembly has been over torqued, broken, or become disconnected from Main Valve.

Corrective Action: Contact American AVK Sales Representative for further troubleshooting and special tool requirements.

PROBLEM: Hydrant will not drain.

Probable Cause: Drain holes may be plugged or blocked.

Corrective action: Loosen the Hose Nozzle Cap and slowly open the hydrant until water escapes from the nozzle. **DO NOT STAND IN FRONT OF THE NOZZLE!** Tighten the cap and force flush the drains. If the hydrant continues not to drain, the hydrant may have to be excavated to verify that the drains have not been blocked by concrete support.

TROUBLESHOOTING GUIDE

PROBLEM: Hydrant flow is low.

Probable Cause: Hydrant or supply valve is not fully open.

Corrective action: Verify that the hydrant is fully open. The AVK Series 2780 hydrant main valve fully opens in approximately 19-21 turns.
Also locate and verify that the supply valve is fully open.

PROBLEM: Hydrant is leaking from a nozzle.

Probable Cause: Nozzle O-ring, or Cap Gasket is damaged.

Corrective action: Replace damaged O-ring or Gasket.

PROBLEM: Hydrant is leaking from the operating Nut.

Probable Cause: Stem Seal O-rings have failed.

Corrective action: Replace the Stem Seal O-rings and Thrust Nut O-rings if necessary. Refill hydrant with a food grade grease or oil that does not contain acetate or silicone.

PARTS AND SERVICE

For information on parts and service for your area contact American AVK. Make a note of the hydrant model number and size located on the hydrant and contact:

American AVK Company

2155 N. Meridian Blvd
Minden, NV 89423
PH: 775-552-1400
FAX: 775-783-7502
www.americanavk.com

**AMERICAN AVK COMPANY 10 YEAR WARRANTY
DRY BARREL FIRE HYDRANTS (S27XX)**

American AVK Company warrants all models of Series 2780 Dry Barrel Fire Hydrants to be free from defects in workmanship and materials for a period of ten (10) years from the date of shipment from American AVK Company. American AVK Company shall have no obligation under this warranty unless it is notified of claims hereunder promptly and in writing upon discovery thereof and within the warranty period, and unless the product is delivered to an American AVK Company facility within thirty (30) days of such notice.

American AVK shall have the right to inspect said product before it is removed from installation. If the product is removed from installation prior to approval from American AVK this warranty shall be void.

As to motors, gearing or accessory equipment purchased by American AVK Company from others manufacturers, and used or incorporated into American AVK Company's products, those manufacturers' warranties shall apply.

American AVK Company will honor all reasonable costs to repair or replace any American AVK Company Dry Barrel Fire Hydrant found to be defective.

American AVK Company's sole responsibility shall be, in its sole discretion, to replace the product with the same or a similar product, repair the product, or refund the price paid for the product provided the product has been properly applied and used under normal service and under conditions for which it is designed. American AVK Company shall not be liable for indirect, special, incidental, or consequential damage or penalties and does not assume any liability of purchase to others or to anyone for injury to persons or property.

THIS IS THE EXCLUSIVE WARRANTY GIVEN IN CONNECTION WITH THE SALE OF THIS PRODUCT. THERE ARE NO OTHER WARRANTIES, EXPRESSED OR IMPLIED, INCLUDING EXPRESSED OR IMPLIED WARRANTY OF MERCHANTABILITY, OR ANY EXPRESSED OR IMPLIED WARRANTY OF SUITABILITY FOR ANY PARTICULAR PURPOSE, GIVEN BY AMERICAN AVK COMPANY IN CONNECTION WITH THIS PRODUCT.

