

AVK DRY BARREL HYDRANTS

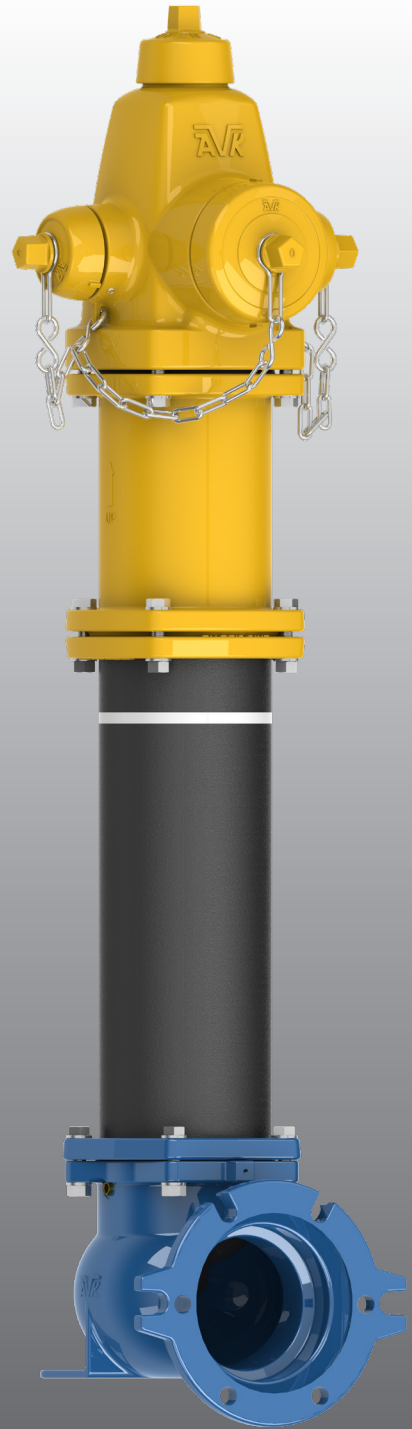
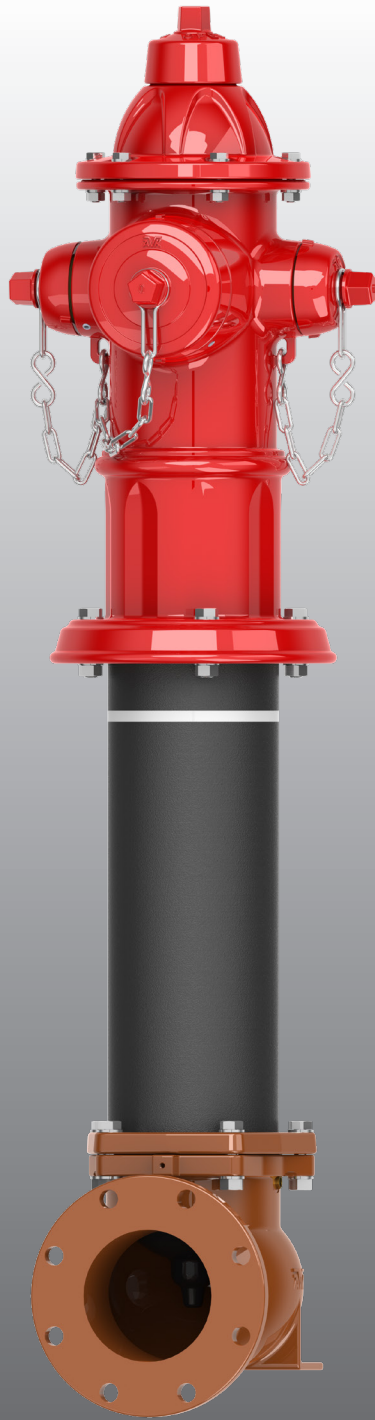

EXPECT
SUPERIOR
DESIGN

Ti SALES

36 Hudson Rd
Sudbury MA 01776



800-225-4616
www.tisales.com

AVR

AVK DRY BARREL HYDRANTS

FEATURES

- AVK dry barrel hydrants meet or exceed AWWA C502
- Modern or nostalgic styles available with interchangeable internal parts
- UL/ULC listed and FM approved
- Certified to NSF/ANSI 61, NSF/ANSI 372
- High pressure rating — 250 PSI
- High strength ductile iron nozzle section, barrel section, and base
- HDPE base connection available
- 5 ¼" valve opening for high flow rate
- Hydrant top repairable under pressure
- 360 degree nozzle section rotation
- Replaceable nozzles secured with external stainless steel lock screw
- Traffic flange designed for easy repair
- Stainless steel traffic coupling designed for longer operational life (resists elongation) and high corrosion resistance
- 360 degree, all bronze, drain channel; fast draining
- Inlet base can be changed without dismantling hydrant — available in most configurations (MJ, FL, PO, PE)
- Hydrant base and nozzle section are epoxy lined and coated
- Hydrant drain ports easily plugged, if required — may be plugged internally or externally
- Extensions available in lengths from 6" to 60"
- Stainless steel upper stem standard; lower stainless steel stem available
- 10 year warranty

AVK ANODE GROUNDING LUG

New anode grounding lug for corrosion prevention in corrosive soil environments

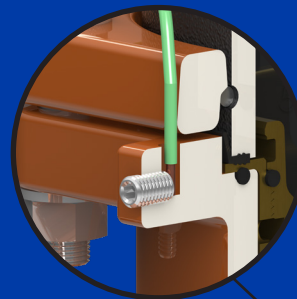

EXPECT A HYDRANT CONFIGURATION FOR YOUR APPLICATION



FUSIBLE HDPE BASE (NOSTALGIC & MODERN HYDRANT)

- Patented HDPE connection is water-tight and high strength — stronger than the pipe itself!
- Available in all common SDR ratings
- Pipe stub complies with AWWA C906

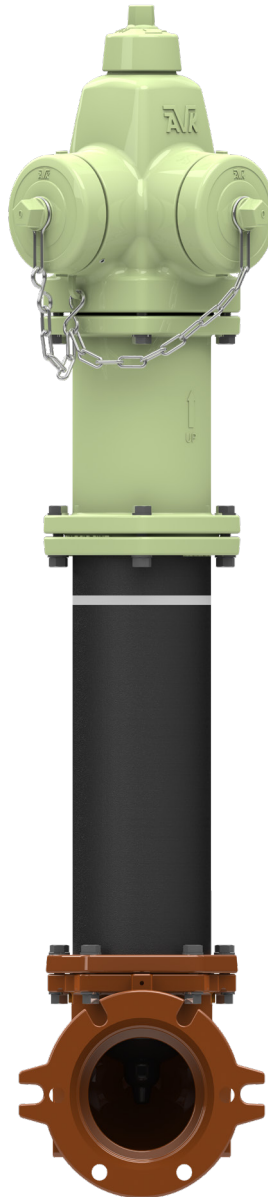

SINGLE & DUAL PUMPER OUTLETS (NOSTALGIC & MODERN HYDRANT)

- Dual pumper nozzles for maximum flow delivery
- Available in custom sizes and thread configurations, from 3½" to 5"
- Storz connections available

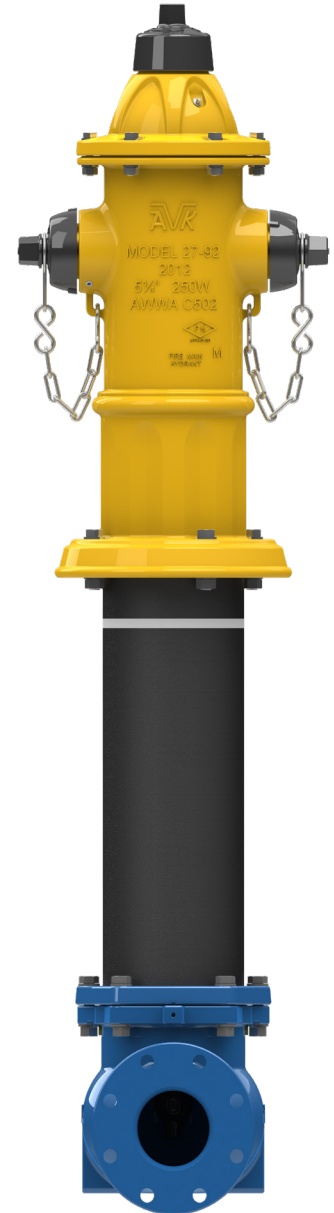

DUAL OUTLET NOZZLE HYDRANT (NOSTALGIC ONLY)

- For use in rural or low flow applications
- Available in custom 2½" hose outlet sizes and thread configurations

EXPECT TOTAL SAVINGS



POST/FLUSHING HYDRANT (SINGLE OUTLET)

- Traffic repair and extension kits available
- 2 1/4" Main valve opening
- Available in custom 2 1/2" hose outlet sizes and thread configurations

AVK FULLY ENCAPSULATED ONE-PIECE MAIN VALVE

- Patented AVK design — one piece replaces up to 13 pieces
- Ductile iron core fully encapsulated in EPDM rubber
- No exposed metal — completely corrosion resistant
- Easy maintenance
- Cost-effective, labor saving — reduced inventory
- UL/ULC listed and FM approved

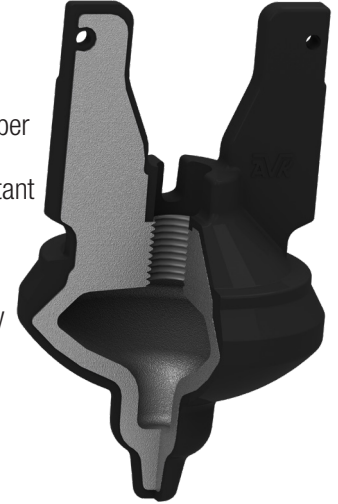

INCREASED DEPENDABILITY

- New 5 bolt below ground design for increased dependability and strength on extension kits and shoe assemblies.



MONITOR ELBOW (SERIES 2700 MODERN)

- 3" and 4" flanges available

ADDITIONAL PROTECTION

- The AVK TamperGuard lock is a simple and effective means of securing your hydrant against tampering, vandalism and water theft.

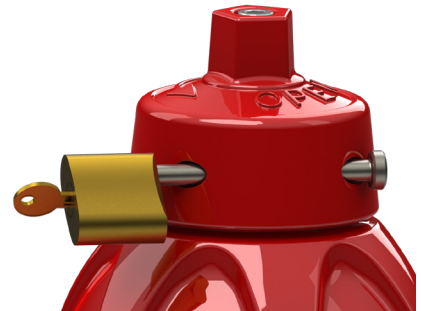

EVERY HYDRANT IS TRACEABLE

- Every AVK hydrant has a unique serial number engraved on the operating nut. This provides us complete traceability to the date the hydrant was built, and to every operation performed throughout our manufacturing process. AVK takes quality seriously, to provide a long-lasting hydrant and deliver total savings to you.



DRY BARREL HYDRANT SECURITY CHECK VALVE!

The AVK FlowGuard I™ prevents reverse flow through a fire hydrant, stopping intentional distribution system contamination or accidental cross connections. A clear waterway and free swinging disc ensure the valve does not interfere with fire-fighting operations; the check valve is designed for low head loss.

- Clear waterway design for low head-loss
- Can be installed on any 6" mechanical joint hydrant inlet
- EPDM disc for long life in chlorine and chloramines
- Stainless steel bolting to prevent corrosion
- Ductile iron body and bonnet, rated for 250 psi
- Fusion bonded epoxy coating
- Restrained joint between the fire hydrant and the check valve
- Resilient seated for a tight seal — even at low pressures
- Meets or exceeds AWWA C508
- Tested to 1,000,000 cycles
- 10 year warranty

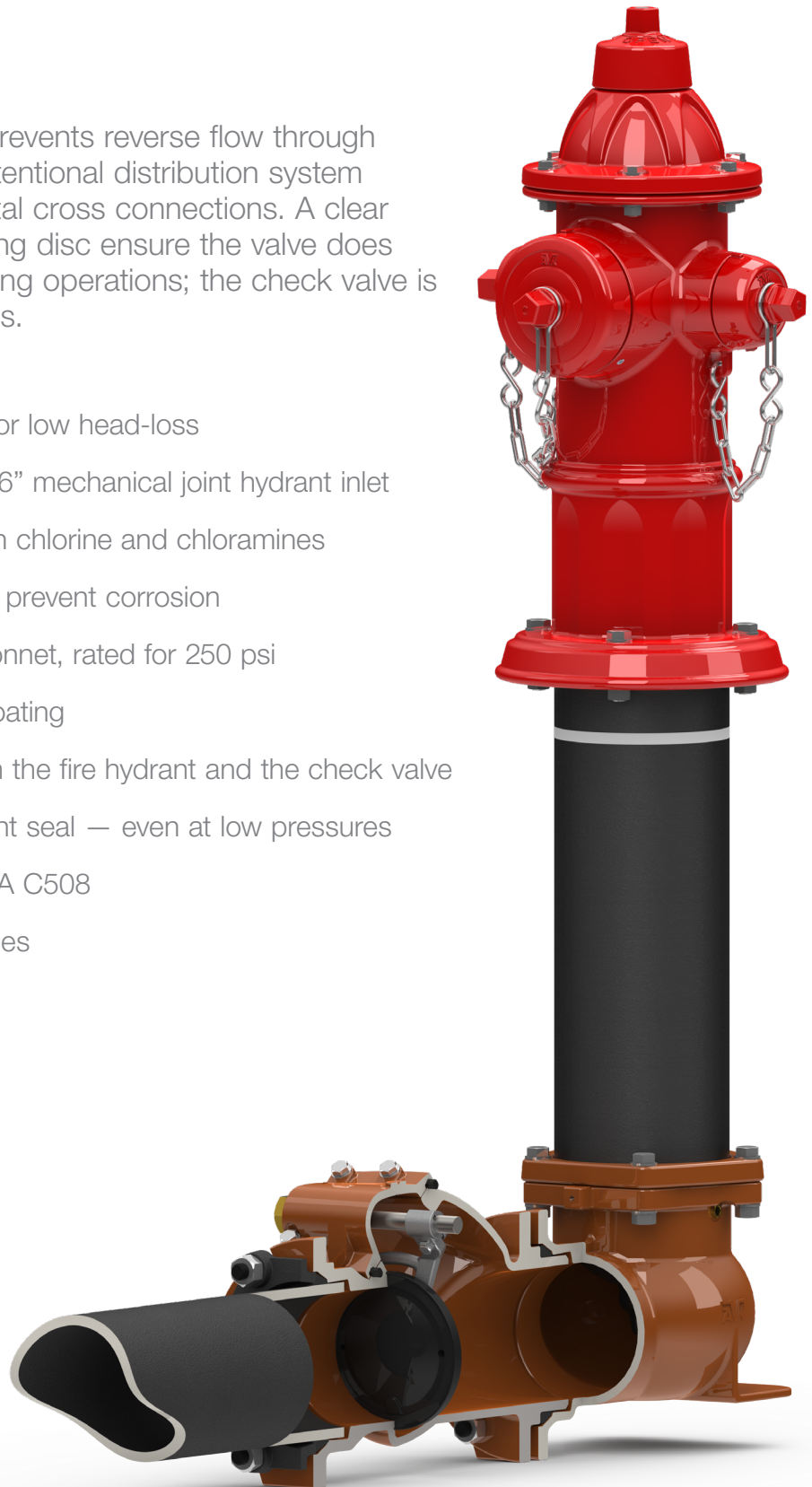



American AVK Company Locations

American AVK Company

2155 Meridian Blvd.
Minden, NV
89423
USA

Tel.: 775-552-1400
Fax.: 775-783-1031
sales@avkus.com
www.americanavk.com

Ti SALES

36 Hudson Rd
Sudbury MA 01776



800-225-4616
www.tisales.com

F99003/03-11-2019
Copyright©AVK Group A/S 2019

AVK

