

UL
LISTED
SIZES 2 1/2"-12"

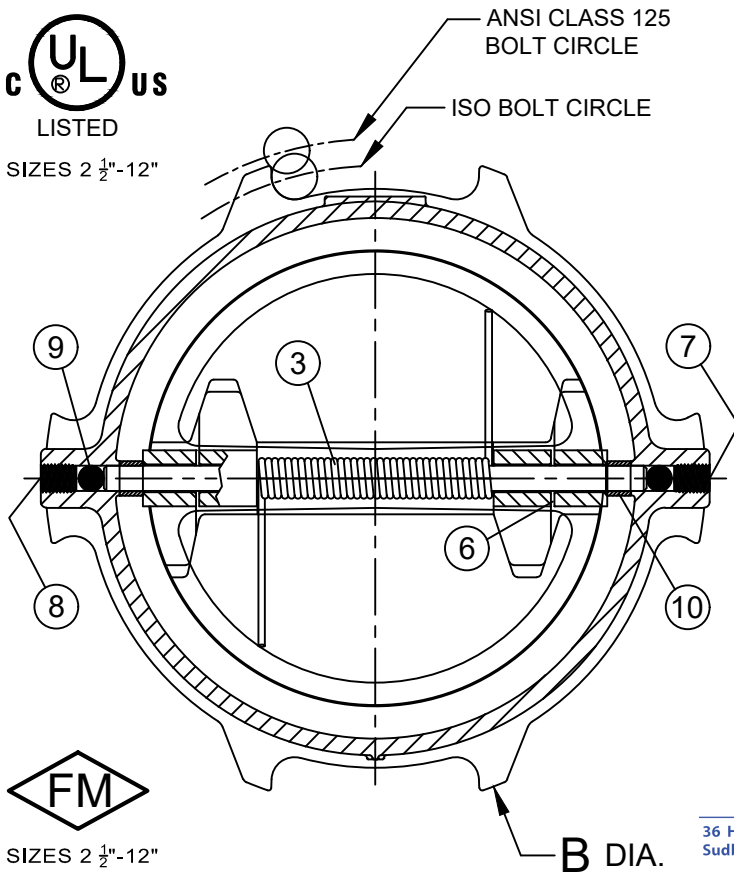

FM
SIZES 2 1/2"-12"

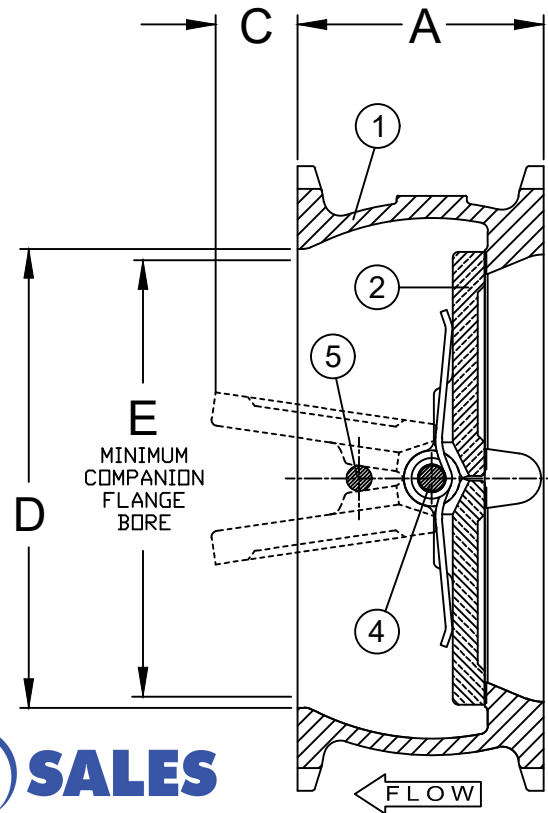

Ti SALES

36 Hudson Rd
Sudbury MA 01776 800-225-4616
www.tisales.com

- | | |
|------------------|------------------------|
| 1 BODY | 6 DISC THRUST BEARING |
| 2 DISC | 7 HINGE PIN RETAINER |
| 3 TORSION SPRING | 8 STOP PIN RETAINER |
| 4 DISC HINGE PIN | 9 STABILIZATION SPHERE |
| 5 DISC STOP PIN | 10 SPACER |

VAL-MATIC DUAL DISC CHECK VALVES CAN BE USED FOR HORIZONTAL FLOW OR VERTICAL FLOW-UP APPLICATIONS ONLY.

CAUTION: FOR HORIZONTAL FLOW APPLICATIONS, VALVE MUST BE INSTALLED WITH THE DISC HINGE PIN IN THE VERTICAL POSITION.

SEE DRAWING NO. VM-8802W.1-M FOR 2"-12" STANDARD MATERIALS OF CONSTRUCTION.

FOR AIR SERVICE APPLICATIONS, SEE DRAWING NO. VM-8902W.

SIZES 10" & 12" FURNISHED WITH LIFTING EYEBOLT.

DRAWING DEPICTS 10" VALVE SIZE TO SCALE.

ANSI CLASS 125 ISO PN10 / PN16

VALVE SIZE	MODEL NO.	A	B	C	D	E
2	8802WN	2.13	5.13	—	2.88	—
2 1/2	8825W	2.38	6.00	0.13	3.50	1.31
3	8803W	2.63	5.63	0.18	3.88	1.69
4	8804W	2.63	7.75	0.63	4.75	3.06
5	8805W	3.25	7.56	0.81	5.50	3.63
6	8806W	3.75	8.63	0.81	6.25	4.25
8	8808W	5.00	12.25	1.00	8.00	5.50
10	8810W	5.50	14.75	2.06	10.25	8.50
12	8812W	7.12	17.38	1.94	12.00	9.25

ANSI PRESSURE -TEMPERATURE RATING

TEMP. ° F.	MAXIMUM NON-SHOCK PRESSURE PSI
	DUCTILE IRON CONSTRUCTION
150 °	250
200 °	235
250 °	220
HYDROSTATIC TEST PRESSURE	500

Revised 1-31-20

WAFFER STYLE DUAL DISC® CHECK VALVE

DATE 2-16-11

VAL-MATIC

VALVE AND MANUFACTURING CORP.

DRWG. NO.

VMC-8802W