



2-12 in. (DN 50-300 mm) Wafer Style Dual Disc[®] Check Valve

Operation, Maintenance and Installation Manual

INTRODUCTION	1
RECEIVING AND STORAGE	1
DESCRIPTION OF OPERATION	1
INSTALLATION	2
VALVE CONSTRUCTION	3
MAINTENANCE.....	4
TROUBLESHOOTING.....	4
DISASSEMBLY	4
REASSEMBLY	4
PARTS AND SERVICE	5
WARRANTY	5



VAL-MATIC[®] VALVE AND MANUFACTURING CORP.

905 Riverside Dr. • Elmhurst, IL 60126
Phone (630) 941-7600 • Fax (630) 941-8042
www.valmatic.com

2-12 in. (DN 50-300 mm) WAFER STYLE DUAL DISC® CHECK VALVE OPERATION, MAINTENANCE AND INSTALLATION

INTRODUCTION

This manual will provide you with the information to properly install and maintain the valve to ensure a long service life. The Series 8800W Dual Disc® Check Valve is ruggedly constructed with bronze discs and stainless steel trim to give years of trouble free operation. The valve should be installed in horizontal or vertical flow up pipes carrying clean water. The valves can be equipped with special springs for operation in blower air service (Series 8900W).

The Dual Disc® Check Valve is designed to open fully to provide flow in the forward direction and close rapidly upon flow reversal. The valves are used to prevent reverse flow through pumps or piping systems. The size, cold working pressure, model number, and year of manufacture are stamped on the nameplate for reference.

This valve is not intended for fluids containing suspended solids such as wastewater. For wastewater and other high turbidity applications, use Val-Matic Series 500 Swing-Flex® Check Valves. The valve is also not intended for hazardous fluids.

CAUTION

This valve is not intended for fluids containing suspended solids or hazardous fluids.

RECEIVING AND STORAGE

Inspect valves upon receipt for damage in shipment. Unload all valves carefully to the ground without dropping. When lifting, the valve should be secured by the body and never lifted by the bronze or stainless steel trim. Lifting eyebolts are provided on NPS 10-12 (DN 250-300) valves.

The valves should remain boxed, clean and dry until installed to prevent weather related damage. For long term storage greater than six months, the rubber surfaces of the seat (when provided) should be coated with a thin film of FDA approved grease. Do not expose rubber seat to sunlight or ozone for any extended period.

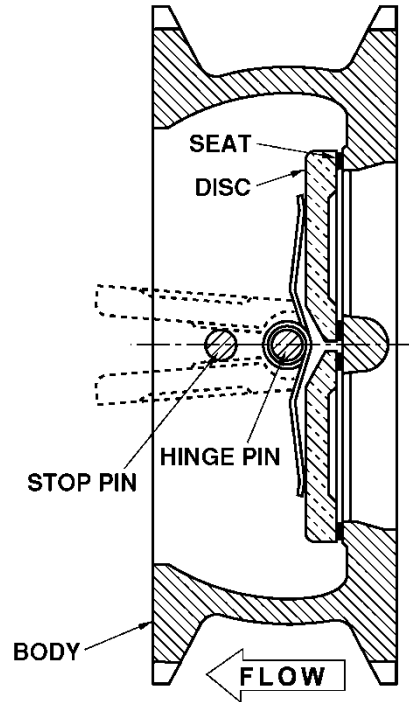

FIGURE 1. DUAL DISC® CHECK VALVE

DESCRIPTION OF OPERATION

The Dual Disc® Check Valve is designed to prevent reverse flow automatically. On pump start-up, the flow of water enters the valve from the seat end (right side in Figure 1) and forces the two discs open until they strike the disc stop pin. On pump shut-down, the torsion spring closes the disc before a flow reversal takes place.

The valve body is supplied with compact wafer ends as shown in Figure 1 for installation between mating flanges.

The only moving parts in the valve are the discs and spring. The discs and spring are guided in the body with a hinge pin and a full open disc stop pin. The pins are restrained in the body by stabilization spheres to prevent vibration. The valve also has a resilient seat for drop tight shut off.

INSTALLATION

The installation of the valve is important for its proper operation. The **flow arrow** on the valve body must point in the direction of flow when the system is in operation. The valve can be installed in horizontal lines with the disc hinge pin in the vertical position, or in vertical lines with the flow up. Valves for air service (Series 8900) require special springs to allow full valve opening.

CAUTION

When installed in horizontal lines, the check valve must be installed with the disc hinge pin in the vertical position

The valve should be installed between standard flanges that correspond to the dimensions given in ANSI B16.1 for 125# flanges or to those given in ISO 7005 for PN10 and PN16 flanges (See Table 1). Special integrally-cast locating tabs are provided around the exterior to enable the valves to fit between these different bolt patterns. (See Figure 2) The number of tabs varies by valve size. (Note: for some sizes tabs are not provided because the desired universal fit is accomplished without them)

The gasket can be rubber or compressed fiber. Ring gaskets are appropriate for this wafer style check valve, but full-face flange gaskets may be substituted. The studs or bolts used should span the full length of the valve.

Three diameters of straight pipe upstream of the valve are recommended to prevent turbulent flow streams through the valve, which can cause vibration and wear.

When mating the check valve with butterfly isolation valves, the isolation valve must be installed at least one diameter downstream of the check valve, because, in most sizes, the check valve discs extend beyond the downstream flange face and may interfere with the operation of adjacent valves. In these sizes, a short run of pipe or spacer is needed between the check valve and the isolation valve.

INSTALLATION PROCEDURE: Lower valve between mating flanges. NPS 10-12 (DN 250-300) valves are provided with a lifting eyebolt to aid in this process. Lubricate the flange bolts or studs and insert them around the flange. Lightly turn bolts or nuts until gaps are eliminated. The tightening of the nuts should then be done in graduated steps using the cross-over tightening method. Recommended lubricated torques for use with resilient gaskets are given in Table 1.

If leakage occurs, allow gaskets to absorb fluid and check torque and leakage after 24 hours. Do not exceed bolt rating or crush gasket more than 50 per cent of its thickness.

Table 1. Flange Bolt Torques

Size	Class	Bolt size	Qty	Bolt Torque
NPS 2	ANSI 125#	5/8 in.	4	25-75 ft-lb
DN 50	ISO 7005 PN16	M16	4	40-120 N-m
NPS 2.5	ANSI B16.1 125#	5/8 in.	4	25-75 ft-lb
DN 65	ISO 7005 PN16	M16	4	40-120 N-m
NPS 3	ANSI B16.1 125#	5/8 in.	4	25-75 ft-lb
DN 80	ISO 7005 PN16	M16	8	40-120 N-m
NPS 4	ANSI B16.1 125#	5/8 in.	8	25-75 ft-lb
DN 100	ISO 7005 PN16	M16	8	40-120 N-m
NPS 5	ANSI B16.1 125#	3/4 in.	8	40-120 ft-lb
DN 125	ISO 7005 PN16	M16	8	40-120 N-m
NPS 6	ANSI B16.1 125#	3/4 in.	8	40-120 ft-lb
DN 150	ISO 7005 PN16	M20	8	65-200 N-m
NPS 8	ANSI B16.1 125#	3/4 in.	8	50-150 ft-lb
DN 200	ISO 7005 PN10	M20	8	65-200 N-m
DN 200	ISO 7005 PN16	M20	12	65-200 N-m
NPS 10	ANSI B16.1 125#	7/8 in.	12	60-180 ft-lb
DN 250	ISO 7005 PN10	M20	12	65-200 N-m
DN 250	ISO 7005 PN16	M24	12	100-300 N-m
NPS 12	ANSI B16.1 125#	7/8 in.	12	65-200 ft-lb
DN 300	ISO 7005 PN10	M20	12	80-240 N-m
DN 300	ISO 7005 PN16	M24	12	125-375 N-m

CAUTION

The use of excessive bolt torque may damage valve.

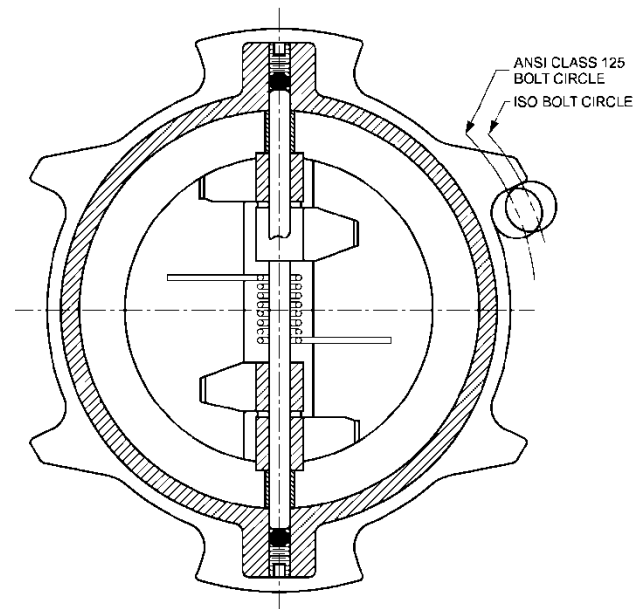

FIGURE 2. INTEGRALLY-CAST LOCATING TABS

VALVE CONSTRUCTION

The standard check valve body (1) is constructed of ductile iron. The discs (2) are bronze and the remaining metal components are type 316 stainless steel. The discs and torsion spring (3) are the only moving parts and require no maintenance or lubrication. The general details of construction are illustrated in Figure 3 and identified in Table 2.

The body is of the compact wafer style to fit between two pipe flanges. The resilient seat is bonded to the body and is not adjustable or replaceable in the field.

WARNING

Removal of mating flanges without draining the pipeline may cause injury or damage to the valve.

Table 2. Check Valve Parts List		
Item	Description	Material
1	Body	Cast Iron w/Buna-N Seat
2	Disc	Bronze
3	Spring*	T316 Stainless Steel
4	Hinge Pin	T316 Stainless Steel
5	Stop Pin	T316 Stainless Steel
6	Bearing*	T316 Stainless Steel
7	Hinge Pin Ret.*	T316 Stainless Steel
8	Stop Pin Ret.*	T316 Stainless Steel
9	Stab. Sphere*	Buna-N
10	Spacer*	T316 Stainless Steel

* Recommended Spare Part

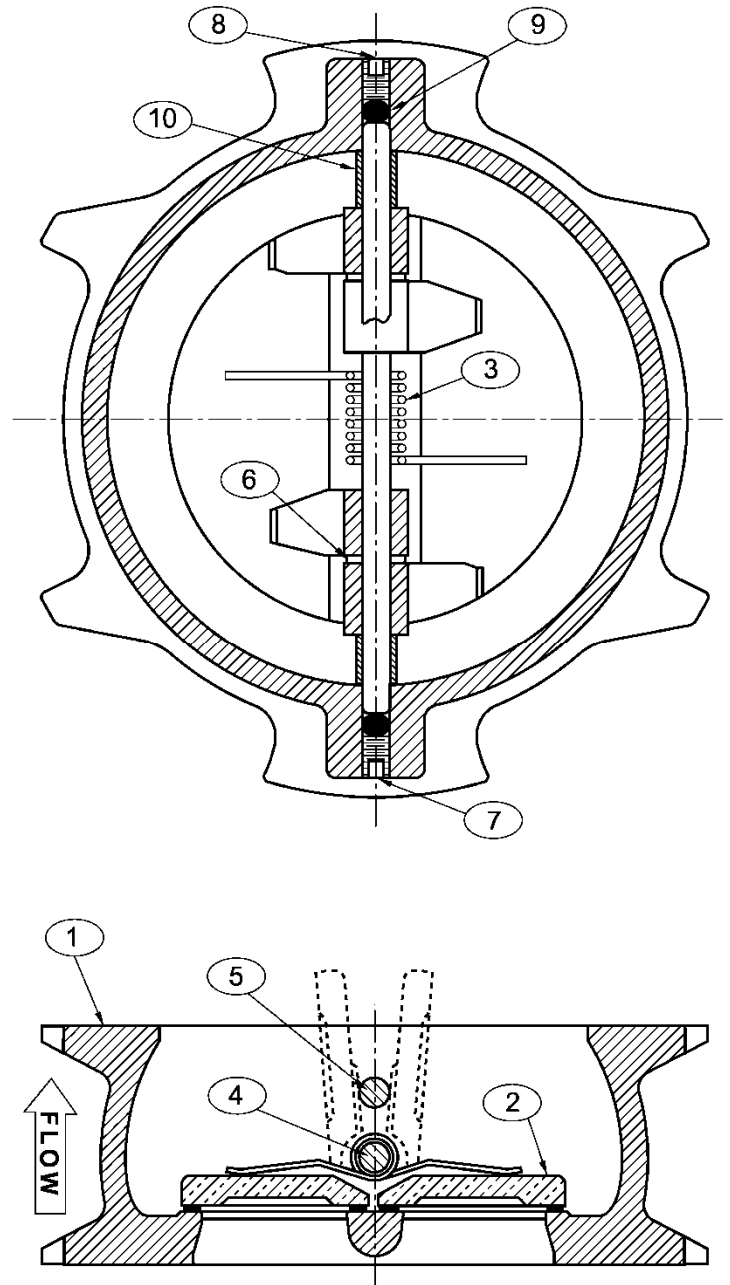

FIGURE 3. DUAL DISC® CHECK VALVE COMPONENTS

MAINTENANCE

Dual Disc® Check Valves require no scheduled lubrication or maintenance.

INSPECTION: Periodic inspection for leakage can be performed by listening for leakage noise from the valve while the pump is shut down. If leakage is heard, drain the pipeline, remove the valve, and inspect the seating surfaces for wear or damage. If the resilient seat is damaged, replace the valve or return the valve to the factory for refurbishing.

TROUBLESHOOTING

Several problems and solutions are presented below to assist you in troubleshooting the valve assembly in an efficient manner.

- **Valve Chatters or Vibrates:** Verify that velocity is at least 4 feet per second (consult the factory for air service). A partially open valve will wear prematurely. Verify that there are three diameters of straight pipe upstream.
- **Valve Leakage:** Check gaskets and flange bolt torque for flange leakage. Drain line, remove valve, and inspect seating surfaces.
- **Valve Does Not Pass Flow:** Check flow arrow direction on valve body. Verify that downstream isolation valve is open and there is no line blockage downstream.
- **Valve Slams:** Remove valve and inspect spring. Heavier springs can be furnished for severe high-head applications. Consult factory if the valve is installed in a vertical pipe with the flow downward.

DISASSEMBLY

The valve should be removed from the pipeline for disassembly. All work on the valve should be performed by a skilled mechanic with proper tools. Refer to Figure 3.

WARNING

The line must be drained before removing the valve or pressure may be released causing injury.

1. Remove the valve from the pipeline. NPS 10-12 (DN 250-300) valves are provided with a lifting eyebolt to aid in this process. Lay valve on flat surface or bench with the flow arrow facing upwards.
2. Remove the retainer set screws (7) & (8) and the rubber spheres (9). The retainer set screws are metric and should be uninstalled using standard metric hex drive bits or wrenches.

3. Drive out the pins (4 and 5) with a round bar or punch while pressing down on the spring (3) to prevent it from unwinding.
4. Lift discs (2) from body. Inspect pins and seating surfaces for wear. The shaft diameter is normally about 1/16 in. (1.5 mm) smaller in diameter than the hole in the disc lugs. Some minor dents and discoloration are normal. Wear areas in the resilient seat will cause leakage and require valve replacement or refurbishing at the factory.
5. Remove spring (3) and check for wear or cracks.

REASSEMBLY

All parts must be clean and the gasket surfaces should be cleaned with a stiff wire brush in the direction of the serrations or machine marks. Worn parts, gaskets, and seals should be replaced during reassembly.

1. Lay body on flat surface with arrow facing upwards. Carefully place the two discs with the machined sealing surfaces down on the body sealing surface. Align the disc lugs with the pin holes in the body.
2. Insert the disc hinge pin into the hole on one side of the body, but not through the disc lugs. Install a spacer (10) between the inside diameter of the body and the disc lug. Push the disc hinge pin further to engage the first disc lug.
3. Install a thrust bearing (6) between the first and second disc lugs and push the pin further to engage the second disc lug.
4. While holding the torsion spring (3) with one of the ends facing you, wind the rear tab 180 degrees in a clockwise direction and then press the spring between the two sets of disc lugs. Engage the pin further to retain the spring and the third disc lug. The legs of the spring should apply a downward force on the discs.
5. While pushing the pin further, install the second thrust bearing (6) and the fourth disc lug, and then the second spacer (10). The pin should now be centered in the body and the disc should rotate without binding.
6. Insert the disc stop pin (5) into the holes in the body.
7. Insert a sphere (9) into each of the four pin holes.

REASSEMBLY (Continued)

8. Install one of the four retainer set screws (7) & (8) into each the tapped pin bores, and tighten into place. The retainer set screws are metric and should be installed using standard metric hex drive bits or wrenches. The screws should be tightened until they are about one turn past the point of being flush with the exterior surface of the valve body.
9. Stand the valve on its edge with the pins vertical, and verify smooth operation of the valve before installation into the pipeline. Apply a light coat of silicone grease on the rubber seat for air service valves (Series 8900).

PARTS AND SERVICE

Parts and service are available from your local representative or the factory. Make note of the Valve Size and Model Number located on the valve nameplate and contact:

Val-Matic Valve and Manufacturing Corp.
905 Riverside Drive
Elmhurst, IL 60126
Phone: (630) 941-7600
Fax: (630) 941-8042
www.valmatic.com

A sales representative will quote prices for parts or arrange for service as needed.

LIMITED WARRANTY

All products are warranted to be free of defects in material and workmanship for a period of one year from the date of shipment, subject to the limitations below.

If the purchaser believes a product is defective, the purchaser shall: (a) Notify the manufacturer, state the alleged defect and request permission to return the product; (b) if permission is given, return the product with transportation prepaid. If the product is accepted for return and found to be defective, the manufacturer will, at his discretion, either repair or replace the product, f.o.b. factory, within 60 days of receipt, or refund the purchase price. Other than to repair, replace or refund as described above, purchaser agrees that manufacturer shall not be liable for any loss, costs, expenses or damages of any kind arising out of the product, its use, installation or replacement, labeling, instructions, information or technical data of any kind, description of product use, sample or model, warnings or lack of any of the foregoing. NO OTHER WARRANTIES, WRITTEN OR ORAL, EXPRESS OR IMPLIED, INCLUDING THE WARRANTIES OF FITNESS FOR A PARTICULAR PURPOSE AND MERCHANTABILITY, ARE MADE OR AUTHORIZED. NO AFFIRMATION OF FACT, PROMISE, DESCRIPTION OF PRODUCT OF USE OR SAMPLE OR MODEL SHALL CREATE ANY WARRANTY FROM MANUFACTURER, UNLESS SIGNED BY THE PRESIDENT OF THE MANUFACTURER. These products are not manufactured, sold or intended for personal, family or household purposes.



36 Hudson Rd
Sudbury MA 01776



800-225-4616
www.tisales.com



VAL-MATIC® VALVE AND MANUFACTURING CORP.

905 Riverside Dr. • Elmhurst, IL 60126
Phone (630) 941-7600 • Fax (630) 941-8042
www.valmatic.com