

ECLIPSE™ NO. 2 Post Hydrant

NON-FREEZING



- New full-port nozzle.
- One or two nozzles.
- Any size you wish up to 2 1/2" NST in size.

Available with any depth of bury you desire.

Inlet can be 2", 2 1/2" or 3" iron pipe. Mechanical joints 2", 3" and 4" also available.



← You can replace interior parts without disturbing any connections. Just unbolt the top cap and withdraw the inside working parts.

← All hydrants now furnished with ductile iron pipe trench stocks to provide corrosion resistance for longer life.

← Has 2 - 3/16" valve opening.

→ DRAIN



THE KUPFERLE FOUNDRY COMPANY
813 HEMPSTEAD STREET / ST. LOUIS, MISSOURI 63102
314-231-8738 FAX# 314-231-2820
<http://www.hydrants.com>

Call for Drawings
and Specs for
AutoCad
1-800-231-3990
(toll free)
or download
from website

Distributed by:

Ti SALES

36 Hudson Rd
Sudbury MA 01776



800-225-4616
www.tisales.com

THE EASIEST TO SERVICE



UNDO 4 BOLTS



PULL UP TOP CAP



PULL OUT ROD



INSPECT PLUNGER

Installation drawing and specification

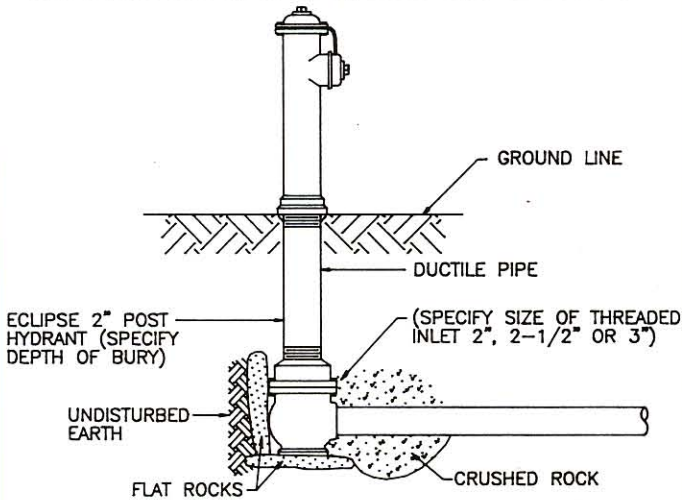

Hydrants shall be self-draining, non-freezing, compression type with 2 - $\frac{3}{16}$ " main valve opening. Inlet connection shall be (2" IP, 2 - $\frac{1}{2}$ " IP, 3" IP, 2" MJ, 3" MJ or 4" MJ). Outlet shall be (1 - $\frac{1}{4}$ ", 1 - $\frac{1}{2}$ ", 2" or 2 - $\frac{1}{2}$ " IP or NST).

Hydrants shall have a 3" ductile iron pipe riser with a cast iron top stock, and non-turning operating rod. Principal interior operating parts shall be brass and removable from the hydrant for servicing without excavating the hydrant.

Hydrants shall be set in 4 cubic feet of crushed stone to allow for proper drainage of the hydrant. Recommendations of the AWWA should be followed when installing the hydrants.

Post hydrants shall be Eclipse No. 2 Post Hydrants as manufactured by John C. Kupferle Foundry Company, St. Louis, Missouri.



EVERY HYDRANT MARKED WITH "OPEN" ARROW AND TOLL-FREE NUMBER



HANDWHEEL OPTION



LOCKING WRENCH OPTION





THE KUPFERLE FOUNDRY COMPANY

813 HEMPSTEAD STREET / ST. LOUIS, MISSOURI 63102
 314-231-8738 FAX# 314-231-2820
<http://www.hydrants.com>



Call Toll Free
1-888-HYDRANT