

SUBMITTAL INFORMATION

Stainless Steel Tapping Sleeve - (FAST-xxxx-x-MJ style)

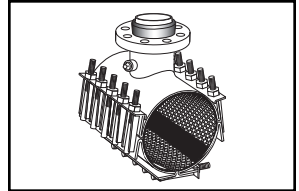

STAINLESS STEEL TAPPING SLEEVE WITH MECHANICAL JOINT OUTLET

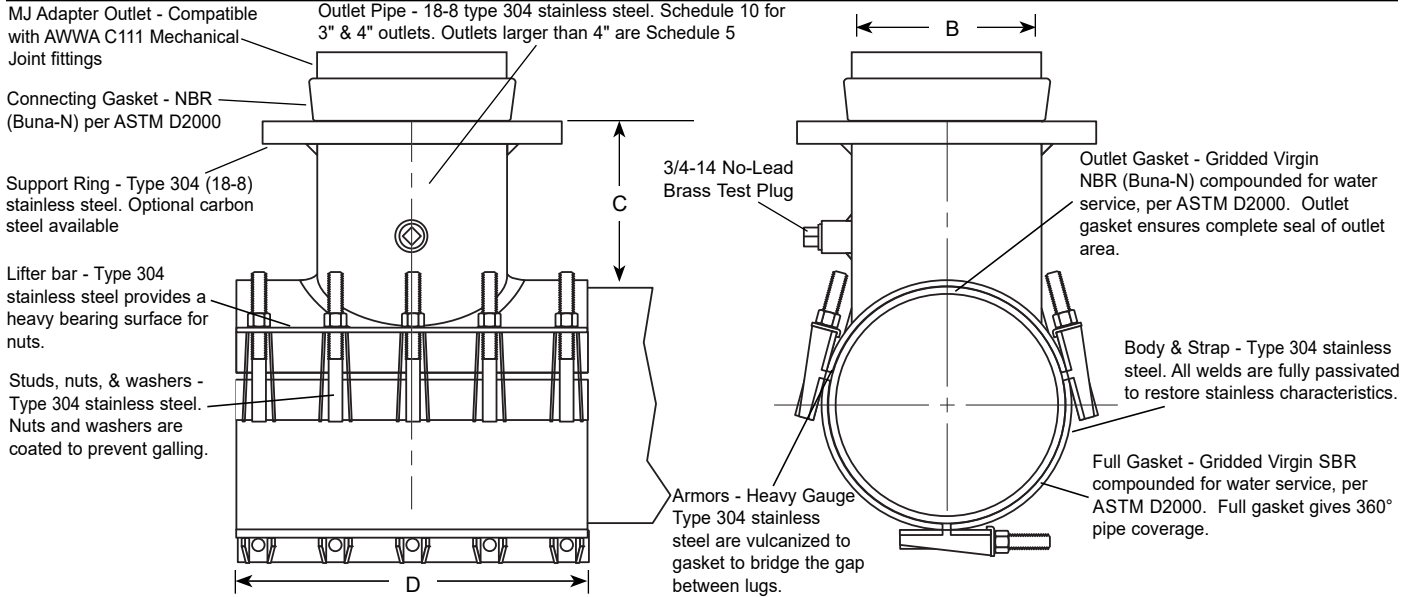

NOM. PIPE SIZE	SLEEVE O.D. RANGE	CATALOG NUMBER**	BY	SS ** OUTLET SIZE/CODE	APPROX. WT.	NOM. DIM. - INCHES			SADDLE THICKNESS (GAUGE)	STRAP THICKNESS (GAUGE)	STUD SIZE	NO. STUDS	WORKING PRESSURE	✓ SUBMITTED ITEM(S)
						B	C	D						
16"	17.30 - 17.70	FAST-1770-x-MJ	X	4	75	4-1/4	5-3/16	16	.105" (12)	.060" (16)	5/8"	15	200	
	17.40 - 17.80	FAST-1780-x-MJ		6	79	6-13/32	5-1/2	16				15		
	17.75 - 18.15	FAST-1815-x-MJ		8	100	8-13/32	5-5/8	20				15		
	18.15 - 18.62	FAST-1862-x-MJ		10	105	10-31/64	6-1/8	20				15		
	18.60 - 19.00	FAST-1900-x-MJ		12	141	12-27/64	6-1/4	24				15		
	18.80 - 19.20	FAST-1920-x-MJ		12	141	12-27/64	6-1/4	24				15		
18"	19.30 - 19.70	FAST-1970-x-MJ	X	4	77	4-1/4	5-3/16	16	.105" (12)	.060" (16)	5/8"	15	175	
	19.30 - 19.70	FAST-1970-x-MJ		6	81	6-13/32	5-1/2	16				15		
	19.50 - 19.92	FAST-1992-x-MJ		8	103	8-13/32	5-5/8	20				18		
	19.50 - 19.92	FAST-1992-x-MJ		10	108	10-31/64	6-1/8	20				18		
	19.80 - 20.20	FAST-2020-x-MJ		12	144	12-27/64	6-1/4	24				21		
20"	20.20 - 20.60	FAST-2060-x-MJ	X	4	87	4-1/4	5-3/16	16	.105" (12)	.060" (16)	5/8"	15	175	
	20.90 - 21.30	FAST-2130-x-MJ		6	91	6-13/32	5-1/2	16				15		
	21.40 - 21.80	FAST-2180-x-MJ		8	115	8-13/32	5-5/8	20				18		
	21.86 - 22.26	FAST-2226-x-MJ		10	120	10-31/64	6-1/8	20				18		
	22.30 - 22.70	FAST-2270-x-MJ		12	158	12-27/64	6-1/4	24				21		
	23.40 - 23.80	FAST-2380-x-MJ		12	158	12-27/64	6-1/4	24				21		
24"	23.80-24.20	FAST-2420-x-MJ	X	4	75	4-1/4	5-3/16	16	.105" (12)	.060" (16)	5/8"	15	150	
	23.80-24.20	FAST-2420-x-MJ		6	79	6-13/32	5-1/2	16				15		
	23.80-24.20	FAST-2420-x-MJ		8	100	8-13/32	5-5/8	20				18		
	25.60-26.00	FAST-2600-x-MJ		10	105	10-31/64	6-1/8	20				18		
	25.60-26.00	FAST-2600-x-MJ		12	141	12-27/64	6-1/4	24				21		

Highlighted ranges are recommended for ductile iron pipe and C905 PVC applications.

** To order: Add flanged outlet size to catalog number. Example: The complete FAST catalog number for an 20" pipe (21.60 O.D.) with a 12" stainless steel outlet is FAST-2160-12-MJ. For a carbon steel outlet, insert "A" into the catalog number. Example: FAST-2160-12A-MJ

FEATURES

- Body, straps and UNC threaded studs are made of type 304 stainless steel. Support ring can be either type 304 stainless steel or ASTM A36 carbon steel
- All welds are fully passivated for corrosion resistance
- UL Classified to NSF Standard 61

The Ford Meter Box Company considers the information in this submittal form to be correct at the time of publication. Item and option availability, including specifications, are subject to change without notice. Please verify that your product information is current.



The Ford Meter Box Company, Inc.

P.O. Box 443, Wabash, Indiana U.S.A. 46992-0443

Phone: 260-563-3171 / Fax: 800-826-3487

Overseas Fax: 260-563-0167

www.fordmeterbox.com

04/25/18

Submitted By:



36 Hudson Rd
Sudbury MA 01776



800-225-4616
www.tisales.com