

SUBMITTAL INFORMATION

Stainless Steel Tapping Sleeve - (FAST-xxx-x-MJ style)

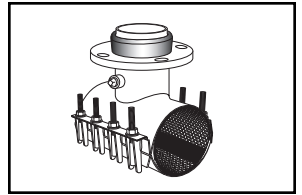

STAINLESS STEEL TAPPING SLEEVE WITH MECHANICAL JOINT OUTLET

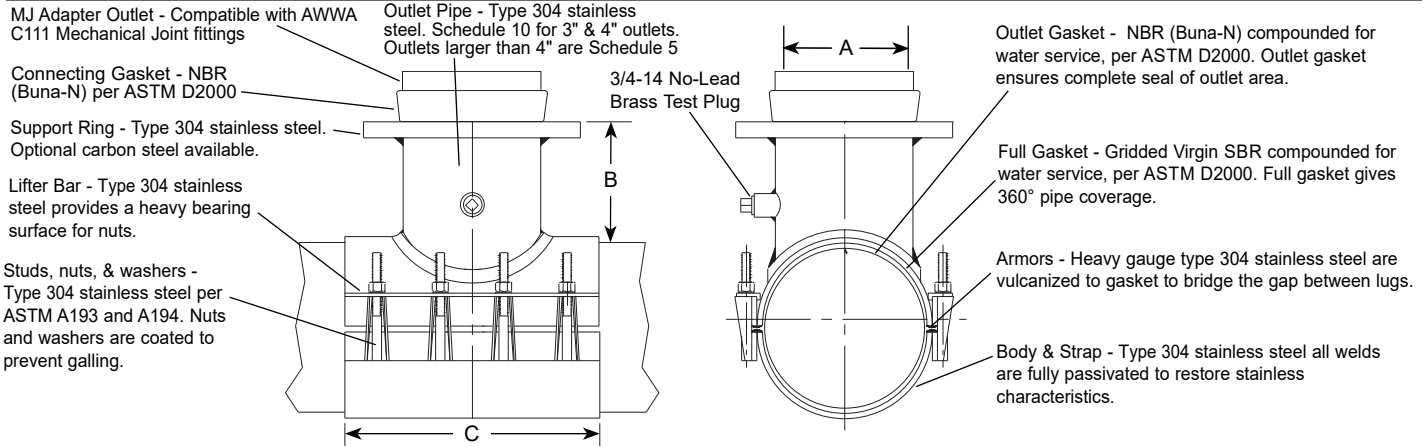

NOM. PIPE SIZE	SLEEVE O.D. RANGE (IN.)	CATALOG NUMBER**	BY	SS** OUTLET SIZE/CODE	APPROX. WT. (LBS.)	NOMINAL DIMENSIONS - INCHES			SADDLE THICKNESS (GAUGE)	STRAP THICKNESS (GAUGE)	STUD SIZE	No. STUDS	✓ SUBMITTED ITEM(S)
						A	B	C					
3"	3.50-3.96	FAST-396-x-MJ	X	3	25	3-1/4	5-3/16	15	.075" (14)	.048" (18)	5/8"	8	
	4.50-4.80	FAST-480-x-MJ		3	28	3-1/4	5-3/16	15					
4"	4.80-5.10	FAST-510-x-MJ	X	4	36	4-1/4	5-3/16	15	.075" (14)	.048" (18)	5/8"	8	
	5.05-5.30	FAST-530-x-MJ		4	36	4-1/4	5-3/16						
6"	6.60-7.00	FAST-700-x-MJ	X	3	33	3-1/4	5-3/16	15	.105" (12)	.048" (18)	5/8"	8	
	6.90-7.30	FAST-730-x-MJ		4	39	4-1/4	5-3/16						
	7.10-7.50	FAST-750-x-MJ		6	43	6-13/32	5-1/2						
8"	8.63-9.05	FAST-905-x-MJ	X	3	38	3-1/4	5-3/16	15	.105" (12)	.048" (18)	5/8"	8	
	9.05-9.45	FAST-945-x-MJ		4	43	4-1/4	5-3/16					8	
	9.30-9.70	FAST-970-x-MJ		6	47	6-13/32	5-1/2					8	
				8	64	8-13/32	5-5/8					12	
10"	10.75-11.15	FAST-1115-x-MJ	X	3	40	3-1/4	5-3/16	15	.105" (12)	.048" (18)	5/8"	8	
	11.05-11.45	FAST-1145-x-MJ		4	46	4-1/4	5-3/16					8	
	11.75-12.15	FAST-1215-x-MJ		6	50	6-13/32	5-1/2					8	
				8	68	8-13/32	5-5/8					12	
				10	73	10-31/64	6-1/8					12	
12"	12.75-13.20	FAST-1320-x-MJ	X	3	43	3-1/4	5-3/16	15	.105" (12)	.048" (18)	5/8"	8	
	13.10-13.50	FAST-1350-x-MJ		4	49	4-1/4	5-3/16					8	
	14.00-14.40	FAST-1440-x-MJ		6	53	6-13/32	5-1/2					8	
				8	72	8-13/32	5-5/8					12	
				10	77	10-31/64	6-1/8					12	
				12	107	12-27/64	6-1/4					14	
14"	15.10-15.50	FAST-1550-x-MJ	X	3	65	3-1/4	5-3/16	16	.105" (12)	.060" (16)	5/8"	10	
	15.30-15.70	FAST-1570-x-MJ		4	70	4-1/4	5-3/16					10	
	15.80-16.20	FAST-1620-x-MJ		6	74	6-13/32	5-1/2					10	
	16.48-16.88	FAST-1688-x-MJ		8	93	8-13/32	5-5/8					12	
				10	98	10-31/64	6-1/8					12	
				12	132	12-27/64	6-1/4					14	

Highlighted ranges are recommended for ductile iron pipe and C900/C905 PVC applications.

** To order: Add outlet size to catalog number. Example: The complete FAST catalog number for an 8" pipe (9.05 O.D.) with a 6" stainless steel outlet is FAST-945-6-MJ. For a carbon steel outlet, add "A" to the catalog number. Example: FAST-945-6A-MJ

FEATURES

- Body, straps and UNC threaded studs are made of type 304 stainless steel. Support ring can be either type 304 stainless steel or ASTM A36 carbon steel.
- All welds are fully passivated for corrosion resistance.
- 3"-12" tapping sleeves rated for 250 psi working pressure
- Certified to NSF/ANSI 61

The Ford Meter Box Company considers the information in this submittal form to be correct at the time of publication. Item and option availability, including specifications, are subject to change without notice. Please verify that your product information is current. Our standard warranty applies.



The Ford Meter Box Company, Inc.
 P.O. Box 443, Wabash, Indiana U.S.A. 46992-0443
 Phone: 260-563-3171 / Fax: 800-826-3487
 Overseas Fax: 260-563-0167
 www.fordmeterbox.com

10/14/20

Submitted By:



36 Hudson Rd
 Sudbury MA 01776



800-225-4616
 www.tisales.com