

InformationSheet

Fluoride Saturator Model No. 28850

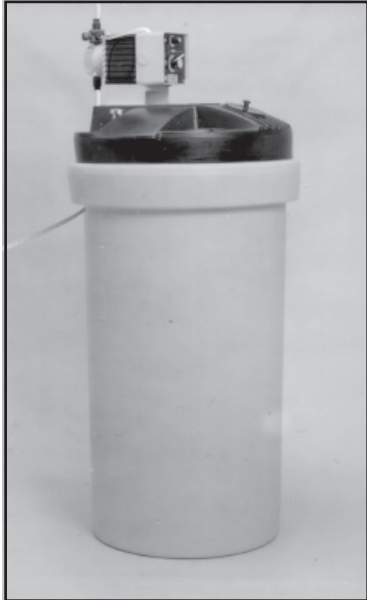

- *Up-Flow Design*
- *Low Maintenance*
- *Continuous Duty*
- *Integrated Cover Assembly*
- *Fluoridate Water Flows to 10,000 GPM*

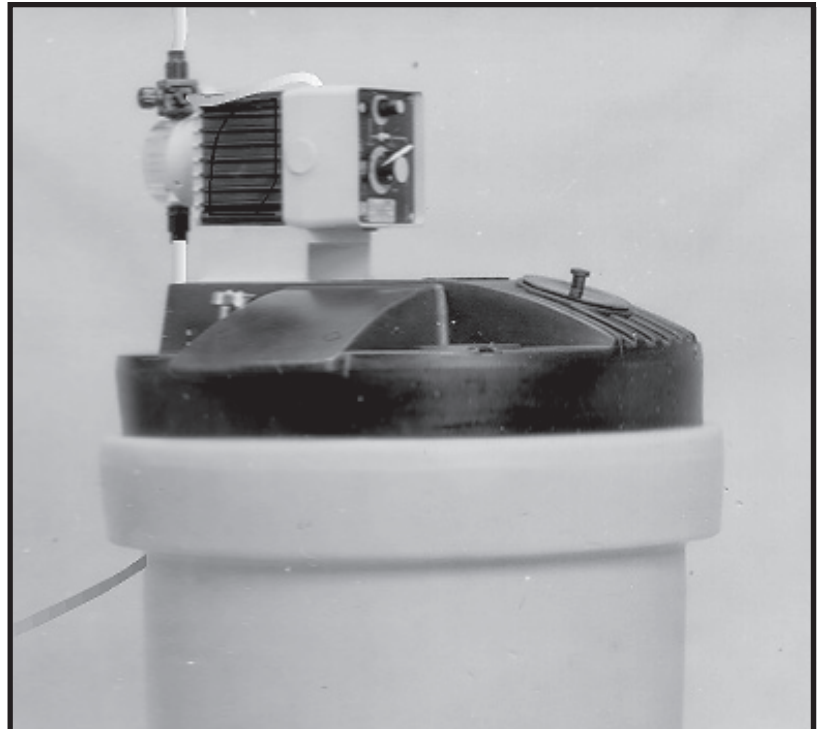

201 Ivyland Road
Ivyland, PA 18974 USA
TEL: 215-293-0401
FAX: 215-293-0445
<http://www.lmipumps.com>



Replaces same of Rev.C 3/98
1076.D 1/04

Instruction Sheet

Fluoride Saturator Model No. 28850

- *Automatic Solution Level Control – Continuous Duty*
- *Up-Flow Design – Minimal Maintenance*
- *Molded Polyethylene Cover – Component Protection*
- *Compact – Economical – Easily Installed*
- *For Sodium Fluoride*

Component Parts

Tank Cover

- Tank cover with hinged fill hatch cover, pump mounting recess on molded polyethylene cover.
- Water inlet for .375" OD polyethylene 10 ft (3 m) tubing included
- Syphon breaker
- Solenoid valve - Flow control, 115 VAC
- Liquid level switch, 12 VAC
- Suction tube strainer, PVC
- Six (6) foot power cord

Distributor Tube Assembly

- Flexible vinyl tubing connector, from water inlet control to distributor
- Rigid PVC anti-rise pipe
- Distributor tubes, rigid PVC

Tank Assembly

- Fifty (50) gallon tank, yellow polyethylene
- 3/4" NPT female connection

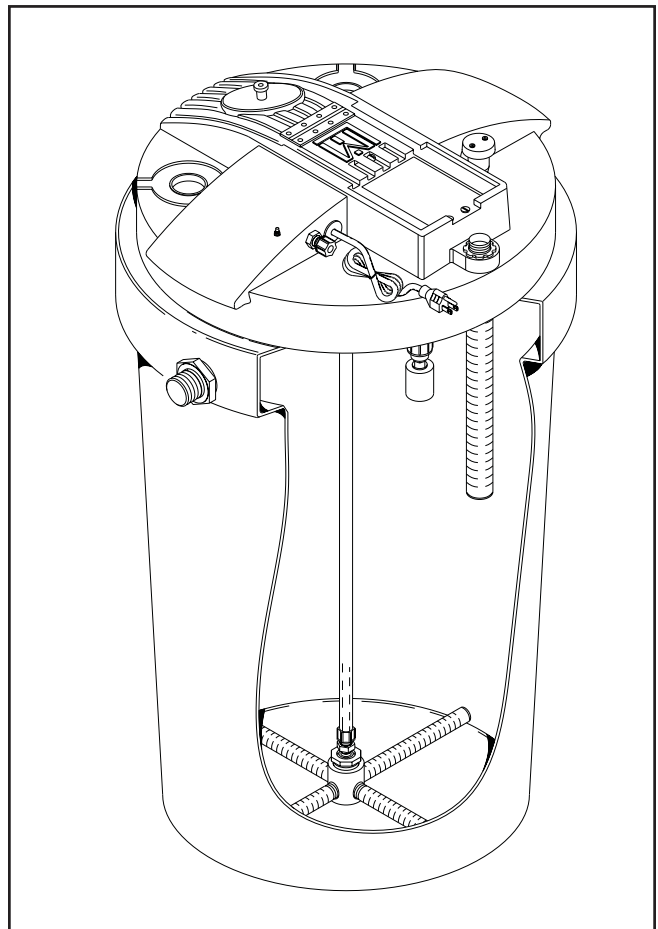

Operation

Design Simplicity

The LMI sodium fluoride saturator provides an easily maintained source of saturated sodium fluoride solution; the unit is designed for efficiency economy, ease of installation and minimal maintenance. The complete saturator assembly includes cover, distributor tube assembly and tank.

Integrated Cover Assembly

The cover consists of a tank cover which houses the saturator components, including solenoid valve, syphon breaker, and liquid level switch. In addition, the cover also provides a suction tube strainer, recess for pump mounting and a hinged fill hatch cover. Push button light switch allows for visual inspection of fluoride bed level.

Up-Flow Saturation

The integrally mounted liquid level switch controls solenoid valve operation to maintain a proper solution level in the tank. The distributor tube assembly supplies fresh water to a bed of sodium fluoride at tank bottom. Water, dispersed by the distributor tubes 'flows up' through and dissolves the powder/crystals of sodium fluoride to provide a saturated (4%) solution.

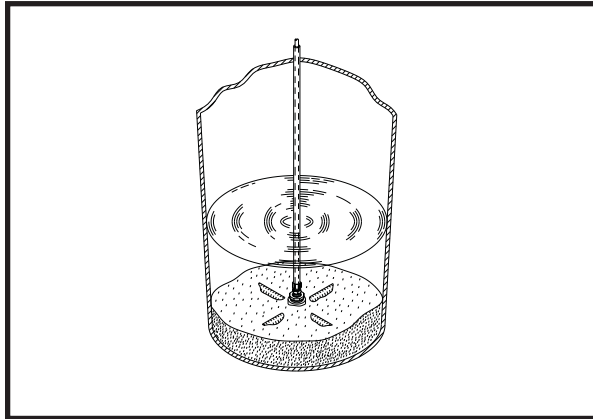

Metering Pump

LMI chemical metering pumps can be conveniently mounted in the recess provided on the saturator cover assembly. Pumps with liquid handling assembly materials of Hypalon, PVC and acrylic are generally recommended for pumping sodium fluoride solution.

Series A1, A9, B7, B9, C7 and C9 pumps can be used for addition of sodium fluoride solution with constant water flow rate applications.

Series A7, B7 and C7 pumps can be used with applications requiring automatic output control either with an LMI RFP flowmeter for flow proportional treatment or with an LMI Liquitron current to frequency converter for instrument responsive proportional treatment.

Solution Tank

The fifty (50) gallon tank is UV light resistant, yellow polyethylene, with tapered sides, five (5) gallon graduate marking, and is complete with overflow connection installed.

Typical Installation

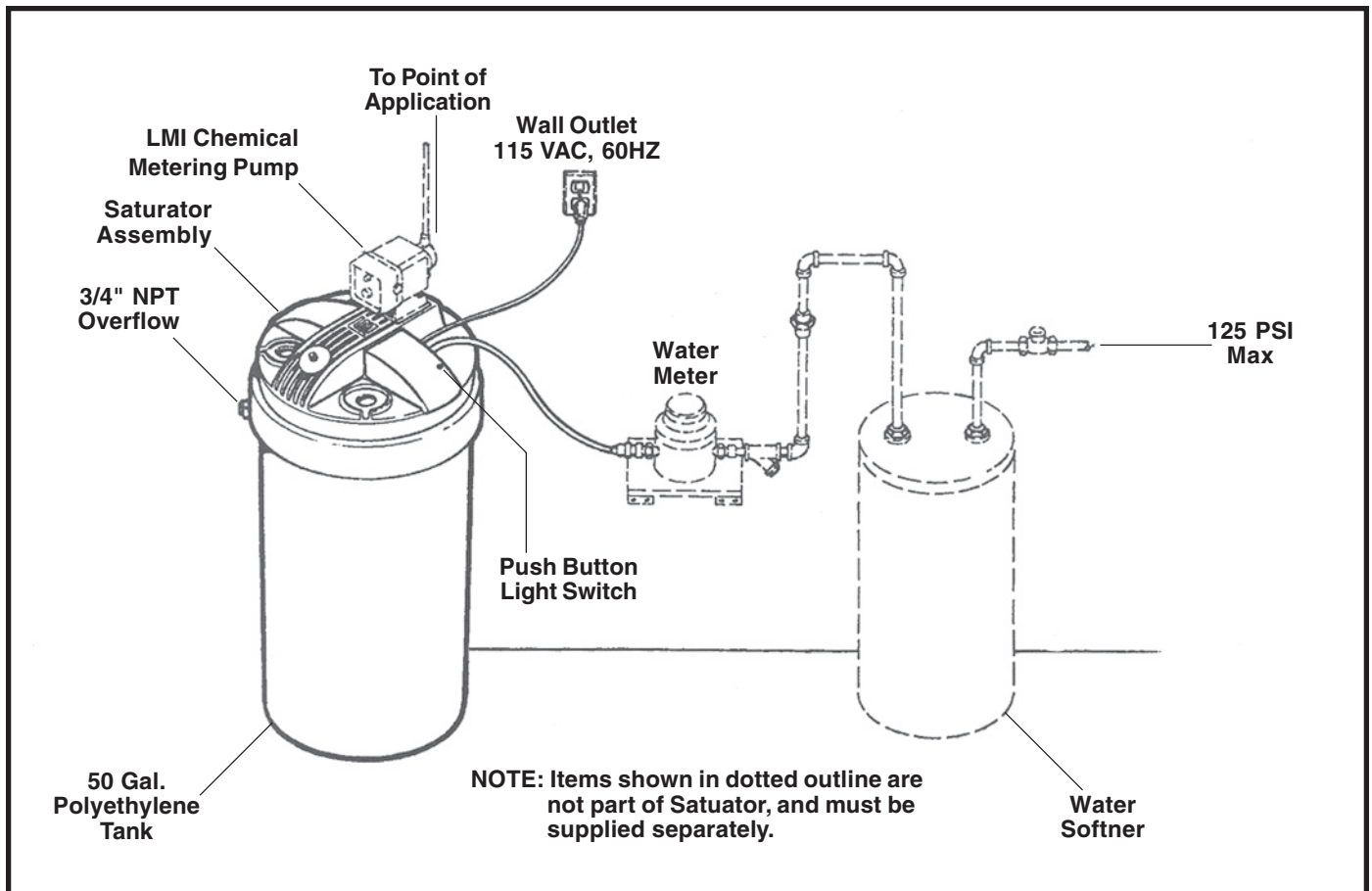

Dimensions

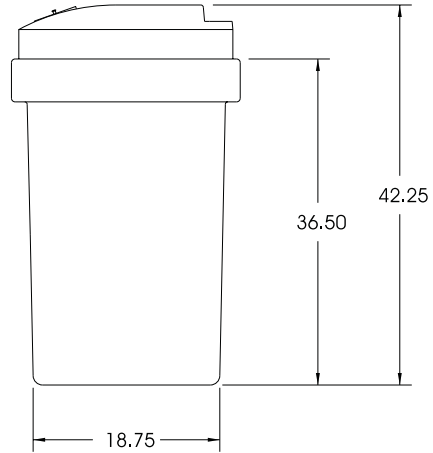
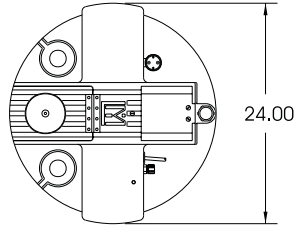

Shipping Dimensions: 24 x 24 x 47 in
(609 x 609 x 1192 mm)
Shipping Weight: 37 lbs (16.8 kg)
Power Requirements: During fill cycle only,
115 VAC, 60 Hz, 25 watts

***For Automatic Flow
Proportional Feed***

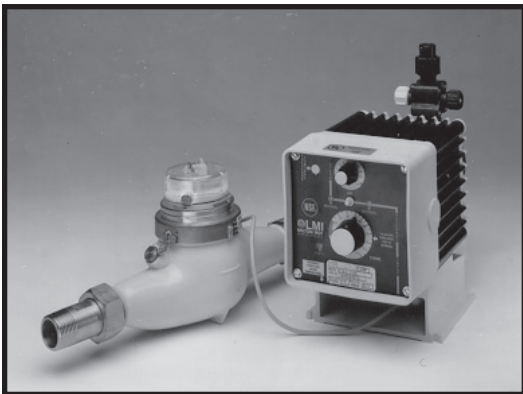

***For Instrument Responsive
Proportional Feed***

