



36 Hudson Rd  
Sudbury MA 01776



800-225-4616  
www.tisales.com



THE FORD METER BOX COMPANY, INC.  
CERTIFIED TO ISO 9001:2015  
10004466

# Section N

# Ford<sup>®</sup> Fabricated Steel Products



# Contents

	Page
Product Numbering System . . . . .	3
Information . . . . .	4 - 7
Steel Transition Coupling / 4" through 24" / <b>Style FC23 / Style FC24</b> . . . . .	8 - 11
Steel Coupling / 1/2" through 12" / <b>Style FC3</b> . . . . .	12 & 13
Steel Coupling / 14" through 60" / <b>Style FC4</b> . . . . .	14 -16
Steel Coupling with End Cap / 14" through 24" / <b>Style FC4</b> . . . . .	17
Steel Transition Coupling / 14" through 60" / <b>Style FC5</b> . . . . .	18 & 19
Steel Reducing Coupling / 2" through 60" / <b>Style FC6</b> . . . . .	20 & 21
Steel Flange Coupling Adapter / 4" through 48" / <b>Style FCA</b> . . . . .	22 - 25
Ford Dismantling Joint / 4" through 36" / <b>Style FDJ</b> . . . . .	26
Steel Expansion Joint / 4" through 24" / <b>Style FEJ</b> . . . . .	27 - 29
Restrainer Assembly / 4" through 16" / <b>Style FR</b> . . . . .	30 & 31
Steel Weld-On Tapping Sleeve / 3" through 48" / <b>Style FWS</b> . . . . .	32
Miscellaneous Custom Steel Fittings . . . . .	33
Stainless Steel Inserts for HDPE Pipe . . . . .	34
Pipe O.D. Chart for 3" through 60" pipe . . . . .	35
Installation Instructions for Ford Fabricated Steel Couplings . . . . .	36
Warranty . . . . .	40

*The information in this catalog is correct at the time of publication. Item and option availability, including specifications are subject to change without notice. **Items in this catalog section are not returnable and are subject to cancellation charges.***

The Ford Meter Box Company, Inc. manufacturing facilities are at the following locations:

1. The Ford Meter Box Company, Inc. - Main Office  
775 Manchester Avenue, P.O. Box 443  
Wabash, Indiana 46992-0443  
Phone: 260-563-3171 FAX: 800-826-3487
2. The Ford Meter Box Company, Inc. - Pipe Products Division  
815 Miles Parkway  
Pell City, Alabama 35125  
Phone: 205-884-4480 FAX: 205-884-4484

# FABRICATED STEEL PRODUCTS SECTION N

**TYPE OF COUPLING**  
**FC23 or FC24** = Steel Transition Coupling for 4" thru 24"  
**\*FC3** = Steel Coupling for 1/2" thru 12"  
**FC4** = Steel Coupling for 14" thru 60"  
**FC5** = Steel Transition Coupling for 14" thru 60"  
**FC6** = Steel Reducing Coupling for 2" thru 60"

Note: Custom fabrications are welcomed.

**CENTER SLEEVE  
WALL THICKNESS**  
**A** = 1/4" steel  
**B** = 3/8" steel  
 (use only with FC4 & FC5)

**COUPLING LENGTH**  
**05** = 5"  
**07** = 7"  
**10** = 10"  
**12** = 12"  
**15** = 15"  
**20** = 20"  
**24** = 24"

# FC5-2580-2632-B 15 R

**O.D. SIZE**

<p><b>FC23 or FC24 - Small end</b>  <b>FC3 - Both Ends O.D.</b>  <b>FC4 - Both Ends O.D.</b>  <b>FC5 - Small End O.D.</b>  <b>FC6 - Large End O.D.</b></p>	<p><b>FC23 or FC24 - Large end</b>  <b>FC5 - Large End O.D.</b>  <b>FC6 - Small End O.D.</b></p>
--	--

### COATING, BOLTS AND GASKET OPTIONS

<i>COATING AND HARDWARE COMBINATIONS</i>								
<i>GASKET MATERIAL</i>	Standard Shop Coat				Epoxy Coated			
	Standard Alloy Hdw.	304 Stainless Steel Hdw.	316 Stainless Steel Hdw.	Electro Galvanized Hdw.	Standard Alloy Hdw.	304 Stainless Steel Hdw.	316 Stainless Steel Hdw.	Electro Galvanized Hdw.
SBR Rubber	R	X	Q	G	E	Y	Z	K
Buna-N Rubber	N	H	J	F	C	P	T	O
EPDM Rubber	S	M	V	W	A	B	D	L

Note: See item listings in catalog section to ensure that desired sizes and options are available.  
 \*See page N-12 for more specific Numbering System of FC3 coupling.



**Ford Meter Box - Pipe Products Division**  
 Pell City, Alabama

# Information

## FC23/FC24 Steel Transition Coupling

- Steel center sleeve
- Ductile iron end rings
- Rated working pressure - 4" - 18" 200 psi, 20" - 24" 150 psi
- Nominal sizes 4" through 24"
- See page N-8

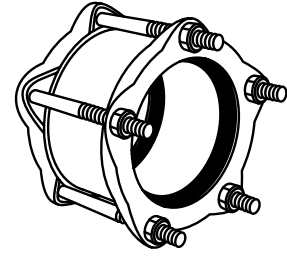

## FC3 Steel Coupling

- Steel center sleeve
- Steel or ductile iron end rings
- Standard gasket specially compounded for water applications
- Nominal sizes 1/2" through 12"
- See page N-12

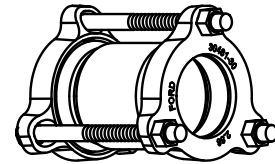

## FC4 Steel Coupling

- Carbon steel center sleeve
- Carbon steel end rings
- Large variety of gasket, hardware and coating options
- Nominal sizes 14" through 60"
- See page N-14

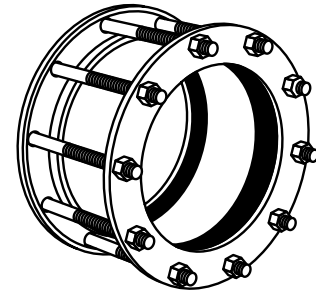

## FC4 Steel End Cap Coupling

- Provides a temporary end or air relief
- Options include a tapped or blind end cap
- Construction and options similar to FC4
- See page N-17

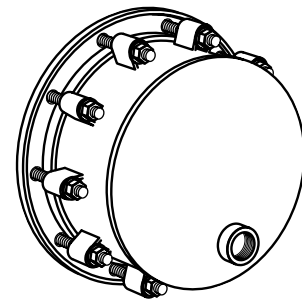

## FC5 Steel Transition Coupling

- Steel center sleeve and end rings
- Maximum transition between pipes is 1" except as listed
- Nominal sizes 14" through 60"
- See page N-18

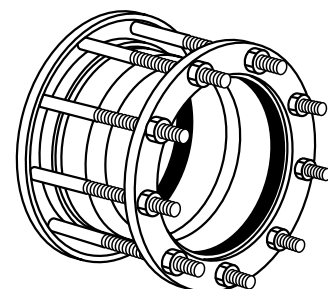

# Information

## FC6 Steel Reducing Coupling

- Steel center sleeve
- Ductile iron or steel end rings
- Connects pipes with diameter variations in excess of 1"
- 150 psi R.W.P. with reduction of two nominal sizes or less
- Nominal sizes 2" through 60"
- See page N-20

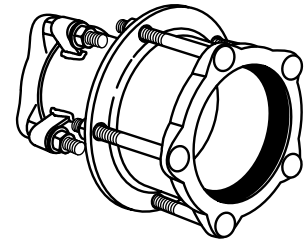

## FCA Steel Flanged Coupling Adapters

- Steel flange and center sleeve
- Ductile iron or steel end rings
- Options include anchor studs and harness assemblies
- Nominal sizes 4" through 48"
- See page N-22

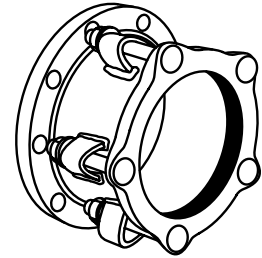

## FDJ Dismantling Joint

- 4" - 12" ductile iron body and end ring (larger sizes are steel)
- Steel adjusting pipe and flange
- Nominal sizes 4" through 36" (larger available)
- See page N-26

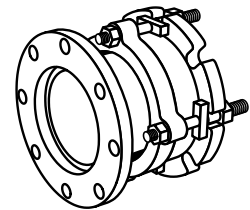

## FEJ Expansion Joint

- Allows maximum of 10" pipe movement
- Nominal sizes 4" through 24"
- Supplied with plain ends for field welding or flanged ends
- See page N-27

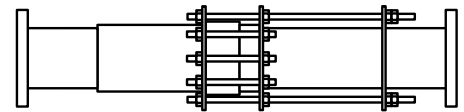

## Ford Restrainer Assemblies

- FR1 - For pipe that cannot be field welded
- FR2 - Requires field welding of steel lug to steel pipe
- FR3 - Used for restraint of steel pipe
- See page N-30

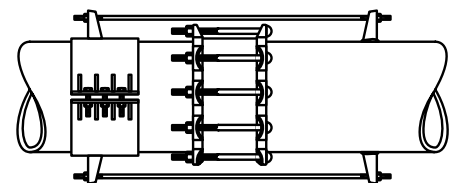

## FWS Weld on Tapping Sleeve

- Specifically designed for steel pipe
- Rounded corners to facilitate a continuous weld stroke
- Nominal sizes 3" through 48"
- See page N-32

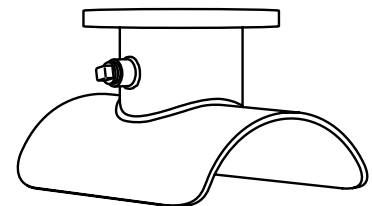

## Custom Fabrications

- Manufactured to meet AWWA C208 standards
- See page N-33

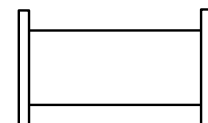

# Material Specification

**Submittal Drawings:** The Ford Meter Box Company will supply, upon request, detailed submittal drawings of any of our pipe products including fabricated steel products identified in this catalog section. These submittal documents include cross sectional drawings of our products as well as detailed material specifications and other information specific to your particular job requirements. Please contact your Ford Meter Box Customer Service Representative for more information.

**General Design Information:** All of the fabricated steel products found in this catalog section are built to meet the requirements of applicable AWWA standards. Some Ford fabricated products are designed and manufactured to fit a specific pipe diameter. In order to accommodate the manufacturing tolerances of various pipeline materials, couplings without an indicated range have a built in tolerance of  $\pm 0.10$ " as measured on the diameter.

<b>Center Sleeve:</b>	1/2" - 60"	Carbon steel per ASTM A36 / minimum yield = 36,000 psi
<b>End Rings:</b>	4" - 24" 14" - 60"	Ductile iron per ASTM A536 Type 65-45-12 AISI 1018-1020 cold rolled or extruded carbon steel / minimum yield = 40,000 psi
<b>Hardware:</b>	1/2" - 60"	STANDARD: Corrosion resistant high strength low alloy steel ( <b>fasteners</b> ) per AWWA C111 and ASTM A242 OPTIONAL: Type 304 stainless steel per ASTM A193 and A194 OPTIONAL: Type 316 stainless steel per ASTM A193 and A194 OPTIONAL: Zinc plated with di-chromate seal (electro-galvanized)
<b>Gaskets:</b>	4" - 60"	STANDARD: Molded or extruded styrene butadiene rubber (SBR) per ASTM D2000 / Maximum recommended operating temperature = 150° F OPTIONAL: Molded or extruded Buna-N per ASTM D2000 Maximum recommended operating temperature = 220° F OPTIONAL: Molded or extruded EPDM per ASTM D2000 Maximum recommended operating temperature = 300° F
<b>Finish:</b>		STANDARD: Black shop coat (excluding FC3 Style) OPTIONAL: Fusion bonded epoxy coating / minimum thickness 10 - 12 mils

Additional hardware, gasket and finish options are available. Please contact the Ford Customer Service Department for more information about these and other options available for fabricated steel products.

# Options for Ford Fabricated Steel Products

## Special Coatings and Linings

The standard coating applied to Ford Fabricated Products is a black, water-based shop coat suitable as an undercoat for many field-applied coatings. The most commonly requested and specified optional coating is epoxy. Our standard epoxy application process is a heat activated fusion bonding of epoxy powder to the fabricated steel part. The coating conforms to the requirements of AWWA C213. Other special primers and coatings are available.



## Pipe Stops

Pipe stops are optional for most Section N coupling products. The stops prevent a coupling from sliding completely onto a piece of pipe. The purpose of these devices is to provide a means to center the coupling over the pipe ends during installation. The use of pipe stops limits the versatility of couplings by preventing the insertion of a pipe section, valves, or other fittings into existing pipelines. The repair of piping joined with couplings built with pipe stops can only be accomplished by cutting and removing a portion of the pipeline.

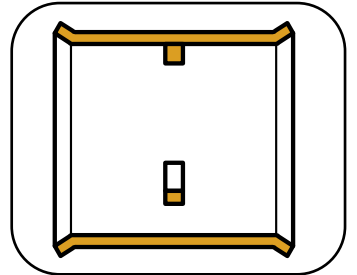

## Anchor Studs

Anchor studs are a common method used to restrain axial pipe movement in couplings. Although most frequently used in applications that include flanged coupling adapters, anchor studs may be incorporated into the design of flexible couplings as well. Anchor studs may not be used with AC pipe or plastic piping material. The illustration shows an example of a typical anchor stud application. Note that the proper installation requires the stud to be assembled by threading through the coupling and into a hole that must be drilled in the pipe.

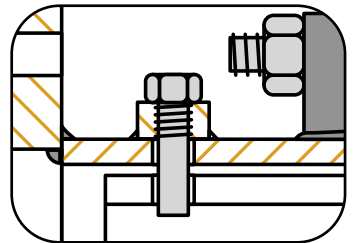

## Fasteners

Standard bolts and nuts shipped with our fabricated steel products are corrosion resistant, high strength low alloy steel that conform to the requirements of AWWA C111 and ASTM A242. When a fabricated steel product will be used in an especially corrosive environment, it may be necessary to use hardware that is more corrosion resistant than standard fasteners. Ford can supply several options for this requirement including Type 304 and Type 316 stainless steel. Another option frequently specified is "Galvanized." The Ford Meter Box Company does not recommend the use of "Hot-Dipped Galvanized" fasteners because the thickness of the coating interferes with the threads of the bolt and nut. The alternative we offer is a steel bolt with electro-deposited zinc plating and a di-chromate seal, commonly referred to in our literature as "Electro-Galvanized."



## FIB Ford Insulating Boot

For applications that require electrical isolation of main line piping from attached couplings, an insulating boot can be supplied with most Section N products. The boot fits over the end of one or both of two plain end pipes to be joined and electrically insulates the pipes from each other and from the attached coupling. Insulating boots add .25" to the pipe outside diameter. Please refer to Ford Catalog section M for details on FIB's through 12". Information about larger sizes can be obtained by calling the Ford Meter Box Company Customer Service Department in Wabash.

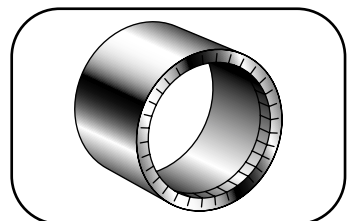

# Ford Transition Couplings

## Style FC23/FC24 - Fabricated Steel Center Sleeve with Ductile Iron End Rings

The extremely versatile Ford FC23 and FC24 Transition Couplings are designed to connect plain end pipes with different OD's for nominal pipe sizes ranging from 4" through 24". FC23 couplings are manufactured using center sleeves with a thickness of 1/4" while FC24 couplings utilize 3/8" thick material for the center sleeve. Each gasket is clearly identified with the pipe OD range that it will accommodate. The FC23 and FC24 couplings are available in a variety of center sleeve lengths including the popular 5, 7, and 10 inch lengths. Longer sleeves are available.

**Finish** - Black shop coat / color coded end rings  
Optional: Fusion bonded epoxy

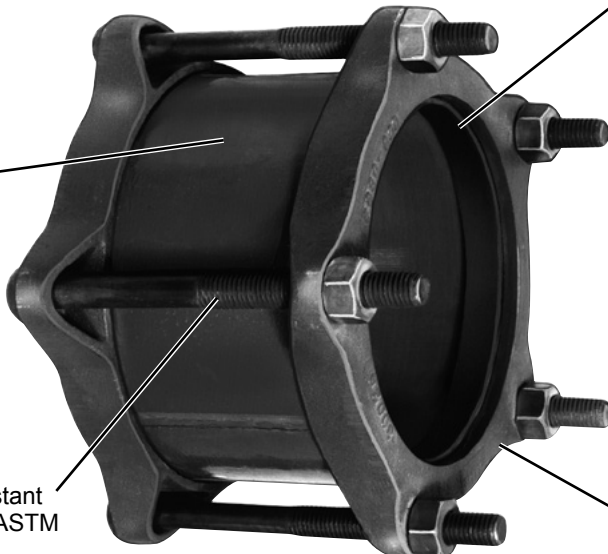

**Center Sleeve** - ASTM A36 Carbon Steel  
FC23 - 1/4" thickness  
FC24 - 3/8" thickness

**Gaskets** - SBR molded rubber  
Optional: - Buna-N  
- EPDM

**End Rings** - Ductile iron per ASTM A536

**Rated Working Pressure** -  
4" - 18" = 200 psi  
20" - 24" = 150 psi

**Bolts and Nuts** - Corrosion resistant high strength low alloy steel per ASTM A242 and AWWA C111  
Optional: -Type 304 stainless steel  
-Type 316 stainless steel  
-Electro-galvanized steel  
-Blue fluorocarbon coating

**Caution: Flexible couplings do not restrain axial pipe movement. Unbalanced forces created by internal water pressure or external forces must be restrained.**

### How to order FC23/FC24 Couplings:

Locate the gasket ranges that accommodate your pipe O.D.s for both coupling ends. Select the desired center sleeve length and use the corresponding catalog number. For coupling lengths, coating and bolt options not listed in the following charts, select the proper catalog number for your pipe O.D.s for both coupling ends and substitute the desired option codes listed below.

## FC23-663-720-10 R

Product Identification: Steel Transition Coupling  
Use FC24 when ordering center sleeve with 3/8" thickness.

Small End (Top range of gasket)

Large End (Top range of gasket)

Center Sleeve Length  
05 = 5"  
07 = 7"  
10 = 10"  
12 = 12"  
15 = 15"  
20 = 20"  
24 = 24"

COATING, HARDWARE AND GASKET OPTIONS				
COATING AND HDWR. COMBINATIONS				
GASKET MATERIAL	Standard Alloy Hdwr.	304 Stainless Steel Hdwr.	316 Stainless Steel Hdwr.	Electro Galvanized Hdwr.
<b>Standard Shop Coat</b>				
SBR Rubber	R	X	Q	G
Buna-N Rubber	N	H	J	F
EPDM Rubber	S	M	V	W
<b>Epoxy Coated</b>				
SBR Rubber	E	Y	Z	K
Buna-N Rubber	C	P	T	O
EPDM Rubber	A	B	D	L
Note: See item listings in catalog section to assure that desired sizes and options are available				



# Ford Transition Couplings

## Style FC23/FC24 - Fabricated Steel Center Sleeve with Ductile Iron End Rings (4" through 24")

NOM. PIPE SIZE	1ST END GASKET RANGE	2ND END GASKET RANGE	LENGTH OF CENTER SLEEVE	CATALOG NUMBER	NUMBER OF BOLTS	APPROX. WT. LBS.
4"	4.00	4.00	5"	FC23-400-400-05R	3	17
	4.00	4.00	7"	FC23-400-400-07R	3	22
	4.00	4.00	10"	FC23-400-400-10R	3	28
	4.00	4.50	5"	FC23-400-450-05R	3	17
	4.00	4.50	7"	FC23-400-450-07R	3	22
	4.00	4.50	10"	FC23-400-450-10R	3	28
	4.00	4.80-5.14	5"	FC23-400-514-05R	3	17
	4.00	4.80-5.14	7"	FC23-400-514-07R	3	22
	4.00	4.80-5.14	10"	FC23-400-514-10R	3	28
	4.00	5.15-5.57	5"	FC23-400-557-05R	3	17
	4.00	5.15-5.57	7"	FC23-400-557-07R	3	22
	4.00	5.15-5.57	10"	FC23-400-557-10R	3	28
	4.50	4.50	5"	FC23-450-450-05R	3	17
	4.50	4.50	7"	FC23-450-450-07R	3	22
	4.50	4.50	10"	FC23-450-450-10R	3	28
	4.50	4.80-5.14	5"	FC23-450-514-05R	3	17
	4.50	4.80-5.14	7"	FC23-450-514-07R	3	22
	4.50	4.80-5.14	10"	FC23-450-514-10R	3	28
	4.50	5.15-5.57	5"	FC23-450-557-05R	3	17
	4.50	5.15-5.57	7"	FC23-450-557-07R	3	22
	4.50	5.15-5.57	10"	FC23-450-557-10R	3	28
	4.80-5.14	4.80-5.14	5"	FC23-514-514-05R	3	17
	4.80-5.14	4.80-5.14	7"	FC23-514-514-07R	3	22
	4.80-5.14	4.80-5.14	10"	FC23-514-514-10R	3	28
	4.80-5.14	5.15-5.57	5"	FC23-514-557-05R	3	17
	4.80-5.14	5.15-5.57	7"	FC23-514-557-07R	3	22
	4.80-5.14	5.15-5.57	10"	FC23-514-557-10R	3	28
	5.15-5.57	5.15-5.57	5"	FC23-557-557-05R	3	17
	5.15-5.57	5.15-5.57	7"	FC23-557-557-07R	3	22
	5.15-5.57	5.15-5.57	10"	FC23-557-557-10R	3	28
6"	6.00	6.00	5"	FC23-600-600-05R	4	19
	6.00	6.00	7"	FC23-600-600-07R	4	24
	6.00	6.00	10"	FC23-600-600-10R	4	29
	6.00	6.63	5"	FC23-600-663-05R	4	19
	6.00	6.63	7"	FC23-600-663-07R	4	24
	6.00	6.63	10"	FC23-600-663-10R	4	29
	6.00	6.90-7.20	5"	FC23-600-720-05R	4	19
	6.00	6.90-7.20	7"	FC23-600-720-07R	4	24
	6.00	6.90-7.20	10"	FC23-600-720-10R	4	29
	6.00	7.21-7.56	5"	FC23-600-756-05R	4	19
	6.00	7.21-7.56	7"	FC23-600-756-07R	4	24
	6.00	7.21-7.56	10"	FC23-600-756-10R	4	29
	6.63	6.63	5"	FC23-663-663-05R	4	19
	6.63	6.63	7"	FC23-663-663-07R	4	24
	6.63	6.63	10"	FC23-663-663-10R	4	29
	6.63	6.90-7.20	5"	FC23-663-720-05R	4	19
	6.63	6.90-7.20	7"	FC23-663-720-07R	4	24
	6.63	6.90-7.20	10"	FC23-663-720-10R	4	29
	6.63	7.21-7.56	5"	FC23-663-756-05R	4	19
	6.63	7.21-7.56	7"	FC23-663-756-07R	4	24
	6.63	7.21-7.56	10"	FC23-663-756-10R	4	29
	6.90-7.20	6.90-7.20	5"	FC23-720-720-05R	4	19
	6.90-7.20	6.90-7.20	7"	FC23-720-720-07R	4	24
	6.90-7.20	6.90-7.20	10"	FC23-720-720-10R	4	29
	6.90-7.20	7.21-7.56	5"	FC23-720-756-05R	4	19
	6.90-7.20	7.21-7.56	7"	FC23-720-756-07R	4	24
	6.90-7.20	7.21-7.56	10"	FC23-720-756-10R	4	29
	7.21-7.56	7.21-7.56	5"	FC23-756-756-05R	4	19
	7.21-7.56	7.21-7.56	7"	FC23-756-756-07R	4	24
	7.21-7.56	7.21-7.56	10"	FC23-756-756-10R	4	29

Additional sizes on following page.

# Ford Transition Couplings

Style FC23/FC24 - Fabricated Steel Center Sleeve with Ductile Iron End Rings (4" through 24") *Continued . . .*

NOM. PIPE SIZE	1ST END GASKET RANGE	2ND END GASKET RANGE	LENGTH OF CENTER SLEEVE	CATALOG NUMBER	NUMBER OF BOLTS	APPROX. WT. LBS.
8"	8.00	8.00	5"	FC23-800-800-05R	5	26
	8.00	8.00	7"	FC23-800-800-07R	5	32
	8.00	8.00	10"	FC23-800-800-10R	5	39
	8.00	8.63	5"	FC23-800-863-05R	5	26
	8.00	8.63	7"	FC23-800-863-07R	5	32
	8.00	8.63	10"	FC23-800-863-10R	5	39
	8.00	9.05-9.40	5"	FC23-800-940-05R	5	26
	8.00	9.05-9.40	7"	FC23-800-940-07R	5	32
	8.00	9.05-9.40	10"	FC23-800-940-10R	5	39
	8.00	9.40-9.74	5"	FC23-800-974-05R	5	26
	8.00	9.40-9.74	7"	FC23-800-974-07R	5	32
	8.00	9.40-9.74	10"	FC23-800-974-10R	5	39
	8.63	8.63	5"	FC23-863-863-05R	5	26
	8.63	8.63	7"	FC23-863-863-07R	5	32
	8.63	8.63	10"	FC23-863-863-10R	5	39
	8.63	9.05-9.40	5"	FC23-863-940-05R	5	26
	8.63	9.05-9.40	7"	FC23-863-940-07R	5	32
	8.63	9.05-9.40	10"	FC23-863-940-10R	5	39
	8.63	9.40-9.74	5"	FC23-863-974-05R	5	26
	8.63	9.40-9.74	7"	FC23-863-974-07R	5	32
	8.63	9.40-9.74	10"	FC23-863-974-10R	5	39
	9.05-9.40	9.05-9.40	5"	FC23-940-940-05R	5	26
	9.05-9.40	9.05-9.40	7"	FC23-940-940-07R	5	32
	9.05-9.40	9.05-9.40	10"	FC23-940-940-10R	5	39
	9.05-9.40	9.40-9.74	5"	FC23-940-974-05R	5	26
	9.05-9.40	9.40-9.74	7"	FC23-940-974-07R	5	32
	9.05-9.40	9.40-9.74	10"	FC23-940-974-10R	5	39
	9.40-9.74	9.40-9.74	5"	FC23-974-974-05R	5	26
	9.40-9.74	9.40-9.74	7"	FC23-974-974-07R	5	32
	9.40-9.74	9.40-9.74	10"	FC23-974-974-10R	5	39
10"	10.75	10.75	5"	FC23-1075-1075-05R	6	33
	10.75	10.75	7"	FC23-1075-1075-07R	6	40
	10.75	10.75	10"	FC23-1075-1075-10R	6	49
	10.75	11.10-11.40	5"	FC23-1075-1140-05R	6	33
	10.75	11.10-11.40	7"	FC23-1075-1140-07R	6	40
	10.75	11.10-11.40	10"	FC23-1075-1140-10R	6	49
	10.75	11.42-11.77	5"	FC23-1075-1177-05R	6	33
	10.75	11.42-11.77	7"	FC23-1075-1177-07R	6	40
	10.75	11.42-11.77	10"	FC23-1075-1177-10R	6	49
	10.75	11.77-12.12	5"	FC23-1075-1212-05R	6	33
	10.75	11.77-12.12	7"	FC23-1075-1212-07R	6	40
	10.75	11.77-12.12	10"	FC23-1075-1212-10R	6	49
	11.10-11.40	11.10-11.40	5"	FC23-1140-1140-05R	6	33
	11.10-11.40	11.10-11.40	7"	FC23-1140-1140-07R	6	40
	11.10-11.40	11.10-11.40	10"	FC23-1140-1140-10R	6	49
	11.10-11.40	11.42-11.77	5"	FC23-1140-1177-05R	6	33
	11.10-11.40	11.42-11.77	7"	FC23-1140-1177-07R	6	40
	11.10-11.40	11.42-11.77	10"	FC23-1140-1177-10R	6	49
	11.10-11.40	11.77-12.12	5"	FC23-1140-1212-05R	6	33
	11.10-11.40	11.77-12.12	7"	FC23-1140-1212-07R	6	40
	11.10-11.40	11.77-12.12	10"	FC23-1140-1212-10R	6	49
	11.42-11.77	11.42-11.77	5"	FC23-1177-1177-05R	6	33
	11.42-11.77	11.42-11.77	7"	FC23-1177-1177-07R	6	40
	11.42-11.77	11.42-11.77	10"	FC23-1177-1177-10R	6	49
	11.42-11.77	11.77-12.12	5"	FC23-1177-1212-05R	6	33
	11.42-11.77	11.77-12.12	7"	FC23-1177-1212-07R	6	40
	11.42-11.77	11.77-12.12	10"	FC23-1177-1212-10R	6	49
	11.77-12.12	11.77-12.12	5"	FC23-1212-1212-05R	6	33
	11.77-12.12	11.77-12.12	7"	FC23-1212-1212-07R	6	40
	11.77-12.12	11.77-12.12	10"	FC23-1212-1212-10R	6	49

# Ford Transition Couplings

## Style FC23/FC24 - Fabricated Steel Center Sleeve with Ductile Iron End Rings (4" through 24") *Continued . . .*

NOM. PIPE SIZE	1ST END GASKET RANGE	2ND END GASKET RANGE	LENGTH OF CENTER SLEEVE	CATALOG NUMBER	NUMBER OF BOLTS	APPROX. Wt. LBS.	
12"	12.75	12.75	5"	FC23-1275-1275-05R	7	42	
	12.75	12.75	7"	FC23-1275-1275-07R	7	51	
	12.75	12.75	10"	FC23-1275-1275-10R	7	61	
	12.75	13.20-13.50	5"	FC23-1275-1350-05R	7	41	
	12.75	13.20-13.50	7"	FC23-1275-1350-07R	7	49	
	12.75	13.20-13.50	10"	FC23-1275-1350-10R	7	59	
	12.75	13.69-14.04	5"	FC23-1275-1404-05R	7	42	
	12.75	13.69-14.04	7"	FC23-1275-1404-07R	7	51	
	12.75	13.69-14.04	10"	FC23-1275-1404-10R	7	61	
	12.75	14.03-14.38	5"	FC23-1275-1438-05R	7	42	
	12.75	14.03-14.38	7"	FC23-1275-1438-07R	7	51	
	12.75	14.03-14.38	10"	FC23-1275-1438-10R	7	61	
	13.20-13.50	13.20-13.50	5"	FC23-1350-1350-05R	7	39	
	13.20-13.50	13.20-13.50	7"	FC23-1350-1350-07R	7	48	
	13.20-13.50	13.20-13.50	10"	FC23-1350-1350-10R	7	57	
	13.20-13.50	13.69-14.04	5"	FC23-1350-1404-05R	7	42	
	13.20-13.50	13.69-14.04	7"	FC23-1350-1404-07R	7	51	
	13.20-13.50	13.69-14.04	10"	FC23-1350-1404-10R	7	61	
	13.20-13.50	14.03-14.38	5"	FC23-1350-1438-05R	7	41	
	13.20-13.50	14.03-14.38	7"	FC23-1350-1438-07R	7	50	
	13.20-13.50	14.03-14.38	10"	FC23-1350-1438-10R	7	60	
	13.69-14.04	13.69-14.04	5"	FC23-1404-1404-05R	7	40	
	13.69-14.04	13.69-14.04	7"	FC23-1404-1404-07R	7	49	
	13.69-14.04	13.69-14.04	10"	FC23-1404-1404-10R	7	59	
	13.69-14.04	14.03-14.38	5"	FC23-1404-1438-05R	7	39	
	13.69-14.04	14.03-14.38	7"	FC23-1404-1438-07R	7	48	
	13.69-14.04	14.03-14.38	10"	FC23-1404-1438-10R	7	58	
	14.03-14.38	14.03-14.38	5"	FC23-1438-1438-05R	7	39	
14.03-14.38	14.03-14.38	7"	FC23-1438-1438-07R	7	49		
14.03-14.38	14.03-14.38	10"	FC23-1438-1438-10R	7	58		
14"	15.30-15.70	15.30-15.70	5"	FC23-1570-1570-05R	9	66	
	15.30-15.70	15.30-15.70	7"	FC23-1570-1570-07R	9	71	
	15.30-15.70	15.30-15.70	10"	FC23-1570-1570-10R	9	85	
	15.30-15.70	16.00-16.35	5"	FC23-1570-1635-05R	9	58	
	15.30-15.70	16.00-16.35	7"	FC23-1570-1635-07R	9	68	
	15.30-15.70	16.00-16.35	10"	FC23-1570-1635-10R	9	82	
	15.30-15.70	16.40-16.88	5"	FC23-1570-1688-05R	9	59	
	15.30-15.70	16.40-16.88	7"	FC23-1570-1688-07R	9	70	
	15.30-15.70	16.40-16.88	10"	FC23-1570-1688-10R	9	83	
	16.00-16.35	16.00-16.35	5"	FC23-1635-1635-05R	9	55	
	16.00-16.35	16.00-16.35	7"	FC23-1635-1635-07R	9	66	
	16.00-16.35	16.00-16.35	10"	FC23-1635-1635-10R	9	80	
	16.00-16.35	16.40-16.88	5"	FC23-1635-1688-05R	9	56	
	16.00-16.35	16.40-16.88	7"	FC23-1635-1688-07R	9	67	
	16.00-16.35	16.40-16.88	10"	FC23-1635-1688-10R	9	80	
	16.40-16.88	16.40-16.88	5"	FC23-1688-1688-05R	9	57	
	16.40-16.88	16.40-16.88	7"	FC23-1688-1688-07R	9	68	
	16.40-16.88	16.40-16.88	10"	FC23-1688-1688-10R	9	81	
	16"	17.40-17.80	17.40-17.80	5"	FC23-1780-1780-05R	10	76
		17.40-17.80	17.40-17.80	7"	FC23-1780-1780-07R	10	88
17.40-17.80		17.40-17.80	10"	FC23-1780-1780-10R	10	102	
17.40-17.80		18.45-18.97	5"	FC23-1780-1897-05R	10	71	
17.40-17.80		18.45-18.97	7"	FC23-1780-1897-07R	10	83	
17.40-17.80		18.45-18.97	10"	FC23-1780-1897-10R	10	98	
17.40-17.80		18.90-19.20	5"	FC23-1780-1920-05R	10	73	
17.40-17.80		18.90-19.20	7"	FC23-1780-1920-07R	10	85	
17.40-17.80		18.90-19.20	10"	FC23-1780-1920-10R	10	99	
18.45-18.97		18.45-18.97	5"	FC23-1897-1897-05R	10	72	
18.45-18.97		18.45-18.97	7"	FC23-1897-1897-07R	10	84	
18.45-18.97		18.45-18.97	10"	FC23-1897-1897-10R	10	98	
18.45-18.97		18.90-19.20	5"	FC23-1897-1920-05R	10	71	
18.45-18.97		18.90-19.20	7"	FC23-1897-1920-07R	10	84	
18.45-18.97		18.90-19.20	10"	FC23-1897-1920-10R	10	98	
18.90-19.20		18.90-19.20	5"	FC23-1920-1920-05R	10	71	
18.90-19.20		18.90-19.20	7"	FC23-1920-1920-07R	10	83	
18.90-19.20		18.90-19.20	10"	FC23-1920-1920-10R	10	97	
18"	19.50-20.00	19.50-20.00	7"	FC23-2000-2000-07R	11	88	
	19.50-20.00	19.50-20.00	10"	FC23-2000-2000-10R	11	103	
20"	21.60-22.06	21.60-22.06	7"	FC23-2206-2206-07R	12	99	
	21.60-22.06	21.60-22.06	10"	FC23-2206-2206-10R	12	119	
24"	25.80-26.32	25.80-26.32	7"	FC23-2632-2632-07R	14	168	
	25.80-26.32	25.80-26.32	10"	FC23-2632-2632-10R	14	185	

See page 2 index for larger couplings.

# Ford Standard Steel Couplings

## Style FC3 (1/2" through 12")

The FC3 coupling is manufactured in standard steel sizes with a steel center sleeve and ductile iron end rings. The FC3, in its standard configuration, may be used for water as well as natural gas applications.

**Finish - Red fusion-bonded epoxy on end rings**  
**Black fusion-bonded epoxy on center sleeve with Armorguard e-coat undercoat**

**End Rings** - Ductile iron (Grade 65-45-12) per ASTM A536

**Center Sleeve** - Steel per ASTM A1011

**Gaskets** - Buna-N (NBR)  
 Optional: - Armor-tip gasket (-ATG)

**Bolts and Nuts** - High strength low alloy steel per ASTM A242  
 Optional stainless steel or blue fluorocarbon-coated hardware

**Caution: Couplings do not restrain axial pipe movement.**  
**Unbalanced forces created by internal water pressure or external forces must be restrained.**

### How to order FC3 couplings:

Use catalog numbers from the next page. For example, an FC3 steel coupling with a center sleeve length of 7" for pipe with an O.D. of 2.88 would be an FC3-288-7.

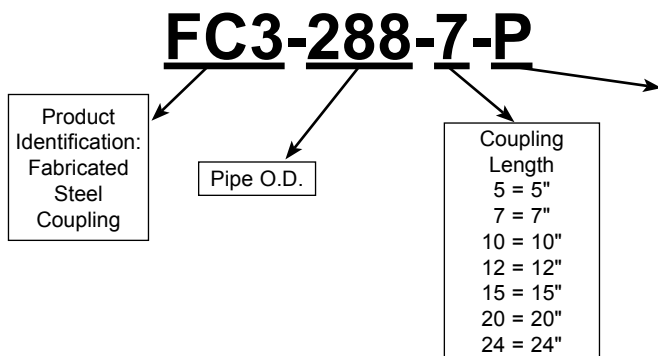

COATING, HARDWARE AND GASKET OPTIONS				
EPOXY COATED				
COATING AND HDWR. COMBINATIONS				
GASKET MATERIAL	Standard Alloy Hdw.	304 Stainless Steel Hdw.	316 Stainless Steel Hdw.	Electro-Galvanized Hdw.
Buna-N Rubber	(no suffix)	P	T	O

# Ford Standard Steel Couplings

Style FC3

## Style FC3 Standard Steel Couplings - 1/2" through 12"

NOM. PIPE SIZE	PIPE O.D.	SLEEVE THICKNESS & LENGTH	CATALOG NUMBER	NUMBER OF BOLTS	BOLT DIA. & LENGTH	APPROX. WT. LBS.
1/2"	.84	.120x5"	FC3-084-5	2	1/2"x7"	2
		.120x7"	FC3-084-7	2	1/2"x9"	2
3/4"	1.05	.120x5"	FC3-105-5	2	1/2"x7"	2
		.120x7"	FC3-105-7	2	1/2"x9"	3
		.120x12"	FC3-105-12	2	1/2"x14"	3
1"	1.32	.120x5"	FC3-132-5	2	1/2"x7"	3
		.120x7"	FC3-132-7	2	1/2"x9"	3
		.120x12"	FC3-132-12	2	1/2"x14"	4
1-1/4"	1.66	.134x5"	FC3-166-5	2	1/2"x7"	4
		.134x7"	FC3-166-7	2	1/2"x9"	4
		.134x12"	FC3-166-12	2	1/2"x14"	5
1-1/2"	1.90	.134x5"	FC3-190-5	2	1/2"x7"	4
		.134x7"	FC3-190-7	2	1/2"x9"	5
		.134x12"	FC3-190-12	2	1/2"x14"	7
2"	2.38	.156x5"	FC3-238-5	2	5/8"x8"	7
		.156x5"	FC3-238-5-H	3	5/8"x8"	10
		.156x7"	FC3-238-7	2	5/8"x10-1/2"	10
		.156x7"	FC3-238-7-H	3	5/8"x10-1/2"	12
		.156x12"	FC3-238-12	2	5/8"x15"	13
2-1/2"	2.88	.156x12"	FC3-238-12-H	3	5/8"x15"	14
		.156x5"	FC3-288-5	3	5/8"x8"	10
		.156x7"	FC3-288-7	3	5/8"x10-1/2"	11
		.156x12"	FC3-288-12	3	5/8"x15"	14
		.156x24"	FC3-288-24	3	5/8"x27-3/8"	24
3"	3.50	.203x5"	FC3-350-5	4	5/8"x8"	16
		.203x7"	FC3-350-7	4	5/8"x10-1/2"	17
		.203x12"	FC3-350-12	4	5/8"x15"	26
		.203x24"	FC3-350-24	4	5/8"x27-3/8"	35
4"	4.50	.203x5"	FC3-450-5	4	5/8"x8"	16
		.203x7"	FC3-450-7	4	5/8"x10-1/2"	17
		.203x12"	FC3-450-12	4	5/8"x15"	27
		.203x16"	FC3-450-16	4	5/8"x20"	31
	4.80	.203x24"	FC3-450-24	4	5/8"x27-3/8"	38
		.203x5"	FC3-480-5	4	5/8"x9"	16
6"	6.63	.203x7"	FC3-480-7	4	5/8"x11"	17
		.203x12"	FC3-480-12	4	5/8"x15"	27
		.250x5"	FC3-663-5	6	5/8"x8"	25
		.250x7"	FC3-663-7	6	5/8"x10-1/2"	31
	6.90	.250x12"	FC3-663-12	6	5/8"x15"	39
		.250x16"	FC3-663-16	6	5/8"x20"	50
		.250x24"	FC3-663-24	6	5/8"x27-3/8"	65
		.250x5"	FC3-690-5	6	5/8"x9"	25
8"	8.63	.250x16"	FC3-690-16	6	5/8"x19"	50
		.250x5"	FC3-863-5	6	5/8"x8"	34
		.250x7"	FC3-863-7	6	5/8"x10-1/2"	41
		.250x12"	FC3-863-12	6	5/8"x15"	51
		.250x16"	FC3-863-16	6	5/8"x20"	63
10"	10.75	.250x24"	FC3-863-24	6	5/8"x27-3/8"	78
12"	12.75	.250x7"	FC3-1075-7	8	5/8"x11"	49
		.250x5"	FC3-1275-5	8	5/8"x9"	47
		.250x16"	FC3-1275-16	8	5/8"x19"	88

"-H" indicates three bolt style

**Note:** Larger sizes are detailed as style FC4 on pages 15 and 16.

# Ford Steel Couplings

## Style FC4 (14" through 60")

The Ford FC4 Steel Coupling is an all steel coupling designed to connect various types of plain end pipe with the same O.D. and is available for pipe sizes up to a maximum nominal diameter of 60 inches. Design and performance characteristics of fabricated steel couplings are specified in AWWA Standard C219. The Style FC4 Coupling is available in a variety of center sleeve lengths and thicknesses.



**Bolts and Nuts** - High strength low alloy steel ASTM A242 and AWWA C111  
 Optional: - Type 304 stainless steel  
 - Type 316 stainless steel  
 - Electro-galvanized steel  
 - Blue Fluorocarbon coating

**Center Sleeve** - ASTM A36 carbon Steel

**Finish** - Black shop coat  
 Optional: - Epoxy coating

**Gaskets** - SBR Rubber  
 Optional: - Buna-N  
 - EPDM

**End Rings** - AISI 1018-1020 cold rolled or extruded carbon steel

**Caution: Flexible couplings do not restrain axial pipe movement. Unbalanced forces created by internal water pressure or external forces must be restrained. Restrained couplings using Uni-Flange restraints can be found in Catalog Section U. Contact factory for details.**

### How to order FC4 couplings:

Our code system is used to designate the part number. Each code determines how the coupling will be manufactured. The coupling center sleeve thickness and length is generally determined by the pipe O.D. and the working pressure. Ford will manufacture FC4 couplings to your specifications using the material and dimensional parameters listed below. **Before ordering a special pipe O.D., make sure your O.D. is not listed in the table on page N-15 or N-16.**

The example shown below is an FC4-5140-B10R. This coupling is made to fit a pipe with an O.D. of 51.40 inches. It is manufactured using a 3/8" by 10" steel center sleeve and standard bolts, and is finished with a standard shop coat. For coupling length, coating and bolt options not listed on the following charts, select the proper catalog number to accommodate your pipe O.D. and substitute the desired option codes listed below.

FC4-5140-B 10 R

Product Identification:  
Fabricated Steel Coupling

Pipe O.D.

Center Sleeve Thickness  
A = 1/4" Steel  
B = 3/8" Steel

Coupling Length  
05 = 5"  
07 = 7"  
10 = 10"  
12 = 12"  
15 = 15"  
20 = 20"  
24 = 24"

COATING, HARDWARE AND GASKET OPTIONS				
COATING AND HDWR. COMBINATIONS				
GASKET MATERIAL	Standard Alloy Hdwr.	304 Stainless Steel Hdwr.	316 Stainless Steel Hdwr.	Electro Galvanized Hdwr.
<b>Standard Shop Coat</b>				
SBR Rubber	R	X	Q	G
Buna-N Rubber	N	H	J	F
EPDM Rubber	S	M	V	W
<b>Epoxy Coated</b>				
SBR Rubber	E	Y	Z	K
Buna-N Rubber	C	P	T	O
EPDM Rubber	A	B	D	L

Note: See item listings in catalog section to assure that desired sizes and options are available

# Ford Steel Couplings

## Style FC4 (14" through 60")

*Listed below are common sizes of FC4 couplings.*

If your pipe O.D. is not in the listed ranges, insert the exact O.D. into the code system to create your own catalog number (see the previous page).

NOM. PIPE SIZE	PIPE O.D.	SLEEVE THICKNESS & LENGTH	CATALOG NUMBER	RATED WORKING PRESSURE	NUMBER OF BOLTS	APPROX. WT. LBS.
14"	14.00	1/4" x 5"	FC4-1400-A05R	472	9	70
	14.00	1/4" x 7"	FC4-1400-A07R	472	9	75
	14.00	1/4" x 10"	FC4-1400-A10R	472	9	85
	15.30	1/4" x 5"	FC4-1530-A05R	434	9	75
	15.30	1/4" x 7"	FC4-1530-A07R	434	9	80
	15.30	3/8" x 7"	FC4-1530-B07R	592	9	92
	15.30	1/4" x 10"	FC4-1530-A10R	434	9	91
	15.30	3/8" x 10"	FC4-1530-B10R	592	9	109
	15.65	3/8" x 7"	FC4-1565-B07R	583	9	92
15.65	3/8" x 10"	FC4-1565-B10R	583	9	109	
16"	16.00	1/4" x 5"	FC4-1600-A05R	416	10	78
	16.00	1/4" x 7"	FC4-1600-A07R	416	10	83
	16.00	1/4" x 10"	FC4-1600-A10R	416	10	96
	17.40	1/4" x 5"	FC4-1740-A05R	385	10	84
	17.40	1/4" x 7"	FC4-1740-A07R	385	10	89
	17.40	3/8" x 7"	FC4-1740-B07R	567	10	103
	17.40	1/4" x 10"	FC4-1740-A10R	385	10	102
	17.40	3/8" x 10"	FC4-1740-B10R	567	10	122
	17.80	3/8" x 7"	FC4-1780-B07R	540	10	103
17.80	1/4" x 7"	FC4-1780-A07R	372	10	92	
18"	18.00	1/4" x 5"	FC4-1800-A05R	373	11	89
	18.00	1/4" x 7"	FC4-1800-A07R	373	11	94
	18.00	1/4" x 10"	FC4-1800-A10R	373	11	107
	18.80	3/8" x 7"	FC4-1880-B07R	508	11	112
	18.80	1/4" x 7"	FC4-1880-A07R	355	11	100
	19.50	1/4" x 5"	FC4-1950-A05R	345	11	94
	19.50	1/4" x 7"	FC4-1950-A07R	345	11	99
	19.50	3/8" x 7"	FC4-1950-B07R	512	11	115
	19.50	1/4" x 10"	FC4-1950-A10R	345	11	114
19.50	3/8" x 10"	FC4-1950-B10R	512	11	136	
19.92	3/8" x 7"	FC4-1992-B07R	500	11	115	
19.92	1/4" x 7"	FC4-1992-A07R	337	11	104	
20"	20.00	1/4" x 7"	FC4-2000-A07R	337	12	101
	20.00	1/4" x 10"	FC4-2000-A10R	337	12	116
	21.60	1/4" x 7"	FC4-2160-A07R	313	12	107
	21.60	3/8" x 7"	FC4-2160-B07R	463	12	125
	21.60	1/4" x 10"	FC4-2160-A10R	313	12	124
	21.60	3/8" x 10"	FC4-2160-B10R	463	12	148
	22.06	3/8" x 7"	FC4-2206-B07R	456	12	125
22.06	1/4" x 7"	FC4-2206-A07R	307	12	110	
24"	24.00	1/4" x 7"	FC4-2400-A07R	283	14	119
	24.00	1/4" x 10"	FC4-2400-A10R	283	14	137
	25.80	1/4" x 7"	FC4-2580-A07R	264	14	127
	25.80	3/8" x 7"	FC4-2580-B07R	392	14	148
	25.80	1/4" x 10"	FC4-2580-A10R	264	14	146
	25.80	3/8" x 10"	FC4-2580-B10R	392	14	176
	26.32	3/8" x 7"	FC4-2632-B07R	377	14	148
26.32	1/4" x 7"	FC4-2632-A07R	250	14	135	

# Ford Steel Couplings

Style FC4 (14" through 60") *Continued . . .*

**Listed below are common sizes of FC4 couplings.**

If your pipe O.D. is not listed, insert the exact O.D. into the code system to create your own catalog number (see page 14).

NOM. PIPE SIZE	PIPE O.D.	SLEEVE THICKNESS & LENGTH	CATALOG NUMBER	RATED WORKING PRESSURE	NUMBER OF BOLTS	APPROX. WT. LBS.
30"	30.00	1/4" x 7"	FC4-3000-A07R	246	16	135
	30.00	3/8" x 7"	FC4-3000-B07R	361	16	159
	30.00	1/4" x 10"	FC4-3000-A10R	246	16	157
	30.00	3/8" x 10"	FC4-3000-B10R	361	16	189
	32.00	1/4" x 7"	FC4-3200-A07R	230	16	143
	32.00	3/8" x 7"	FC4-3200-B07R	343	16	166
	32.00	1/4" x 10"	FC4-3200-A10R	230	16	166
	32.00	3/8" x 10"	FC4-3200-B10R	343	16	201
36"	36.00	1/4" x 7"	FC4-3600-A07R	205	18	158
	36.00	3/8" x 7"	FC4-3600-B07R	306	18	190
	36.00	1/4" x 10"	FC4-3600-A10R	205	18	186
	36.00	3/8" x 10"	FC4-3600-B10R	306	18	229
	38.30	1/4" x 7"	FC4-3830-A07R	193	18	166
	38.30	3/8" x 7"	FC4-3830-B07R	289	18	226
	38.30	1/4" x 10"	FC4-3830-A10R	193	18	196
	38.30	3/8" x 10"	FC4-3830-B10R	289	18	267
42"	42.00	3/8" x 7"	FC4-4200-B07R	263	20	257
	42.00	3/8" x 10"	FC4-4200-B10R	263	20	302
	44.50	3/8" x 7"	FC4-4450-B07R	250	20	271
	44.50	3/8" x 10"	FC4-4450-B10R	250	20	318
48"	48.00	3/8" x 7"	FC4-4800-B07R	231	22	294
	48.00	3/8" x 10"	FC4-4800-B10R	231	22	345
	49.00	3/8" x 7"	FC4-4900-B07R	226	22	300
	49.00	3/8" x 10"	FC4-4900-B10R	226	22	351
	50.80	3/8" x 7"	FC4-5080-B07R	220	22	309
	50.80	3/8" x 10"	FC4-5080-B10R	220	22	363
54"	54.00	3/8" x 7"	FC4-5400-B07R	213	24	333
	54.00	3/8" x 10"	FC4-5400-B10R	213	24	391
	55.00	3/8" x 7"	FC4-5500-B07R	210	24	339
	55.00	3/8" x 10"	FC4-5500-B10R	210	24	398
	57.10	3/8" x 7"	FC4-5710-B07R	200	24	350
	57.10	3/8" x 10"	FC4-5710-B10R	200	24	411
	57.56	3/8" x 7"	FC4-5756-B07R	200	24	353
	57.56	3/8" x 10"	FC4-5756-B10R	200	24	414
	57.80	3/8" x 7"	FC4-5780-B07R	200	24	354
	57.80	3/8" x 10"	FC4-5780-B10R	200	24	415
60"	60.00	3/8" x 7"	FC4-6000-B07R	200	26	373
	60.00	3/8" x 10"	FC4-6000-B10R	200	26	437
	61.00	3/8" x 7"	FC4-6100-B07R	200	26	378
	61.00	3/8" x 10"	FC4-6100-B10R	200	26	444
	61.61	3/8" x 7"	FC4-6161-B07R	200	26	382
	61.61	3/8" x 10"	FC4-6161-B10R	200	26	447
	63.40	3/8" x 7"	FC4-6340-B07R	200	26	391
	63.40	3/8" x 10"	FC4-6340-B10R	200	26	459



# Ford Steel End Cap Couplings

## Style FC4 – with Tapped or Untapped End Cap

The typical use of an FC4 End Cap Coupling is to provide a temporary end or air relief for a pipeline. The end cap is welded to the center sleeve and can be manufactured with a 2" female iron pipe tap if specified. Tapped end cap couplings are supplied less plug but a plug is available upon request. If a smaller end cap coupling is required, refer to cast couplings listed in catalog section M.

End cap couplings require thrust restraint to prevent the coupling from blowing off of the pipe end. Ford can manufacture the Style FC4 End Cap Coupling with anchor studs or with restrainer assemblies to meet this requirement.

**Bolts and Nuts** - High strength low alloy steel ASTM A242 and AWWA C111

- Optional:
- Type 304 stainless steel
  - Type 316 stainless steel
  - Electro-galvanized steel
  - Blue Fluorocarbon coating

**Gasket** - SBR Rubber

- Optional:
- Buna-N
  - EPDM

**Center Sleeve** - ASTM A36 carbon steel

**End Ring** - AISI 1018-1020 cold rolled, or extruded carbon steel



**Standard Location**  
Optional: Center location

**Finish** - Black shop coat  
Optional: - Fusion bonded epoxy

**Caution: Proper installation of end cap couplings must include the use of a thrust restraint device.**

*Listed below are common sizes of FC4 couplings.*

NOM. PIPE SIZE	PIPE O.D.	SLEEVE THICKNESS & LENGTH	CATALOG NUMBER	RATED WORKING PRESSURE	NUMBER OF BOLTS	APPROX. WT. LBS.
14"	14.00	1/4" x 5"	FC4-1400-A05R-TEC	150	9	81
	14.00	1/4" x 7"	FC4-1400-A07R-TEC	150	9	86
	14.00	3/8" x 7"	FC4-1400-B07R-BEC	150	9	84
	15.30	1/4" x 7"	FC4-1530-A07R-TEC	150	9	95
	15.30	3/8" x 7"	FC4-1530-B07R-BEC	150	9	93
16"	15.65	3/8" x 7"	FC4-1565-B07R-TEC	150	9	104
	16.00	1/4" x 5"	FC4-1600-A05R-TEC	150	10	108
	16.00	1/4" x 7"	FC4-1600-A07R-TEC	150	10	114
	16.00	3/8" x 7"	FC4-1600-B07R-BEC	150	10	112
	17.40	1/4" x 7"	FC4-1740-A07R-TEC	150	10	127
	17.40	3/8" x 7"	FC4-1740-B07R-BEC	150	10	125
18"	17.80	3/8" x 7"	FC4-1780-B07R-TEC	150	10	130
	18.00	1/4" x 5"	FC4-1800-A05R-TEC	150	11	127
	18.00	1/4" x 7"	FC4-1800-A07R-TEC	150	11	134
	18.00	3/8" x 7"	FC4-1800-B07R-BEC	150	11	132
	19.50	1/4" x 7"	FC4-1950-A07R-TEC	150	11	157
20"	19.50	3/8" x 7"	FC4-1950-B07R-BEC	150	11	155
	19.92	3/8" x 7"	FC4-1992-B07R-TEC	150	11	173
	20.00	1/4" x 7"	FC4-2000-A07R-TEC	150	12	173
	20.00	3/8" x 7"	FC4-2000-B07R-BEC	150	12	171
	21.60	1/4" x 7"	FC4-2160-A07R-TEC	150	12	192
24"	21.60	3/8" x 7"	FC4-2160-B07R-BEC	150	12	190
	22.06	3/8" x 7"	FC4-2206-B07R-TEC	150	12	197
	24.00	1/4" x 7"	FC4-2400-A07R-TEC	150	14	252
	24.00	3/8" x 7"	FC4-2400-B07R-BEC	150	14	250
	25.80	1/4" x 7"	FC4-2580-A07R-TEC	150	14	280
	25.80	3/8" x 7"	FC4-2580-B07R-BEC	150	14	278
	26.32	3/8" x 7"	FC4-2632-B07R-TEC	150	14	296

**Note:** End caps are optional with any FC4 coupling shown on pages 15 or 16. To order, add "-TEC" (tapped end cap code) or "-BEC" (blind end cap code) to the FC4 part number.

# Ford Steel Transition Couplings

## Style FC5

The Ford FC5 Transition Coupling is an all steel product designed to connect plain end pipes with different OD's. When ordering, use the table shown on the next page or use the exact O.D. measurements of the two pipes to be joined. The numbering system chart below shows how to order an FC5 coupling for your specific needs. Generally, the maximum differential between two pipes to be joined may not exceed 1" except as listed. For pipes with a measured differential of more than 1", refer to Ford FC6 Steel Reducing Couplings on page 20.

**Bolts and Nuts** - High strength low alloy steel per ASTM A242 and AWWA C111  
 Optional: - Type 304 stainless steel  
 - Type 316 stainless steel  
 - Electro-galvanized steel  
 - Blue Fluorocarbon coating

**Gaskets** - SBR extruded or molded rubber  
 Optional: - Buna-N  
 - EPDM

**Center Sleeve** - ASTM A36 carbon steel

**Finish** - Black shop coat  
 Optional: - Epoxy coating

**End Rings** - AISI 1018-1020 cold rolled or extruded carbon steel

**Caution: Flexible couplings do not restrain axial pipe movement. Unbalanced forces created by internal water pressure or external forces must be properly restrained.**

### How to order FC5 Couplings:

Our code system is used to designate the part number. Each code determines how the coupling will be manufactured. The example shown below is an FC5-2580-2632-B15R. This steel coupling is made to couple a 25.80 O.D. pipe to a 26.32 O.D. pipe using 3/8" by 15" long steel center sleeve, SBR gaskets, standard nuts and bolts and would be painted with our standard shop coat.

## FC5-2580-2632-B 15 R

Product Identification:  
Fabricated Steel Transition Coupling

Small End Pipe O.D.

Large End Pipe O.D.

Center Sleeve Thickness  
A = 1/4" Steel  
B = 3/8" Steel

Coupling Length  
10 = 10"  
12 = 12"  
15 = 15"  
20 = 20"  
24 = 24"

COATING, HARDWARE AND GASKET OPTIONS				
GASKET MATERIAL	COATING AND HDWR. COMBINATIONS			
	Standard Alloy Hdwr.	304 Stainless Steel Hdwr.	316 Stainless Steel Hdwr.	Electro Galvanized Hdwr.
<b>Standard Shop Coat</b>				
SBR Rubber	R	X	Q	G
Buna-N Rubber	N	H	J	F
EPDM Rubber	S	M	V	W
<b>Epoxy Coated</b>				
SBR Rubber	E	Y	Z	K
Buna-N Rubber	C	P	T	O
EPDM Rubber	A	B	D	L

Note: See item listings in catalog section to assure that desired sizes and options are available

# Ford Steel Transition Couplings

Style FC5

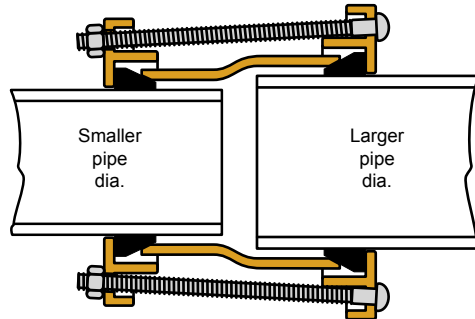

**DESIGN CONFIGURATION FOR FC5  
TRANSITION COUPLING**

**Listed below are the common sizes of FC5 couplings.**

If your pipe O.D. is not in the listed ranges, use the code number system on the previous page to create your catalog number. Remember that the diameters of the two pipes to be joined may not vary more than 1" except as listed. For larger variations, please refer to FC6 coupling information on page 20. Smaller sizes are shown as style FC23 on pages 8 through 11.

NOMINAL PIPE SIZE	1ST END GASKET RANGE	2ND END GASKET RANGE	CENTER SLEEVE INFORMATION	CATALOG NUMBER	NUMBER OF BOLTS	RATED WORKING PRESSURE	APPROX. WT. LBS.
14"	14.00	15.30	1/4" X 10"	FC5-1400-1530-A10R	9	200	85
	15.30	15.65	1/4" x 10"	FC5-1530-1565-A10R	9	416	91
	15.30	15.98	1/4" x 10"	FC5-1530-1598-A10R	9	416	96
	15.30	16.22	1/4" x 10"	FC5-1530-1622-A10R	9	410	97
16"	16.00	17.40	1/4" X 10"	FC5-1600-1740-A10R	10	200	96
	17.40	17.80	1/4" x 10"	FC5-1740-1780-A10R	10	372	102
	17.40	17.94	1/4" x 10"	FC5-1740-1794-A10R	10	372	107
	17.40	18.16	1/4" x 10"	FC5-1740-1816-A10R	10	372	107
18"	18.00	19.50	1/4" X 10"	FC5-1800-1950-A10R	11	200	109
	19.50	19.92	1/4" x 10"	FC5-1950-1992-A10R	11	337	114
20"	20.00	21.60	1/4" X 10"	FC5-2000-2160-A10R	12	200	116
	21.60	22.06	1/4" x 10"	FC5-2160-2206-A10R	12	313	124
	21.60	22.50	1/4" x 10"	FC5-2160-2250-A10R	12	313	124
24"	24.00	25.80	1/4" X 10"	FC5-2400-2580-A10R	14	200	137
	25.80	26.32	1/4" x 10"	FC5-2580-2632-A10R	14	250	146
	25.80	26.48	1/4" x 10"	FC5-2580-2648-A10R	14	250	146
30"	30.00	32.00	1/4" X 10"	FC5-3000-3200-A10R	16	200	157
	31.74	32.00	1/4" x 10"	FC5-3174-3200-A10R	16	230	165
	32.00	32.40	1/4" x 10"	FC5-3200-3240-A10R	16	230	166
	32.00	32.40	3/8" x 10"	FC5-3200-3240-B10R	16	230	184
	32.00	32.74	1/4" x 10"	FC5-3200-3274-A10R	16	230	166
36"	36.00	38.30	1/4" X 10"	FC5-3600-3830-A10R	18	193	186
	37.96	38.30	1/4" x 10"	FC5-3796-3830-A10R	18	193	225
	38.30	38.70	1/4" x 10"	FC5-3830-3870-A10R	18	193	230
	38.30	38.70	3/8" x 10"	FC5-3830-3870-B10R	18	193	267
	38.30	38.70	3/8" x 15"	FC5-3830-3870-B15R	18	193	341
	38.30	39.16	1/4" x 10"	FC5-3830-3916-A10R	18	193	230
42"	44.20	44.50	3/8" x 10"	FC5-4420-4450-B10R	20	250	318
	44.50	45.10	3/8" x 10"	FC5-4450-4510-B10R	20	250	320
	44.50	45.10	3/8" x 15"	FC5-4450-4510-B15R	20	250	415
	44.50	45.58	3/8" x 10"	FC5-4450-4558-B10R	20	250	320
48"	50.50	50.80	3/8" x 10"	FC5-5050-5080-B10R	22	220	363
	50.80	51.40	3/8" x 10"	FC5-5080-5140-B10R	22	220	363
	50.80	51.40	3/8" x 15"	FC5-5080-5140-B15R	22	220	465
	50.80	51.98	3/8" x 10"	FC5-5080-5198-B10R	22	220	363

# Ford Steel Reducing Couplings

## Style FC6

Ford Steel Reducing Couplings are designed to connect plain end pipes with an O.D. differential of more than 1". When ordering, use the table shown on the next page or use the exact O.D. measurements of the two plain end pipes to be joined.

**Bolts and Nuts** - High strength low alloy steel per ASTM A242 and AWWA C111  
 Optional: - Type 304 stainless steel  
 - Type 316 stainless steel  
 - Electro-galvanized steel  
 - Blue Fluorocarbon coating

**Body Sleeve** - ASTM A36 carbon steel

**Finish** - Black shop coat  
 Optional: - Epoxy coating

**Gasket** - SBR Rubber  
 Optional: - Buna-N  
 - EPDM

**End Rings** - 4" - 12" per ASTM A536 ductile iron; 14" - 60" AISI carbon steel (1018-1020) or ASTM A536 ductile iron

**Rated Working Water Pressure** - 150 psi working water pressure for a coupling with a reduction of 2 nominal pipe sizes or less.  
 For information about high pressure applications or reductions of more than two nominal pipe sizes, please contact your Ford Meter Box Customer Service Representative.

**Caution: Reducing couplings do not restrain axial pipe movement. Unbalanced forces created by internal water pressure or external forces must be properly restrained.**

### How to order FC6 couplings:

Our code system is used to designate the part number. Each code determines how the coupling will be manufactured. Select the large end catalog number and small catalog number from the chart on page 21. Ford will manufacture FC6 couplings to your specifications using the material and dimensional parameters listed below. **Before ordering a special pipe O.D., make sure your O.D. is not in the listed ranges.**

The example shown below is an FC6-1780-1275-R. This coupling is made to fit a 17.80 O.D. pipe and 12.75 O.D. pipe using standard bolts and finished with a standard shop coat.

## FC6-1780-1275-R

Product Identification:  
 Fabricated Steel Reducing Coupling

Large End Pipe O.D.

Small End Pipe O.D.

COATING, HARDWARE AND GASKET OPTIONS				
COATING AND HDWR. COMBINATIONS				
GASKET MATERIAL	Standard Alloy Hdwr.	304 Stainless Steel Hdwr.	316 Stainless Steel Hdwr.	Electro Galvanized Hdwr.
<b>Standard Shop Coat</b>				
SBR Rubber	R	X	Q	G
Buna-N Rubber	N	H	J	F
EPDM Rubber	S	M	V	W
<b>Epoxy Coated</b>				
SBR Rubber	E	Y	Z	K
Buna-N Rubber	C	P	T	O
EPDM Rubber	A	B	D	L

Note: See item listings in catalog section to assure that desired sizes and options are available

# Ford Steel Reducing Couplings

Style FC6

Large End					BY	Small End				
NOM. PIPE SIZE	LARGE END RANGE	LARGE END CATALOG NUMBER	LENGTH OF LRG. END	NUMBER OF BOLTS		NOM. PIPE SIZE	SMALL END RANGE	SMALL END CATALOG NUMBER	LENGTH OF SM. END	NUMBER OF BOLTS
4"	4.00	FC6-400	5"	3		2"	2.30-2.45	-245-R	7"	2
	4.50-4.80	FC6-480	5"	3			2.40-2.65	-265-R	7"	2
	4.80-5.10	FC6-510	5"	3			2.65-2.88	-288-R	7"	2
	5.15-5.57	FC6-557	5"	3		3"	3.45-3.60	-360-R	7"	3
6.00	FC6-600	5"	4	3.70-3.88			-388-R	7"	3	
6.63-6.90	FC6-690	5"	4	4.07-4.20			-420-R	7"	3	
6"	6.90-7.20	FC6-720	5"	4		4"	4.00	-400-R	7"	3
	7.21-7.56	FC6-756	5"	4			4.50-4.80	-480-R	7"	3
	8.00	FC6-800	5"	5			4.80-5.10	-510-R	7"	3
	8.63-9.05	FC6-905	5"	5			5.15-5.57	-557-R	7"	3
8"	9.05-9.40	FC6-940	5"	5		6"	6.00	-600-R	7"	4
	9.40-9.74	FC6-974	5"	5			6.63-6.90	-690-R	7"	4
	10.00	FC6-1000	5"	6			6.90-7.20	-720-R	7"	4
	10.75	FC6-1075	5"	6			7.21-7.56	-756-R	7"	4
10"	11.10-11.46	FC6-1146	5"	6		8"	8.00	-800-R	7"	5
	11.42-11.77	FC6-1177	5"	6			8.63-9.05	-905-R	7"	5
	11.77-12.12	FC6-1212	5"	6			9.05-9.40	-940-R	7"	5
	12.00	FC6-1200	5"	7			9.40-9.74	-974-R	7"	5
12"	12.75	FC6-1275	5"	7		10"	10.00	-1000-R	7"	6
	13.20-13.56	FC6-1356	5"	7			10.75	-1075-R	7"	6
	13.69-14.04	FC6-1404	5"	7			11.10-11.46	-1146-R	7"	6
	14.04-14.38	FC6-1438	5"	7			11.42-11.77	-1177-R	7"	6
14"-16"	15.30-15.70	FC6-1570	5"	9		12"	11.77-12.12	-1212-R	7"	6
	16.00-16.35	FC6-1635	5"	9			12.00	-1200-R	7"	7
	16.40-16.88	FC6-1688	5"	9			12.75	-1275-R	7"	7
	17.40-17.80	FC6-1780	5"	10			13.20-13.56	-1356-R	7"	7
16"-18"	18.25	FC6-1825	5"	11		14"-16"	13.69-14.04	-1404-R	7"	7
	18.90-19.20	FC6-1920	5"	10			14.04-14.38	-1438-R	7"	7
	19.50-20.00	FC6-2000	5"	11			15.30-15.70	-1570-R	7"	9
	21.60-22.06	FC6-2206	5"	12			16.00-16.35	-1635-R	7"	9
24"	24.00	FC6-2400	5"	14		16"-18"	16.40-16.88	-1688-R	7"	9
	25.80	FC6-2580	5"	14			17.40-17.80	-1780-R	7"	10
	26.32	FC6-2632	5"	14			18.25	-1825-R	7"	11
	30.00	FC6-3000	5"	16			18.90-19.20	-1920-R	7"	10
30"	32.00	FC6-3200	5"	16		18"-20"	19.50-20.00	-2000-R	7"	11
	32.40	FC6-3240	5"	16			21.60-22.06	-2206-R	7"	12
	36.00	FC6-3600	5"	18			24.00	-2400-R	7"	14
	38.30	FC6-3830	5"	18			25.80	-2580-R	7"	14
42"	42.00	FC6-4200	5"	20		24"	26.32	-2632-R	7"	14
	44.50	FC6-4450	5"	20			30.00	-3000-R	7"	16
	48.00	FC6-4800	5"	22			32.00	-3200-R	7"	16
	49.00	FC6-4900	5"	22			32.40	-3240-R	7"	16
48"	50.80	FC6-5080	5"	22		36"	36.00	-3600-R	7"	18
	55.00	FC6-5500	5"	24			38.30	-3830-R	7"	18
	56.66	FC6-5666	5"	24			42.00	-4200-R	7"	20
	57.10	FC6-5710	5"	24			44.50	-4450-R	7"	20
54"	57.56	FC6-5756	5"	24		42"	48.00	-4800-R	7"	22
	57.80	FC6-5780	5"	24			49.00	-4900-R	7"	22
	60.00	FC6-6000	5"	26	50.80		-5080-R	7"	22	
	61.00	FC6-6100	5"	26	55.00		-5500-R	7"	24	
60"	61.61	FC6-6161	5"	26	54"	56.66	-5666-R	7"	24	
	63.40	FC6-6340	5"	26		57.10	-5710-R	7"	24	
						57.56	-5756-R	7"	24	
						57.80	-5780-R	7"	24	
60"					60"	60.00	-6000-R	7"	26	
						61.00	-6100-R	7"	26	
						61.61	-6161-R	7"	26	
						63.40	-6340-R	7"	26	

# Ford Steel Flange Coupling Adapters

## Style FCA

Ford Steel Flange Coupling Adapters are used to connect plain end pipe to flanged fittings such as meters or valves. Thrust protection must be provided to prevent the pipe from blowing out of the adapter. Optional restrainers or anchor studs are offered as thrust protection. Fabricated steel flange coupling adapters are normally furnished with flange size matching the nominal pipe size; however, reduced flange sizes are available. For example, a 16" FCA may be ordered with a 12" flange.

**Bolts and Nuts** - High strength low alloy steel per ASTM A242 and AWWA C111  
 Optional: - Type 304 stainless steel  
 - Type 316 stainless steel  
 - Electro-galvanized steel  
 - Blue Fluorocarbon coating

**Body Sleeve** - ASTM A36 carbon steel

**Anchor Studs (Optional)** - Cold rolled steel per AISI 1141

**Flange** - AWWA C207 class D flange.  
 Optional: Other AWWA, ISO, DIN or custom flanges are available

**Finish** - Black shop coat  
 Optional: - Epoxy coating

**Gasket** - SBR rubber  
 Optional: - Buna-N  
 - EPDM

**End Ring** - 4" - 12" per ASTM A536 Ductile iron; 16" - 60" AISI 1018-1020 carbon steel or ASTM A536 ductile iron



**Caution: Flexible couplings do not restrain axial pipe movement. Unbalanced forces created by internal water pressure or external forces must be restrained. Restrained couplings using Uni-Flange restrainers can be found in Catalog Section U. Contact factory for details.**

### How to order FCA couplings:

Orders may be placed by using catalog numbers from pages 24 and 25, which designate the pipe O.D. and flange size. If the pipe size or desired options are not listed, use the code system detailed below to create the catalog number. Each field of the number is significant in determining exactly how the coupling will be manufactured. The example shown below is an FCA-1780-D12R-AS4. This steel reducing flanged coupling adapter is made to fit a range of pipe sizes from 17.40" to 17.80" and has a 12" AWWA Class D flange. The four anchor studs on this unit will prevent pipe movement up to a maximum operating pressure of 100 psi.

## FCA-1780-D12R-AS4

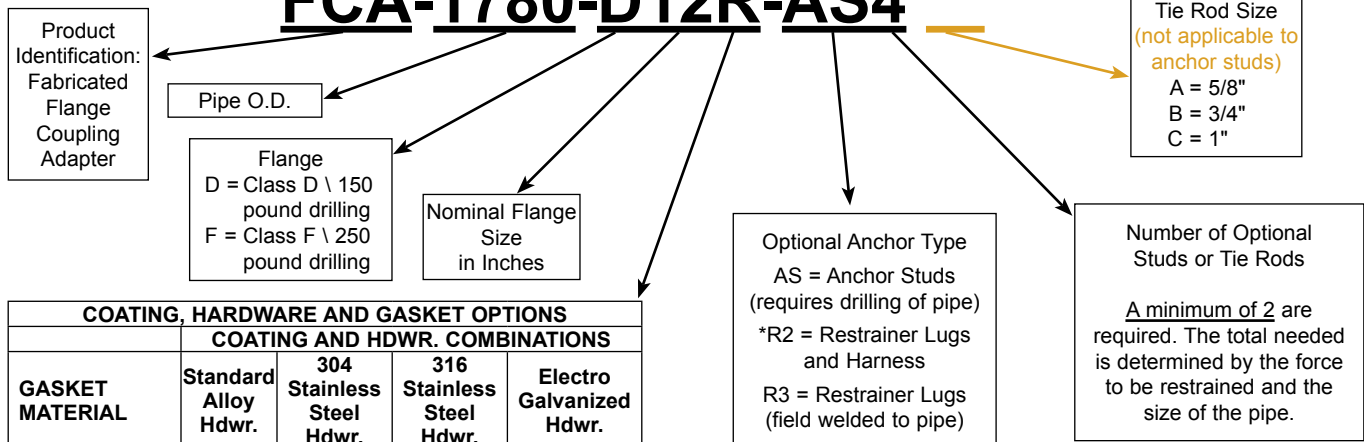

COATING, HARDWARE AND GASKET OPTIONS				
COATING AND HDWR. COMBINATIONS				
GASKET MATERIAL	Standard Alloy Hdwr.	304 Stainless Steel Hdwr.	316 Stainless Steel Hdwr.	Electro Galvanized Hdwr.
<b>Standard Shop Coat</b>				
SBR Rubber	R	X	Q	G
Buna-N Rubber	N	H	J	F
EPDM Rubber	S	M	V	W
<b>Epoxy Coated</b>				
SBR Rubber	E	Y	Z	K
Buna-N Rubber	C	P	T	O
EPDM Rubber	A	B	D	L

Note: See item listings in catalog section to assure that desired sizes and options are available

Please contact the Ford Customer Service Department for information about anchor studs or other restraint requirements for your specific application.

\* Restrainer harness assemblies are manufactured to a specific pipe O.D. **Please include the specific pipe O.D. on order.** See Ford Restrainer Assemblies (page 30) for more information.

# Ford Steel Flange Coupling Adapters

Style FCA

Example of Part Number System

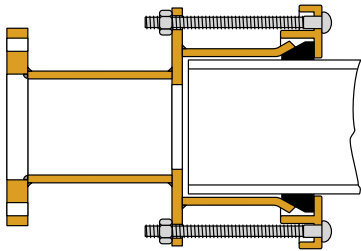

**FCA-1146-D8R**  
Reducing FCA Coupling

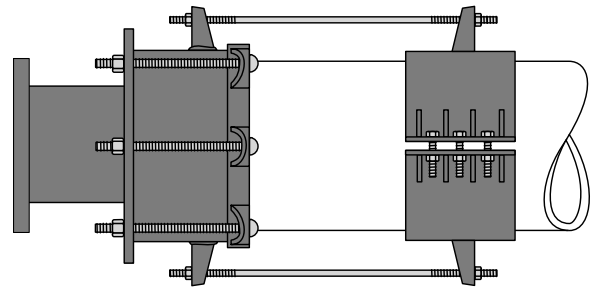

**FCA-1110-D8R-R22A**  
Reducing FCA Coupling with optional  
restrainer lug and harness assembly  
Note: Exact pipe O.D. is required to ensure  
proper harness size.

## Dimension Chart

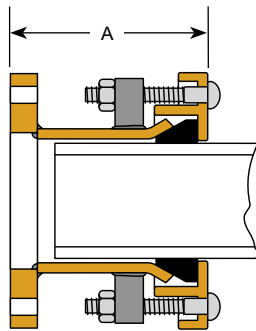

**Standard FCA Coupling**

Pipe Size	"A" Dimension
4" - 6"	8.5"
8" - 48"	11.5"

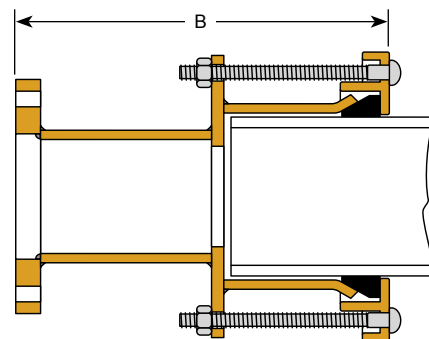

**Reducing FCA Coupling**

Pipe Size	"B" Dimension
4" - 12"	13.5"
14" - 30"	14.75"
36" - 48"	15"

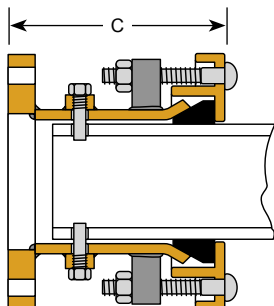

**FCA Coupling with (AS)  
Optional anchor studs  
(for ductile iron or steel pipe,  
anchor studs require drilling of pipe)**

Pipe Size	"C" Dimension
4" - 6"	11.5"
8" - 48"	13.5"

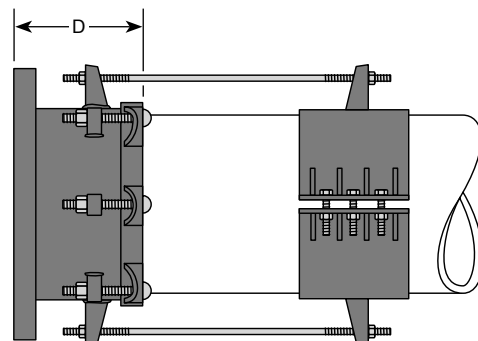

**FCA Coupling with (R2) Optional  
Restrainer Lug and Harness Assembly**

Pipe Size	"D" Dimension
4" - 6"	13.5"
8" - 48"	15.5"

# Ford Steel Flange Coupling Adapters

## Style FCA

*Listed below are the common sizes of FCA couplings.*

If your pipe O.D. is not in the listed ranges, use the code system to create your catalog number. (See page 22). Ductile iron flange coupling adapters are detailed in catalog section M.

NOM. PIPE SIZE	PIPE O.D.	FLANGE SIZE	RANGE (COUPLING END)	CATALOG NUMBER	RATED WORKING PRESSURE	NUMBER OF END RING BOLTS	APPROX. WT. LBS.
4"	4.00	4"	4.00	FCA-400-D4R	175	3	26
	4.50	4"	4.50-4.80	FCA-480-D4R	175	3	26
	4.80	4"	4.50-4.80	FCA-480-D4R	175	3	26
6"	6.00	4"	6.00	FCA-600-D4R	175	4	40
	6.00	6"	6.00	FCA-600-D6R	175	4	36
	6.63	4"	6.63-6.90	FCA-690-D4R	175	4	40
	6.63	6"	6.63-6.90	FCA-690-D6R	175	4	36
	6.90	4"	6.63-6.90	FCA-690-D4R	175	4	40
	6.90	6"	6.63-6.90	FCA-690-D6R	175	4	36
	8.63	4"	8.63-9.05	FCA-905-D4R	175	5	46
8"	8.00	6"	8.00	FCA-800-D6R	175	5	48
	8.00	8"	8.00	FCA-800-D8R	175	5	49
	8.63	6"	8.63-9.05	FCA-905-D6R	175	5	53
	8.63	8"	8.63-9.05	FCA-905-D8R	175	5	49
	9.05	4"	8.63-9.05	FCA-905-D4R	175	5	46
	9.05	6"	8.63-9.05	FCA-905-D6R	175	5	53
	9.05	8"	8.63-9.05	FCA-905-D8R	175	5	49
10"	10.00	8"	10.00	FCA-1000-D8R	175	6	60
	10.00	10"	10.00	FCA-1000-D10R	175	6	64
	10.75	6"	10.75	FCA-1075-D6R	175	6	66
	10.75	8"	10.75	FCA-1075-D8R	175	6	70
	10.75	10"	10.75	FCA-1075-D10R	175	6	63
	11.10	6"	11.10-11.46	FCA-1146-D6R	175	6	62
	11.10	8"	11.10-11.46	FCA-1146-D8R	175	6	71
12"	11.10	10"	11.10-11.46	FCA-1146-D10R	175	6	62
	12.00	10"	12.00	FCA-1200-D10R	175	7	78
	12.00	12"	12.00	FCA-1200-D12R	175	7	81
	12.75	8"	12.75	FCA-1275-D8R	175	7	82
	12.75	10"	12.75	FCA-1275-D10R	175	7	92
	12.75	12"	12.75	FCA-1275-D12R	175	7	89
	13.20	8"	13.20-13.56	FCA-1356-D8R	175	7	80
14"	13.20	10"	13.20-13.56	FCA-1356-D10R	175	7	91
	13.20	12"	13.20-13.56	FCA-1356-D12R	175	7	87
	14.00	10"	13.69-14.04	FCA-1404-D10R	175	9	92
	14.00	12"	13.69-14.04	FCA-1404-D12R	175	9	114
	15.30	10"	15.30-15.70	FCA-1570-D10R	175	9	131
	15.30	12"	15.30-15.70	FCA-1570-D12R	175	9	151
	15.30	14"	15.30	FCA-1530-D14R	150	9	121
16"	16.00	12"	16.00-16.35	FCA-1635-D12R	175	10	152
	16.00	14"	16.00-16.35	FCA-1635-D14R	150	10	166
	16.00	16"	16.00	FCA-1600-D16R	150	10	138
	17.40	12"	17.40-17.80	FCA-1780-D12R	175	10	176
	17.40	14"	17.40-17.80	FCA-1780-D14R	150	10	170
	17.40	16"	17.40	FCA-1740-D16R	150	10	144
	17.80	16"	17.80	FCA-1780-D16R	150	10	145



# Ford Steel Flange Coupling Adapters

Style FCA

*Listed below are the common sizes of FCA couplings.*

If your pipe O.D. is not in the listed ranges, use the code system to create your catalog number. (See page 22). Ductile iron flange coupling adapters are detailed in catalog section M.

NOM. PIPE SIZE	PIPE O.D.	FLANGE SIZE	RANGE (COUPLING END)	CATALOG NUMBER	RATED WORKING PRESSURE	NUMBER OF END RING BOLTS	APPROX. WT. LBS.
18"	18.00	14"	18.00	FCA-1800-D14R	150	11	195
	18.00	16"	18.00	FCA-1800-D16R	150	11	203
	18.00	18"	18.00	FCA-1800-D18R	150	11	151
	19.50	14"	19.50-20.00	FCA-2000-D14R	150	11	194
	19.50	16"	19.50-20.00	FCA-2000-D16R	150	11	210
20"	19.50	18"	19.50	FCA-1950-D18R	150	11	154
	20.00	16"	19.50-20.00	FCA-2000-D16R	150	11	210
	20.00	18"	19.50-20.00	FCA-2000-D18R	150	11	194
	20.00	20"	20.00	FCA-2000-D20R	150	12	175
	21.60	16"	21.60-22.06	FCA-2206-D16R	150	12	202
	21.60	18"	21.60-22.06	FCA-2206-D18R	150	12	195
	21.60	20"	21.60	FCA-2160-D20R	150	12	180
24"	22.06	24"	22.06	FCA-2206-D20R	150	12	180
	24.00	18"	24.00	FCA-2400-D18R	150	14	369
	24.00	20"	24.00	FCA-2400-D20R	150	14	300
	24.00	24"	24.00	FCA-2400-D24R	150	14	226
	25.80	18"	25.80	FCA-2580-D18R	150	14	278
	25.80	20"	25.80	FCA-2580-D20R	150	14	250
30"	25.80	24"	25.80	FCA-2580-D24R	150	14	233
	30.00	20"	30.00	FCA-3000-D20R	150	16	320
	30.00	24"	30.00	FCA-3000-D24R	150	16	376
	30.00	30"	30.00	FCA-3000-D30R	150	16	314
	32.00	20"	32.00	FCA-3200-D20R	150	16	323
36"	32.00	24"	32.00	FCA-3200-D24R	150	16	323
	32.00	30"	32.00	FCA-3200-D30R	150	16	323
	36.00	24"	36.00	FCA-3600-D24R	150	18	400
	36.00	30"	36.00	FCA-3600-D30R	150	18	435
	36.00	36"	36.00	FCA-3600-D36R	150	18	472
	38.30	24"	38.30	FCA-3830-D24R	150	18	439
42"	38.30	30"	38.30	FCA-3830-D30R	150	18	420
	38.30	36"	38.30	FCA-3830-D36R	150	18	411
	42.00	30"	42.00	FCA-4200-D30R	150	20	550
	42.00	36"	42.00	FCA-4200-D36R	150	20	600
	42.00	42"	42.00	FCA-4200-D42R	150	20	628
	44.50	30"	44.50	FCA-4450-D30R	150	20	600
	44.50	36"	44.50	FCA-4450-D36R	150	20	630
48"	44.50	42"	44.50	FCA-4450-D42R	150	20	658
	48.00	36"	48.00	FCA-4800-D36R	150	24	700
	48.00	42"	48.00	FCA-4800-D42R	150	24	750
	48.00	48"	48.00	FCA-4800-D48R	150	24	768
	50.80	36"	50.80	FCA-5080-D36R	150	24	700
	50.80	42"	50.80	FCA-5080-D42R	150	24	750
	50.80	48"	50.80	FCA-5080-D48R	150	24	766

# Ford Dismantling Joint

## Style FDJ

Ford Dismantling Joints are flanged joint fittings that provide longitudinal adjustment in a flanged piping system. This allows for flexibility during design and installation as well as easy accessibility for maintenance.

**Bolts and Nuts** - High strength, low alloy steel per AWWA C111  
**Optional:** - Blue Fluorocarbon coating

**Tie Rods** are optional. High strength, low alloy steel per AWWA C111.  
**Optional:** Blue Fluorocarbon coating

**Body and Adjusting Pipe** - ASTM A36 carbon steel

**Flanges** - ASTM A36 carbon steel, AWWA C207 Class D  
 Other flanges available upon request

**Style A**  
 4" - 12" furnished with cross bolts and tee-bolts (shown less tie rods)

**Body and End Ring (Style A)** - Ductile iron per ASTM A536 65-45-12

**Style B**

**Finish** - Black shop coat  
**Optional:** - Epoxy coating

**End Ring** - Cold rolled or extruded carbon steel per ANSI 1018-1020

**Gaskets** - SBR extruded or molded rubber per ASTM D2000

**150 psi rated working water pressure. Higher pressure ratings available. Please contact factory. Unbalanced forces created by internal water pressure or external forces must be restrained.**

### Dismantling Joints Less Tie Rods

NOMINAL SIZE	CATALOG NUMBER	STYLE	NOMINAL LENGTH	MINIMUM LENGTH	MAXIMUM LENGTH	APPROX. WEIGHT LBS.
2"	FDJ-D2R	B	See Submittals Online For Dimensions			27
3"	FDJ-D3R	A				31
4"	FDJ-D4R	A				36
6"	FDJ-D6R	A				52
8"	FDJ-D8R	A				75
10"	FDJ-D10R	A				90
12"	FDJ-D12R	A				127
14"	FDJ-D14R	B				280
16"	FDJ-D16R	B				295
18"	FDJ-D18R	B				305
20"	FDJ-D20R	B				315
24"	FDJ-D24R	B				645
30"	FDJ-D30R	B				945
36"	FDJ-D36R	B				963

### Dismantling Joints with Tie Rods

NOMINAL SIZE	CATALOG NUMBER	STYLE	NOMINAL LENGTH	MINIMUM LENGTH	MAXIMUM LENGTH	TIE RODS		APPROX. WEIGHT LBS.
						NUMBER	SIZE	
4"	FDJ-D4R-R	A	See Submittals Online For Dimensions					38
6"	FDJ-D6R-R	A						55
8"	FDJ-D8R-R	A						78
10"	FDJ-D10R-R	A						93
12"	FDJ-D12R-R	A						130
14"	FDJ-D14R-R	B						285
16"	FDJ-D16R-R	B						300
18"	FDJ-D18R-R	B						310
20"	FDJ-D20R-R	B						320
24"	FDJ-D24R-R	B						650
30"	FDJ-D30R-R	B						955
36"	FDJ-D36R-R	B						975

# Ford Steel Expansion Joints

Style FEJ

Ford Expansion Joint Couplings (FEJ) are specified for piping projects to allow for thermal expansion and contraction. The amount of movement is a factor of the pipe material, the pipeline length, the temperature differential and structural movement. The chart on page 29 shows linear pipe expansion of commonly used water pipe materials.

The Single Expansion Joint Coupling (FEJ1) features **10" of overall pipe movement** with limit rods that transfer pipe movement to any additional expansion joints. The slip pipe provides a non-abrasive surface to prevent damage to the packing glands. The friction of the packing glands on the slip pipe may be field adjusted using the packing adjusting nuts. Pipe movement may be controlled in both directions unless the Expansion Joint is anchored to a supporting structure. The expansion joint is available with either flanged ends or plain ends, beveled for field welding.

## Single Expansion Joint - FEJ1 (with flanged ends)

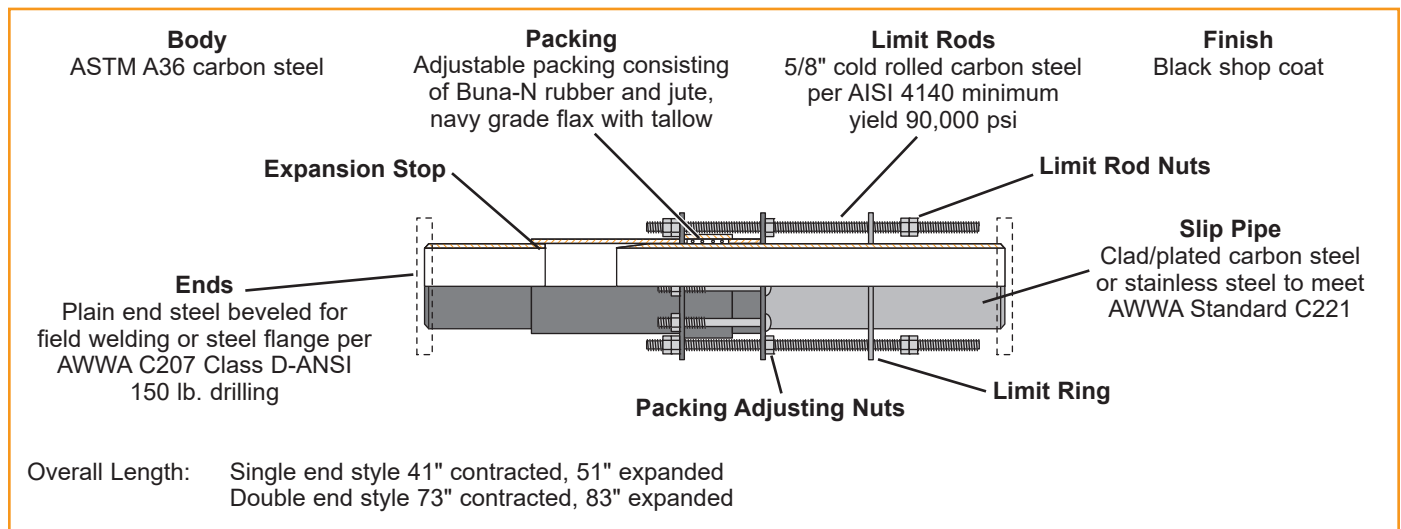
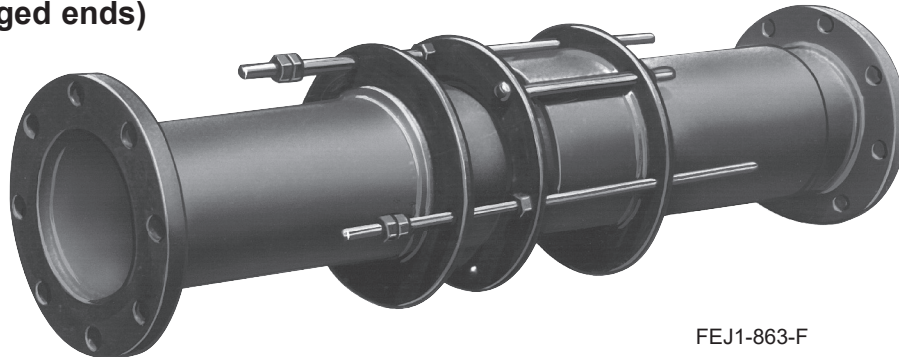

The Double Expansion Joint Coupling (FEJ2) also features two slip pipes and adjustable packing glands. The Double Style Expansion Coupling should be permanently attached to a supporting structure in the middle of the sleeve to force equal pipe movement of 5" in both directions. The expansion joint is available with either flanged ends or plain ends, beveled for field welding.

## Double Expansion - FEJ2 (with plain ends)

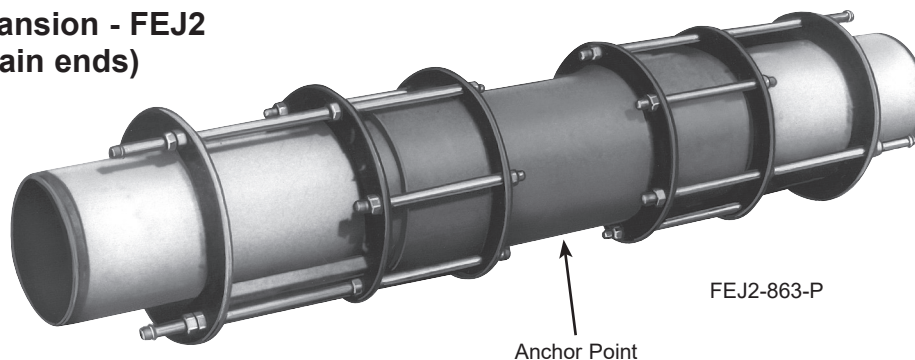

# Ford Steel Expansion Joints

## Style FEJ

Listed below are common sizes of FEJ couplings.

NOM. PIPE SIZE	PIPE O.D.	NO. OF PACKING CHAMBERS	TYPE OF END CONNECTION	CATALOG NUMBER	RATED WORKING PRESSURE	APPROX. WT. LBS.
4"	4.50	1	Plain	FEJ1-450-P	150	97
		2	Plain	FEJ2-450-P	150	148
		1	Flanged	FEJ1-450-F	150	114
		2	Flanged	FEJ2-450-F	150	165
6"	6.63	1	Plain	FEJ1-663-P	150	139
		2	Plain	FEJ2-663-P	150	310
		1	Flanged	FEJ1-663-F	150	160
		2	Flanged	FEJ2-663-F	150	331
8"	8.63	1	Plain	FEJ1-863-P	150	214
		2	Plain	FEJ2-863-P	150	340
		1	Flanged	FEJ1-863-F	150	244
		2	Flanged	FEJ2-863-F	150	370
10"	10.75	1	Plain	FEJ1-1075-P	150	244
		2	Plain	FEJ2-1075-P	150	447
		1	Flanged	FEJ1-1075-F	150	283
		2	Flanged	FEJ2-1075-F	150	487
12"	12.75	1	Plain	FEJ1-1275-P	150	299
		2	Plain	FEJ2-1275-P	150	551
		1	Flanged	FEJ1-1275-F	150	366
		2	Flanged	FEJ2-1275-F	150	618
14"	14.00	1	Plain	FEJ1-1400-P	150	338
		2	Plain	FEJ2-1400-P	150	514
		1	Flanged	FEJ1-1400-F	150	426
		2	Flanged	FEJ2-1400-F	150	602
16"	16.00	1	Plain	FEJ1-1600-P	150	389
		2	Plain	FEJ2-1600-P	150	587
		1	Flanged	FEJ1-1600-F	150	513
		2	Flanged	FEJ2-1600-F	150	711
18"	18.00	1	Plain	FEJ1-1800-P	125	426
		2	Plain	FEJ2-1800-P	125	662
		1	Flanged	FEJ1-1800-F	125	552
		2	Flanged	FEJ2-1800-F	125	788
20"	20.00	1	Plain	FEJ1-2000-P	110	497
		2	Plain	FEJ2-2000-P	110	738
		1	Flanged	FEJ1-2000-F	110	655
		2	Flanged	FEJ2-2000-F	110	895
24"	24.00	1	Plain	FEJ1-2400-P	100	607
		2	Plain	FEJ2-2400-P	100	887
		1	Flanged	FEJ1-2400-F	100	843
		2	Flanged	FEJ2-2400-F	100	1103



# Ford Steel Expansion Joints

Style FEJ

Ford FEJ Expansion Joint Couplings are specified for piping projects to allow for thermal expansion and contraction of pipe. Actual pipe movement is a result of changes in the ambient temperature, changes to the line content, and/or movement of the pipe supporting structures. The amount of movement is a factor of the pipe material, the pipeline length, and the temperature differential. The number of expansion joints required on each project is determined by the total pipe expansion. Each expansion joint controls 10" of pipe movement. The following chart shows linear pipe expansion of commonly used water pipe materials. Structural movement can also effect pipe expansion and contraction.

## LINEAR EXPANSION OF PIPE\*

TEMPERATURE DIFFERENTIAL DEGREES FAHRENHEIT	INCREASE IN INCHES PER 100 FEET OF PIPE FROM 0 TO TEMPERATURE INDICATED							
	CONCRETE	CAST IRON	DUCTILE IRON	STEEL	WROUGHT IRON	BRASS & COPPER	PVC	HDPE
0	0.000	0.000	0.000	0.000	0.000	0.000	0.000	0.000
10	0.066	0.072	0.074	0.076	0.079	0.114	0.360	0.960
20	0.132	0.144	0.149	0.152	0.158	0.228	0.720	1.920
30	0.198	0.216	0.223	0.228	0.237	0.342	1.080	2.880
40	0.264	0.288	0.298	0.304	0.316	0.456	1.440	3.840
50	0.330	0.360	0.372	0.380	0.395	0.570	1.800	4.800
60	0.396	0.432	0.446	0.465	0.474	0.684	2.160	5.760
70	0.462	0.504	0.521	0.532	0.553	0.798	2.520	6.720
80	0.528	0.576	0.595	0.608	0.632	0.912	2.880	7.680
90	0.594	0.648	0.670	0.684	0.711	1.206	3.240	8.640
100	0.660	0.744	0.744	0.76	0.79	1.14	3.600	9.600
125	0.825	0.88	0.930	0.92	0.97	1.40	4.500	12.000
150	0.990	1.10	1.116	1.15	1.21	1.75	5.400	14.400
175	1.155	1.28	1.302	1.34	1.41	2.04	6.300	16.800

To calculate total pipe movement: 1. Determine the temperature range in your geographic area, 2. Cross reference with the appropriate pipe material from the above table. **Note:** This figure is based on 100 feet of pipe. Total pipe expansion must take into account the entire length of pipe.

\*This table is a general guide for pipe expansion/contraction length only. It is not intended to recommend or approve any pipe or appurtenance (either direct or indirect) for use at a listed temperature or temperature range. Internal pressure variations can also affect plastic pipe length changes.

## Installation Instructions for Ford Steel Expansion Joints

Ford Expansion Joints are shipped in the fully closed position and must be adjusted to meet field temperature conditions during installation. To adjust, follow these instructions:

### FOR FEJ1 SINGLE END STYLE EXPANSION JOINT ONLY

1. Calculate the initial installation setting by solving the formula below.

$$\frac{\text{MAXIMUM TEMPERATURE} - \text{INSTALLATION TEMPERATURE}}{\text{MAXIMUM TEMPERATURE} - \text{MINIMUM TEMPERATURE}} \times 10 = \text{INITIAL SETTING IN INCHES}$$

2. Move limit rod nuts to initial setting as calculated in step 1 by measuring from closed position. Expand joint to this position. Attach both expansion joint ends to main line pipe.
3. Make final adjustments by positioning limit rod nuts as follows:  
TOTAL JOINT RANGE EXPANSION (NORMALLY 10") - INITIAL SETTING = LIMIT ROD NUT DISTANCE FROM LIMIT RING
4. Make sure pipe is properly aligned to ensure ease of expansion.
5. Tighten packing adjusting nuts to 60 ft-lbs.
6. Apply water pressure and test for leaks. If leaks appear around slip pipe, tighten packing gland nuts evenly until leak stops.

# Ford Restrainer Assemblies

## Style FR

Ford Restrainers (FR Style) are designed to prevent pipe movement caused by expansion and contraction, pressure surges, water hammer, and unstable ground conditions. The FR1 Harness-style Restrainer Assembly is suitable for pipe that cannot be easily welded in the field. The clamping force provided by the harness is evenly distributed along the surface of the pipe to prevent damage. All harness assemblies are manufactured for an exact pipe O.D.

The harness to lug restrainer assembly, style FR2, requires field welding of the lugs to steel pipe. This is normally done after the harness assembly is installed, in order to ensure proper alignment for the tie rods. The FR3 lug-to-lug style restrainer assembly is used to restrain steel pipe to pipe or to fittings such as a flanged coupling adapter.

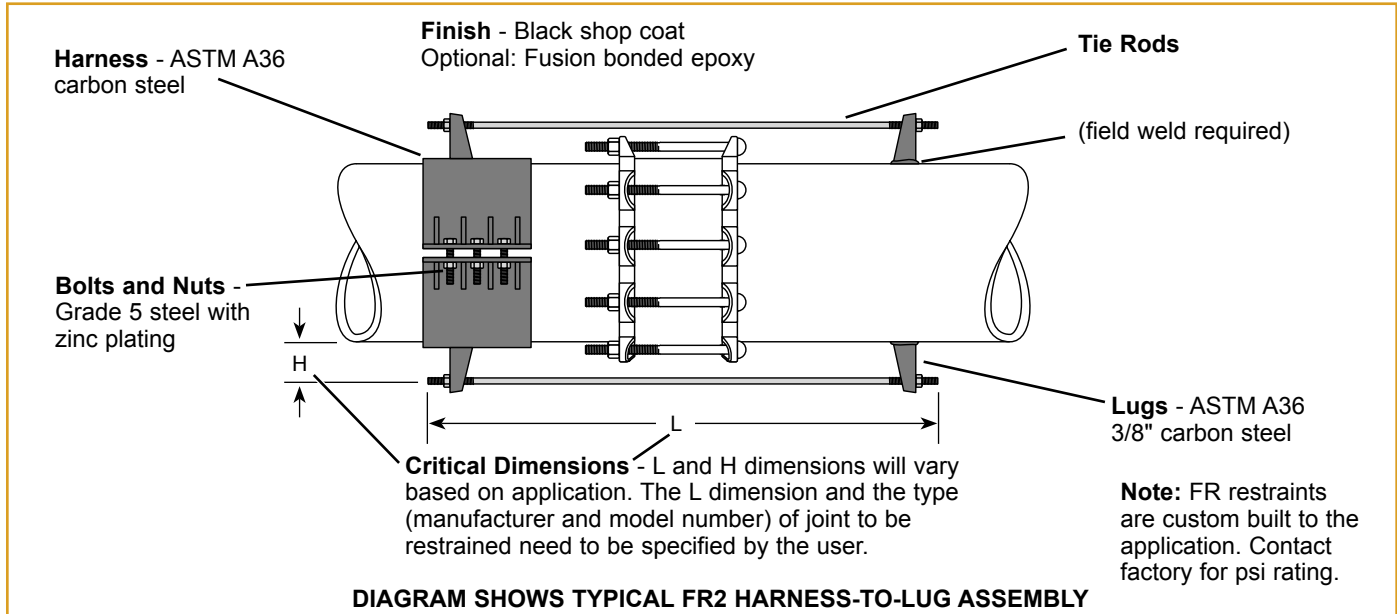

### How to order FR Restrainer

Select from page 31 the style assembly most suitable for your application. Note working pressure, pipe O.D., pipe type and all critical dimensions (see drawing above) required for installation. Dimension information is critical to ensure the tie rods will clear pipe joints or any other fitting involved.

Our code system is used to designate the part number. Each code determines how the assembly will be manufactured. Ford will manufacture FR Restrainer assemblies to your specifications. The example shown below is a FR1-663P-690D-2A. This is a harness assembly made to restrain a 6.63 O.D. plastic pipe to a 6.90 O.D. ductile iron pipe and uses two, 5/8" tie rods. All restrainer assemblies are individually quoted.

## FR1-663 P-690 D-2 A

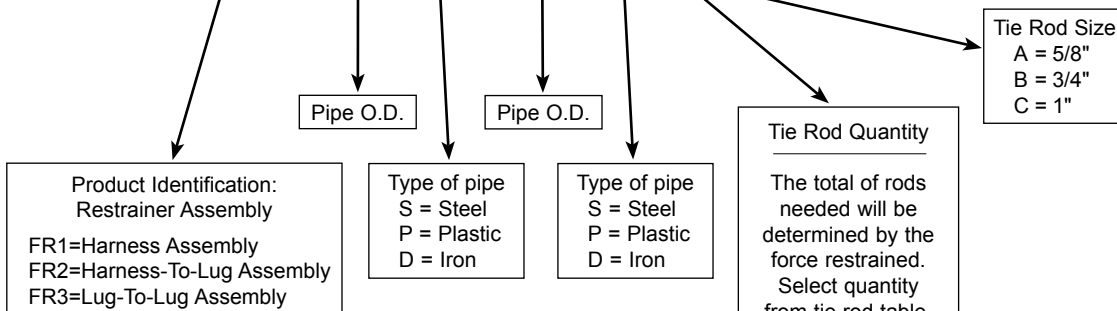

Tie Rod Table  
Size and Quantity  
for 150 PSI rated  
working pressure

NOM PIPE SIZE	QTY.	ROD SIZE
4	2	5/8"
6	2	5/8"
8	2	5/8"
10	2	3/4"
12	4	5/8"
14	4	3/4"
16	6	3/4"

**Be sure to check the Uni-Flange Catalog and Price Book for additional information and options for restraining PVC and ductile iron pipe joints. Contact Ford for technical support as well as for pricing and availability information regarding restrainer assemblies.**

# Ford Restrainer Assemblies

Style FR

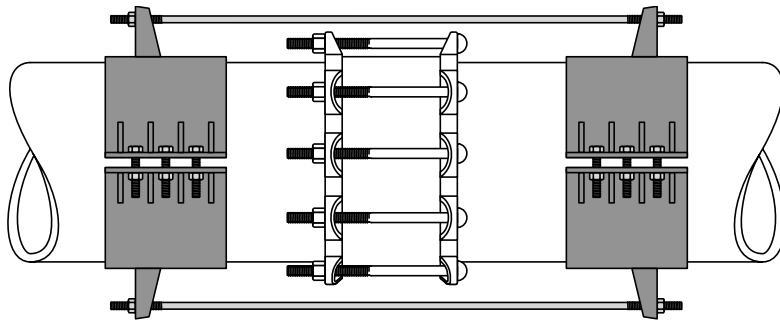

## FR1 - Harness Style Restrainer Assembly

Saddle to saddle assembly for use on steel, PVC, cast iron or ductile iron pipe.

*A complete assembly includes 2 harnesses and a minimum of 2 tie rods.*

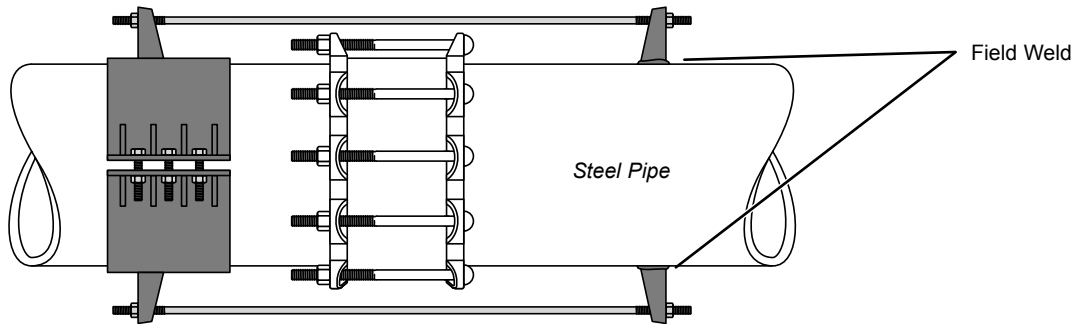

## FR2 - Harness-To-Lug Style Restrainer Assembly

Harness to lug assembly for use on steel pipe

*A complete assembly includes 1 harness, and a minimum of 2 lugs and 2 tie rods.*

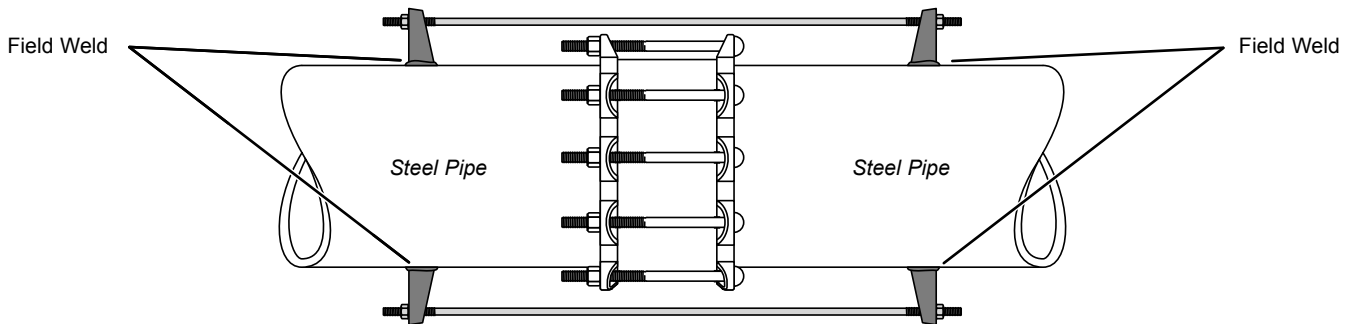

## FR3 - Lug-To-Lug Style Restrainer Assembly

Lug to lug assembly for use on steel pipe or steel fittings such as a steel flange coupling adapter.

*A complete assembly includes a minimum of 4 lugs and 2 tie rods.*

# Ford Steel Weld-On Tapping Sleeves

## Style FWS

The Ford Weld-on Tapping Sleeve is designed for field welding to steel pipe. The saddle, sized to fit the pipe, has rounded corners to allow a continuous weld. The welding surface is not painted. The standard steel flange conforms to AWWA C207 Class D ANSI 150 drilling and all sleeves are furnished with a 3/4" test port. Please note that sleeves with outlet sizes through 12" require the use of a shell cutter 1/2" smaller than the nominal flange size. Larger sizes require a shell cutter 1" smaller than the flange size.



### Style FWS Weld-On Tapping Sleeves

NOM PIPE SIZE	PIPE O.D.	FLANGE SIZE	CATALOG NUMBER	PRESSURE RATING
3"	3.50	3"	FWS-350-3	175
		3"	FWS-400-3	175
4"	4.00	4"	FWS-400-4	175
		3"	FWS-450-3	175
	4.50	4"	FWS-450-4	175
		4"	FWS-600-4	175
6"	6.00	6"	FWS-600-6	175
		4"	FWS-663-4	175
	6.63	6"	FWS-663-6	175
		4"	FWS-800-4	175
8"	8.00	6"	FWS-800-6	175
		8"	FWS-800-8	175
		4"	FWS-863-4	175
	8.63	6"	FWS-863-6	175
		8"	FWS-863-8	175
		6"	FWS-1000-6	175
10"	10.00	8"	FWS-1000-8	175
		10"	FWS-1000-10	175
		4"	FWS-1075-4	175
	10.75	6"	FWS-1075-6	175
		8"	FWS-1075-8	175
		10"	FWS-1075-10	175
12"	12.00	8"	FWS-1200-8	175
		10"	FWS-1200-10	175
		12"	FWS-1200-12	175
	12.75	4"	FWS-1275-4	175
		6"	FWS-1275-6	175
		8"	FWS-1275-8	175
		10"	FWS-1275-10	175
		12"	FWS-1275-12	175

Larger sizes available. Please contact factory for more information. See catalog section AA for bolt-on style tapping sleeves.



# Ford Miscellaneous Steel Fittings

The following fittings are commonly used for plant installation and can be modified for specialized requirements. Use the drawings below as a reference when requesting a quotation. All fabricated steel fittings will conform to dimensions tables in AWWA C208.

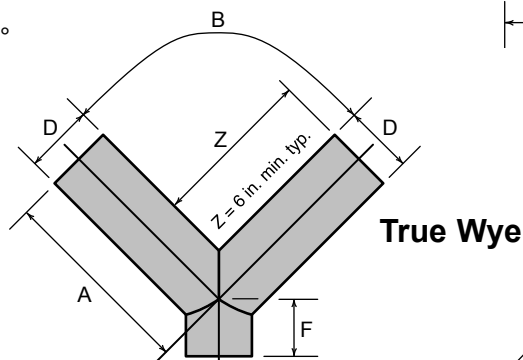
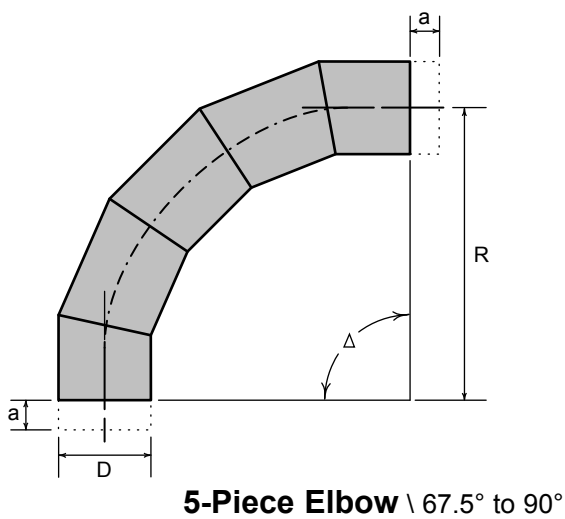
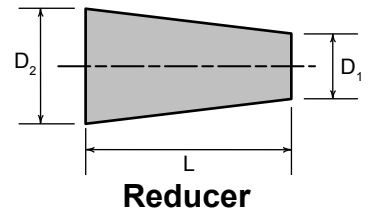
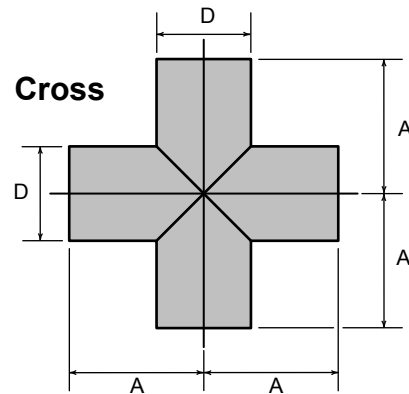
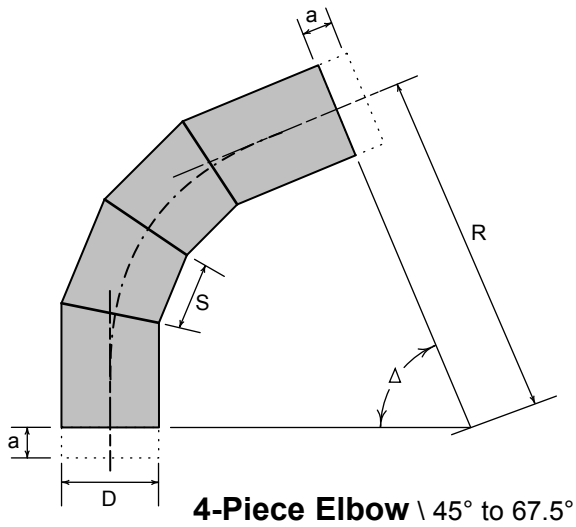
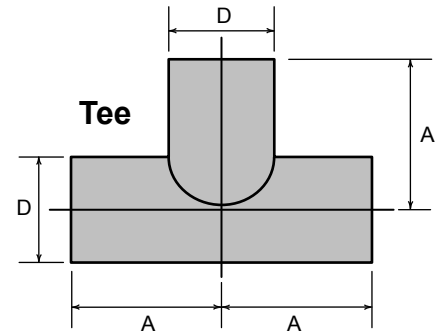
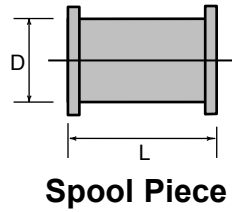
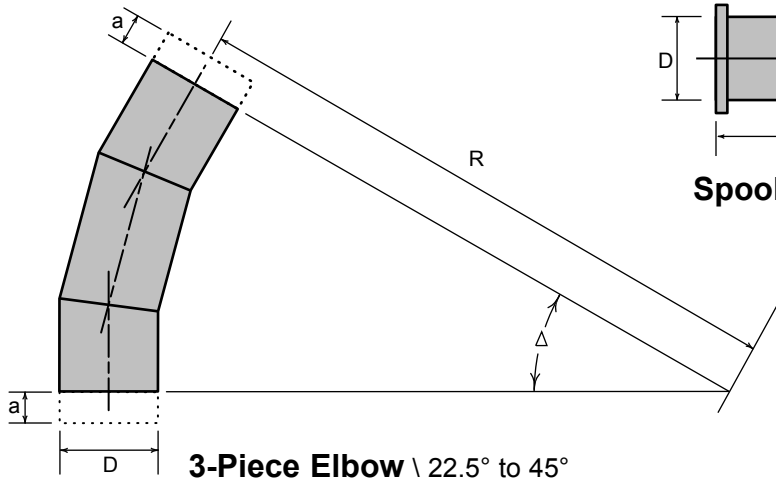

**Lateral**  
45° min; 75° max

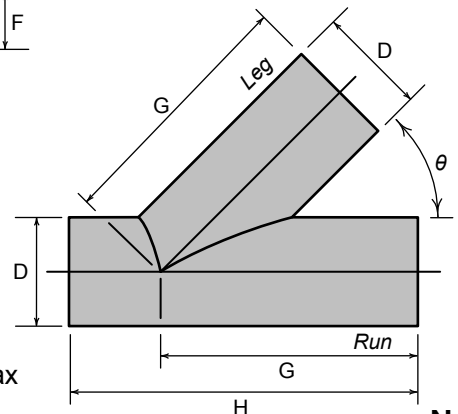

# Stainless Steel Inserts

For HDPE Pipe



Ford stainless steel inserts prevent HDPE pipe from losing rigidity on the end while also keeping the gasket or restraint functioning properly on the pipe. With one end tapered and a lip on the other, the solid design is easy to install and can't be over-inserted.

## Features:

- Solid design on 6" and larger sizes. 3" and 4" design may be solid or wedged.
- Type 304 stainless steel per ASTM A240 (with optional 316 stainless steel)
- Chemically passivated to restore natural corrosion-resistant state
- Durable, ergonomic design allows for a simple installation and long-lasting life

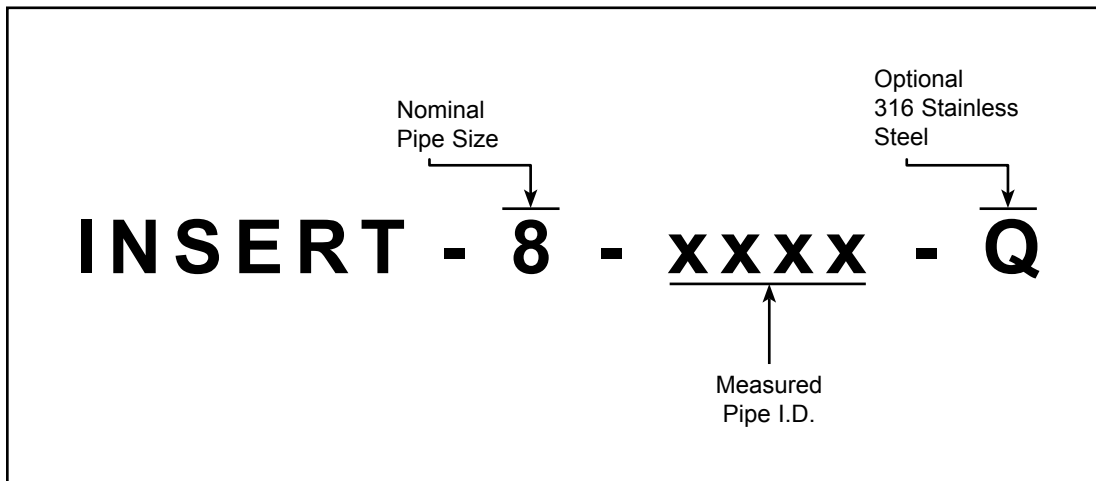

NOM. PIPE SIZE	*CATALOG NUMBER	LENGTH	GAUGE / THICKNESS	APPROX. WT. LBS.
3"	INSERT-3-xxx	6" - 8"	14	1.7
4"	INSERT-4-xxx		20	1.0
6"	INSERT-6-xxx	7-3/8"	18	2.1
8"	INSERT-8-xxx		18	2.8
10"	INSERT-10-xxxx		18	3.5
12"	INSERT-12-xxxx		18	4.1
14"	INSERT-14-xxxx		16	5.7
16"	INSERT-16-xxxx		16	6.5
18"	INSERT-18-xxxx		16	7.4
20"	INSERT-20-xxxx		16	8.2
24"	INSERT-24-xxxx		16	9.6
30"	INSERT-30-xxxx		12	20.4
36"	INSERT-36-xxxx		12	25.0

\* When ordering, the pipe inside diameter is required. For example, when ordering for an 8" pipe with an I.D. of 7.305", the part number is INSERT-8-7305.

Contact factory for sizes larger than 36" or high pressure applications.

# O.D. Chart

PIPE SIZE	PVC/HDPE (STEEL SIZE) O.D.	PVC/HDPE C900 O.D.	DUCTILE / CAST IRON			ASBESTOS-CEMENT			STEEL		COPPER
			CLASSES		O.D.	CLASS	MACHINED END O.D.	ROUGH BARREL O.D. MIN - MAX	Type	O.D.	O.D.
			PIT	SPUN							
1/2"	.84								STD.	.84	.625
3/4"	1.05								STD.	1.05	.875
1"	1.32								STD.	1.32	1.125
1-1/4"	1.66								STD.	1.66	1.375
1-1/2"	1.90								STD.	1.90	1.625
2"	2.38				2.50				STD.	2.38	2.125
2-1/2"	2.88								STD.	2.88	2.625
3"	3.50		A		3.80	100	3.74	4.00	O.D.	3.00	3.125
			B, C, D	50 - 350	3.96	150	3.84	4.10	STD.	3.50	
						200	3.84	4.29			
3-1/2"								STD.	4.00	3.625	
4"	4.50	4.80	A	50 - 350	4.80	100	4.64	4.79 - 5.14	O.D.	4.00	4.125
			B, C, D		5.00	150	4.81	4.97 - 5.27	STD.	4.50	
						200	4.81	5.22 - 5.57			
4-1/2"								STD.	5.00		
5"								STD.	5.56	5.125	
6"	6.63	6.90	A	50 - 350	6.90	100	6.91	7.05 - 7.40	O.D.	6.00	6.125
			B, C, D,		7.10	150	6.91	7.07 - 7.37	STD.	6.63	
			E, F		7.22	200	6.91	7.26 - 7.56			
7"								STD.	7.63		
8"	8.63	9.05	A, B,	50 - 300	9.05	100	9.11	9.22 - 9.57	O.D.	8.00	
			C, D,	350	9.30	150	9.11	9.27 - 9.57	STD.	8.63	
			E, F		9.42	200	9.11	9.39 - 9.74			
9"								STD.	9.63		
10"	10.75	11.10	A, B,	50 - 200	11.10	100	11.24	11.42 - 11.77	O.D.	10.00	
			C, D,	250 - 350	11.40	150	11.66	11.82 - 12.12	STD.	10.75	
			E, F		11.60	200	11.66	11.77 - 12.12			
12"	12.75	13.20	A, B,	50 - 200	13.20	100	13.44	13.69 - 14.04	O.D.	12.00	
			C, D,	250 - 350	13.50	150	13.92	14.08 - 14.38	STD.	12.75	
			E, F		13.76	200	13.92	14.03 - 14.38			
14"	14.00	15.30	A, B,	50 - 100	15.30	100	15.07	15.40 - 15.80	STD.	14.00	
			C, D,	150 - 300	15.65	150	16.22	16.38 - 16.73			
			E, F		15.98	200	16.22	16.48 - 16.88			
16"	16.00	17.40	A, B,	50 - 100	17.40	100	17.14	17.54 - 17.94	STD.	16.00	
			C, D,	150 - 300	17.80	150	18.46	18.62 - 18.97			
			E, F		18.16	200	18.46	18.79 - 19.19			
18"	18.00	19.50	A, B	50 - 100	19.50	100	19.90	20.44	STD.	18.00	
			C, D	150 - 250	19.92	150	20.94	21.20			
						200	22.18				
20"	20.00	21.60	A, B,	50 - 100	21.60	100	22.12	22.50	STD.	20.00	
			C, D	150 - 250	22.06	150	23.28	23.54			
						200	24.66				
22"								STD.	22.00		
24"	24.00	25.80	A, B,	50 - 100	25.80	100	26.48	27.17	STD.	24.00	
			C, D	150 - 250	26.32	150	27.96	28.22			
						200	29.62				
30"	30.00	32.00	A		31.74				STD.	30.00	
			B	50 - 350	32.00						
			C		32.40						
			D		32.74						
36"	36.00	38.30	A		37.96				STD.	36.00	
			B	50 - 350	38.30						
			C		38.70						
			D		39.16						
42"		44.50	A		44.20				STD.	42.00	
			B	50 - 350	44.50						
			C		45.10						
			D		45.58						
48"		50.80	A		50.50				STD.	48.00	
			B	50 - 350	50.80						
			C		51.40						
			D		51.98						
54"			A		56.66				STD.	54.00	
			B		57.10						
				50 - 350	57.56						
			C		57.80						
60"			D		58.40				STD.	60.00	
				50 - 350	61.61						
			A		62.80						
			B		63.40						
			C		64.20						
			D		64.82						

**Note:** Due to variations in outside diameters and specifications, dimensions listed above are approximate. For this reason, determine the pipe O.D. before ordering.

# Section **N**

# Ford Fabricated Steel Products

## Warranty

All merchandise is warranted to be free from defects in material and factory workmanship for one year from date of shipment from our factory. We will provide, free of charge, new products in equal quantities for any that prove defective within one year from date of shipment from our factory. Manufacturer shall not be liable for any loss, damage, or injury, direct or consequential, arising out of the use of or the inability to use the product. Before using, user shall determine the suitability of the product for user's intended use and user assumes all risk and liability whatever in connection therewith. No claims for labor or consequential damage will be allowed. The foregoing may not be changed except by agreement signed by an officer of the manufacturer.

No other warranties are applicable or may be implied, including the implied warranty of merchantability and the implied warranty of fitness for particular purpose and any warranty relating to infringement or the like, all of which are disclaimed.

### Please Note:

Consult The Ford Meter Box Company, Inc. website ([www.fordmeterbox.com](http://www.fordmeterbox.com)) for the most recent catalog information. The Ford Meter Box Company considers the information in this catalog to be correct at the time of publication. Items and option availability, including specifications, are subject to change without notice. Please verify that your product information is current.



**The Ford Meter Box Co., Inc.** 775 Manchester Avenue, P.O. Box 443, Wabash, Indiana, USA 46992-0443  
Telephone: 260/563-3171 FAX: 1-800-826-3487 Overseas FAX: 260/563-0167 [www.fordmeterbox.com](http://www.fordmeterbox.com)

