

SUBMITTAL INFORMATION

Repair Clamps - (FS1-xxx-Length style)

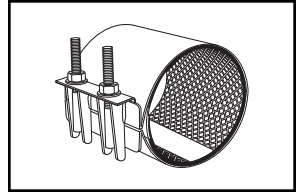

2" TO 4" ALL STAINLESS STEEL CIRCLE REPAIR CLAMPS

Optional Stainless Taps
ASTM A240 type 304 stainless steel tig welded to band. Available with AWWA or I.P. threads.

Band
ASTM A240 type 304 stainless steel

Lifter Bar
ASTM A240 type 304 heavy gauge stainless steel

Sidebar
ASTM A240 type 304 heavy gauge stainless steel

Lug
ASTM A240 type 304 heavy gauge stainless steel

Armor
ASTM A240 type 304 heavy gauge stainless steel, mold bonded into the gasket to ensure uniform compression against the pipe

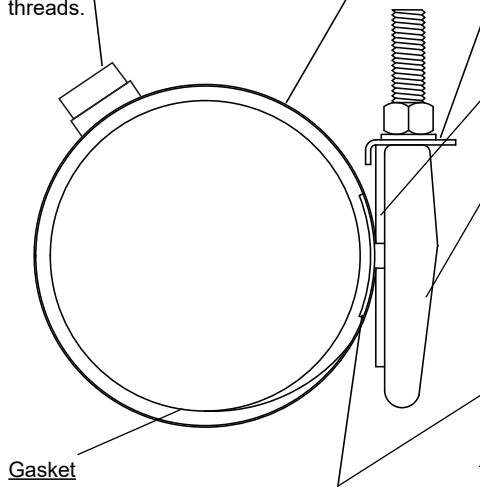

Gasket

Gridded virgin SBR compounded for water service, per ASTM D2000. Buna-N Nitrile is optional.

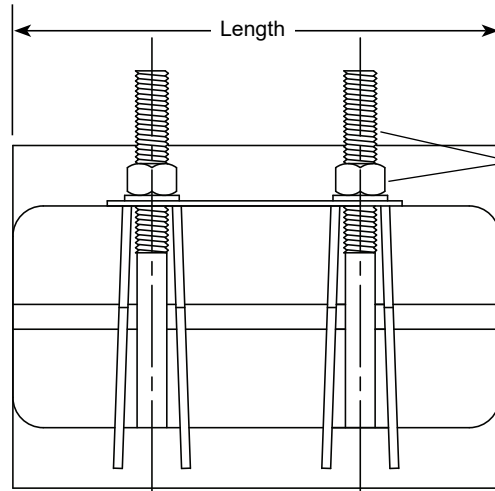

Bolts & Nuts
ASTM A240 type 304 stainless steel nuts and washers. Nuts are coated to prevent galling.

OUTLET THREAD TAP CODE

| CC (AWWA) Thread | | | IP Thread | | |
|------------------|-------------|----------------|-----------|-------------|----------------|
| THREAD | CODE NUMBER | MIN. CLAMP SZ. | THREAD | CODE NUMBER | MIN. CLAMP SZ. |
| 3/4" CC | -CC3 | 2.63 | 3/4" IP | -IP3 | 2.63 |
| 1" CC | -CC4 | 2.63 | 1" IP | -IP4 | 2.63 |
| 1-1/4" CC | -CC5 | 3.70 | 1-1/4" IP | -IP5 | 3.70 |
| 1-1/2" CC | -CC6 | 4.25 | 1-1/2" IP | -IP6 | 3.70 |
| 2" CC | -CC7 | 4.73 | 2" IP | -IP7 | 4.25 |

| NOM. PIPE SIZE | PIPE O.D. RANGE | LENGTH AND APPROXIMATE WEIGHT (LBS.) | | | | | | | | | | BOLT SIZE | BAND THICKNESS | CATALOG NUMBER FS1-XXX-LENGTH | ✓ SUBMITTED ITEM(S) | |
|-----------------|-----------------|--------------------------------------|----|------|-----|-------|-----|-----|-----|-----|----------------|-----------|----------------|-------------------------------|---------------------|--|
| | | 4" | 6" | 7.5" | 10" | 12.5" | 15" | 20" | 24" | 30" | | | | | | |
| 2" | 2.05 - 2.25 | 3 | 4 | 4 | 5 | 5 | 8 | n/a | n/a | n/a | 1/2" 13 UNC | 24 GA. | FS1-225- | | | |
| | 2.35 - 2.63 | N/A | 4 | 4 | 5 | 5 | 8 | n/a | n/a | n/a | | | FS1-263- | | | |
| 2-1/4" - 2-1/2" | 2.70 - 3.00 | N/A | 4 | 5 | 5 | 6 | 8 | n/a | n/a | n/a | | | FS1-300- | | | |
| | 2.97 - 3.25 | | | | | | | | | | | | FS1-325- | | | |
| | 3.42 - 3.66 | N/A | 4 | 5 | 5 | 6 | 9 | n/a | n/a | n/a | | | FS1-366- | | | |
| | 3.46 - 3.70 | | | | | | | | | | | | FS1-370- | | | |
| | 3.73 - 4.00 | | | | | | | | | | | | FS1-400- | | | |
| | 3.96 - 4.25 | | | | | | | | | | | | FS1-425- | | | |
| 3" | 4.06 - 4.35 | N/A | 5 | | | | | | | | | | 5/8" 11 UNC | 24 GA. | FS1-435- | |
| | 4.37 - 4.65 | | | | | | | | | | | | | | FS1-465- | |
| | 4.45 - 4.73 | | | | | | | | | | FS1-473- | | | | | |
| | 4.50 - 4.80 | | | | | | | | | | FS1-480- | | | | | |
| | 4.74 - 5.14 | | | | | | | | | | FS1-514- | | | | | |
| | 4.95 - 5.35 | N/A | 5 | | 7 | 8 | 10 | 14 | 16 | 21 | FS1-535- | | | | | |
| | 5.22 - 5.62 | | | | | | | | | | FS1-562- | | | | | |
| | Number of Bolts | | 1 | 2 | 2 | 3 | 3 | 4 | 6 | 6 | 9 | | | | | |

FEATURES

- Buna-N gasket and conductivity strips are available
- Also available in two-and three-section clamps for a wider range of pipe sizes and tolerances
- Optional outlet taps are available for repair of service line pull-outs. Add tapping code to catalog number
- All welds are fully passivated to restore corrosion resistant characteristics of stainless steel
- UL classified to ANSI/NSF Standard 61

The Ford Meter Box Company considers the information in this submittal form to be correct at the time of publication. Item and option availability, including specifications, are subject to change without notice. Please verify that your product information is current.



The Ford Meter Box Company, Inc.
P.O. Box 443, Wabash, Indiana U.S.A. 46992-0443
Phone: 260-563-3171 / Fax: 800-826-3487
Overseas Fax: 260-563-0167
www.fordmeterbox.com

11/07/16

Submitted By:



36 Hudson Rd
Sudbury MA 01776



800-225-4616
www.tisales.com