

SUBMITTAL INFORMATION

Repair Clamps - (FS2-xxxx-Length style)

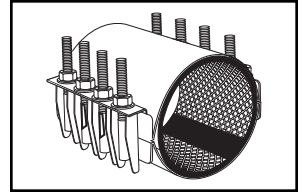

18" TO 20" TWO SECTION WIDER RANGE ALL STAINLESS STEEL REPAIR CLAMPS

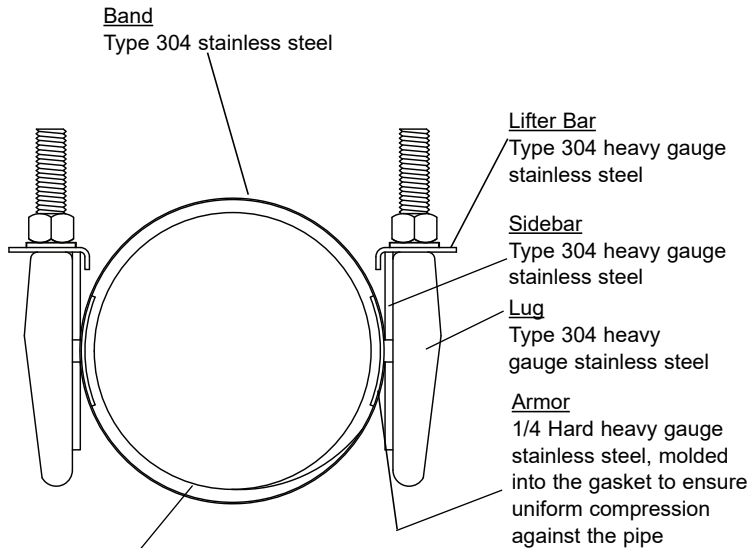

Gasket
SBR per ASTM D2000
Optional NBR (Buna-N) or EPDM

Studs & Nuts

Type 304 stainless steel studs and washers per ASTM A193 and A194. Nuts are coated to prevent galling.

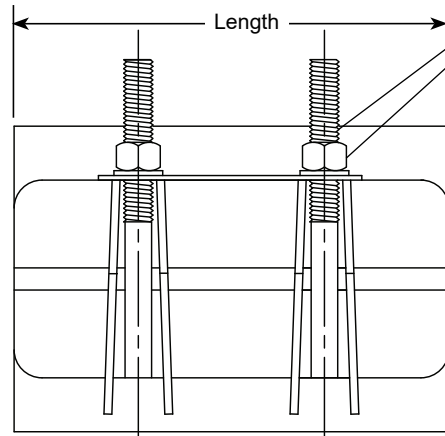

Optional Stainless Taps

Type 304 stainless steel tap TIG welded to band. Available with AWWA, or I.P. threads.

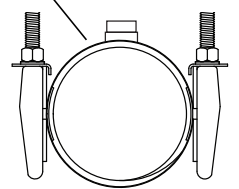

OUTLET THREAD TAP CODE

CC (AWWA) Thread		IP Thread	
THREAD	CODE NUMBER	THREAD	CODE NUMBER
3/4" CC	-CC3	3/4" IP	-IP3
1" CC	-CC4	1" IP	-IP4
1-1/4" CC	-CC5	1-1/4" IP	-IP5
1-1/2" CC	-CC6	1-1/2" IP	-IP6
2" CC	-CC7	2" IP	-IP7

NOM. PIPE SIZE	PIPE O.D. RANGE (IN.)	LENGTH AND APPROXIMATE WEIGHT (LBS.)						BOLT SIZE	CATALOG NUMBER	✓ SUBMITTED ITEM(S)
		10"	12.5"	15"	20"	24"	30"			
18"	19.10 - 19.90	25	32	39	53	65	69	5/8" UNC	FS2-1990-Length	
18"	19.20 - 20.00	25	32	39	53	65	69		FS2-2000-Length	
20"	21.20 - 22.00	27	34	43	55	67	71		FS2-2200-Length	
20"	21.66 - 22.46	27	34	43	55	67	71		FS2-2246-Length	
Number of Studs		6	8	8	12	14	18			

FEATURES

- Gasket is SBR per ASTM D2000. NBR (Buna-N) and EPDM are available.
- Optional outlet taps are available for repair of service line pull-outs. Add tapping code to the catalog number. Example: FS2-2200-125-IP4
- All welds are fully passivated to restore the corrosion resistant characteristics of the stainless steel
- Certified to ANSI/NSF Standard 61

The Ford Meter Box Company considers the information in this submittal form to be correct at the time of publication. Item and option availability, including specifications, are subject to change without notice. Please verify that your product information is current. Our standard warranty applies.



The Ford Meter Box Company, Inc.
P.O. Box 443, Wabash, Indiana U.S.A. 46992-0443
Phone: 260-563-3171 / Fax: 800-826-3487
Overseas Fax: 260-563-0167
www.fordmeterbox.com

09/29/20

Submitted By:



36 Hudson Rd
Sudbury MA 01776



800-225-4616
www.tisales.com