

SUBMITTAL INFORMATION

Stainless Steel Tapping Sleeve 30"-36" - (FTSS-xxxx-xx style)

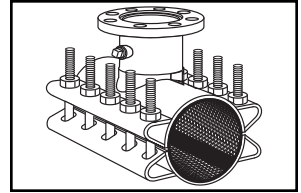

TAPPING SLEEVE WITH STAINLESS STEEL OR CARBON STEEL FLANGE

Flange - Type 304 stainless steel with recess per MSS SP-60 to accept standard tapping valves. Flange conforms to AWWA C228 Class D ANSI 150# drilling. Optional carbon steel flange, per AWWA C207, is available.

Outlet Pipe - Type 304 stainless steel Schedule 10 for 2"-4" outlets. Outlets larger than 4" are Schedule 5.

3/4-14 No-Lead Brass Test Plug

Bolts, Nuts, & Washers - Type 304 stainless steel per ASTM A193 and A194. Heavy hex nuts and washers are coated to prevent galling and maximize bolt efficiency.

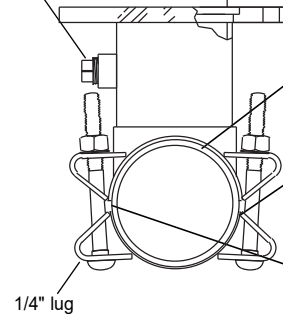
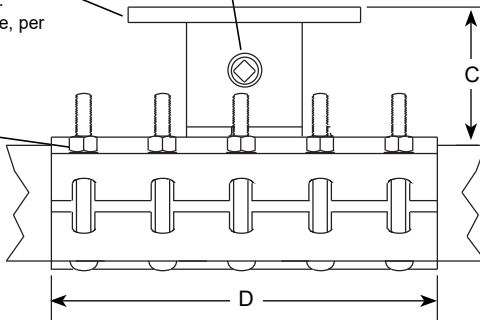

Outlet Gasket - Virgin NBR (Buna-N) compounded for water service, per ASTM D2000. Outlet gasket ensures complete seal of outlet area.

Full Gasket - Gridded virgin SBR compounded for water service, per ASTM D2000. Full gasket gives 360° pipe coverage.

Armors - Hardened heavy gauge stainless steel are vulcanized to gasket and recessed to bridge the gap between lugs.

NOM. PIPE SIZE	SLEEVE O.D. RANGE (IN.)	BY	FLANGE SIZE CODE	NOMINAL DIMENSIONS - INCHES				BOLT SIZE	NO. OF BOLTS	APPROX. WT. LBS.	*SLEEVE NUMBER	✓ SUBMITTED ITEM(S)					
				A	B	C	D										
30"	29.70-30.20		2	3-1/64	2-13/32	5-3/16	16	3/4" x 8-1/2"	10	170	FTSS-3020-xx						
			3	4-1/64	3-15/32	5-3/16	16	3/4" x 8-1/2"	10	212							
			4	5-1/32	4-1/4	5-3/16	16	3/4" x 8-1/2"	10	254		FTSS-3040-xx					
			6	7-1/32	6-5/16	5-3/16	16	3/4" x 8-1/2"	10	192							
			8	9-1/32	8-1/4	5-3/16	16	3/4" x 8-1/2"	10	209			FTSS-3222-xx				
			10	11-1/32	10-1/4	5-3/16	20	3/4" x 8-1/2"	12	274							
			12	13-1/32	12-1/4	5-3/16	24	3/4" x 8-1/2"	14	344				FTSS-3227-xx			
			14	15-9/32	13-1/2	6-1/4	24	3/4" x 8-1/2"	14	418							
			16	17-9/32	15-1/2	6-1/4	32	3/4" x 8-1/2"	20	492					FTSS-3280-xx		
			18	19-1/2	17-1/2	6-1/4	36	3/4" x 8-1/2"	24	552							
			20	20-1/2	19-1/2	6-1/4	40	3/4" x 8-1/2"	24	623						FTSS-3300-xx	
			24	25-1/2	23-1/2	6-1/4	48	3/4" x 8-1/2"	28	747							
30	31-1/64	30-3/16	6-1/8	60	3/4" x 8-1/2"	36	1067	FTSS-3360-xx									
36"	34.60-35.10		3	4-1/64	3-15/32	5-3/16	16		3/4" x 8-1/2"	10	254						FTSS-3510-xx
			4	5-1/32	4-1/4	5-3/16	16		3/4" x 8-1/2"	10	256						
			6	7-1/32	6-5/16	5-3/16	16		3/4" x 8-1/2"	10	260	FTSS-3620-xx					
			8	9-1/32	8-1/4	5-3/16	20		3/4" x 8-1/2"	10	266						
			10	11-1/32	10-1/4	5-3/16	20		3/4" x 8-1/2"	12	315		FTSS-3660-xx				
			12	13-1/32	12-1/4	5-3/16	24		3/4" x 8-1/2"	16	397						
			14	15-9/32	13-1/2	6-1/4	24		3/4" x 8-1/2"	14	472			FTSS-3830-xx			
			16	17-9/32	15-1/2	6-1/4	32		3/4" x 8-1/2"	20	507						
			18	19-1/2	17-1/2	6-1/4	36		3/4" x 8-1/2"	24	630				FTSS-3870-xx		
			20	20-1/2	19-1/2	6-1/4	40		3/4" x 8-1/2"	24	735						
			24	25-1/2	23-1/2	6-1/4	48		3/4" x 8-1/2"	28	836					FTSS-3910-xx	
			30	31-1/64	30-3/16	6-1/8	60	3/4" x 8-1/2"	36	1033							
36	37-1/64	36-3/16	6-1/8	72	3/4" x 8-1/2"	36	1150										

* The complete FTSS catalog number for a 30" pipe (32.00 O.D.) with a 16" stainless steel flange is FTSS-3222-12. For carbon steel flange, add "A" to the catalog number. Example: FTSS-3222-12A.

Note: A 1" undersize cutter is required for flanges 14" and larger. Oversize outlets are available by special request.

Note: Sleeves with 14" and larger flanges have at least two longer starting bolts

FEATURES

- Body, straps and UNC threaded bolts are made of type 304 stainless steel. Flange can be either type 304 stainless steel or ASTM A36 carbon steel. All welds are fully passivated for corrosion resistance.
- Outlet gasket is NBR (Buna-N) per ASTM D2000.
- Other sizes and ranges available. Contact your Ford Meter Box representative for details.
- Certified to ANSI/NSF Standard 61

The Ford Meter Box Company considers the information in this submittal form to be correct at the time of publication. Item and option availability, including specifications, are subject to change without notice. Please verify that your product information is current. Our standard warranty applies.



The Ford Meter Box Company, Inc.
 P.O. Box 443, Wabash, Indiana U.S.A. 46992-0443
 Phone: 260-563-3171 / Fax: 800-826-3487
 Overseas Fax: 260-563-0167
 www.fordmeterbox.com

08/21/20

Submitted By:



36 Hudson Rd
 Sudbury MA 01776



800-225-4616
 www.tisales.com