

SUBMITTAL INFORMATION

Stainless Steel Tapping Sleeve 4"-12" - (FTSS-xxx-x style)

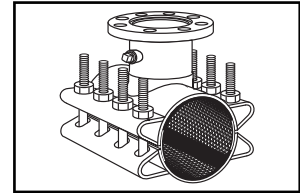

TAPPING SLEEVE WITH STAINLESS STEEL OR CARBON STEEL FLANGE

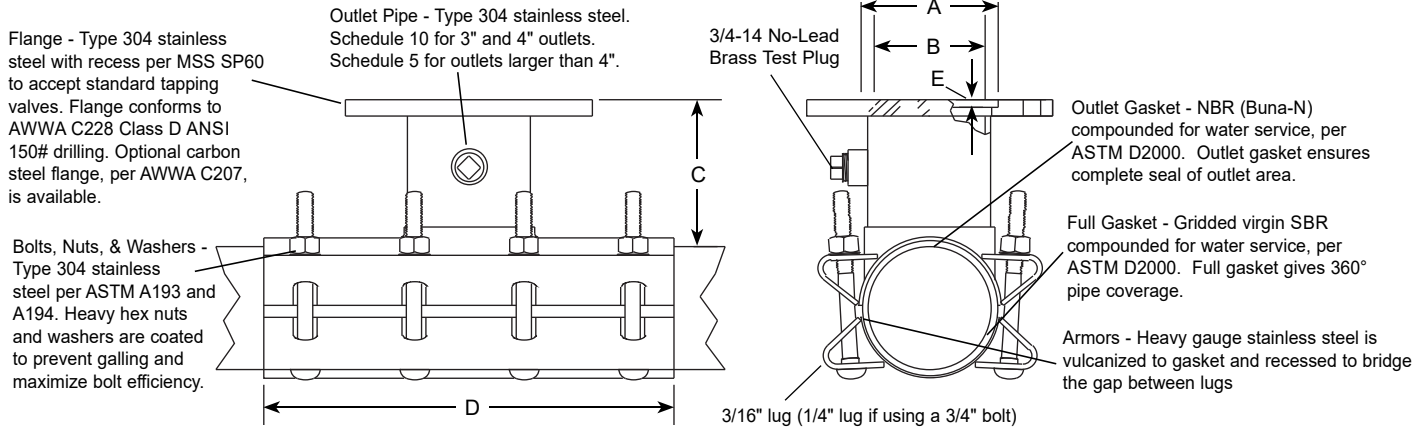

| NOM. PIPE SIZE | SLEEVE O.D. RANGE (IN.) | CATALOG NUMBER | BY | FLANGED OUTLET SIZE* | APPROX. WT. (LBS.) | NOMINAL DIMENSIONS - INCHES | | | | | SADDLE THICKNESS (GAUGE) | STRAP THICKNESS (GAUGE) | BOLT SIZE | ✓ SUBMITTED ITEM(S) | | |
|----------------|-------------------------|----------------|----|----------------------|--------------------|-----------------------------|-----------|---------|-----|-----|--------------------------|-------------------------|-------------|---------------------|--|--|
| | | | | | | A | B | C | D | E | | | | | | |
| 4" | 4.50-4.80 | FTSS-480-x | X | 3" | 36 | 4-1/64" | 3-1/4" | 5-3/16" | 15" | .28 | .105" (12) | .075" (14) | 5/8"x6-1/2" | | | |
| | 4.80-5.00 | FTSS-500-x | | | | 5-1/64" | 4-1/4" | 5-3/16" | 15" | .28 | | | | | | |
| | 5.10-5.30 | FTSS-530-x | | | | 5-1/64" | 4-1/4" | 5-3/16" | 15" | .28 | | | | | | |
| | 5.20-5.40 | FTSS-540-x | | | | 5-1/64" | 4-1/4" | 5-3/16" | 15" | .28 | | | | | | |
| 6" | 6.60-7.00 | FTSS-700-x | X | 3" | 40 | 4-1/64" | 3-1/4" | 5-3/16" | 15" | .28 | | | | | | |
| | 6.90-7.30 | FTSS-730-x | | | | 5-1/64" | 4-1/4" | 5-3/16" | 15" | .28 | | | | | | |
| | 7.30-7.50 | FTSS-750-x | | | | 7-1/64" | 6-13/32" | 5-1/2" | 15" | .34 | | | | | | |
| 8" | 8.63-9.05 | FTSS-905-x | X | 3" | 40 | 4-1/64" | 3-1/4" | 5-3/16" | 15" | .28 | | | | | | |
| | 8.97-9.45 | FTSS-945-x | | | | 5-1/64" | 4-1/4" | 5-3/16" | 15" | .28 | | | | | | |
| | 9.30-9.60 | FTSS-960-x | | | | 7-1/64" | 6-13/32" | 5-1/2" | 15" | .34 | | | | | | |
| | 9.45-9.75 | FTSS-975-x | | | | 9-1/64" | 8-13/32" | 5-5/8" | 20" | .34 | | | | | | |
| 10" | 10.75-11.10 | FTSS-1110-x | X | 3" | 44 | 4-1/64" | 3-1/4" | 5-3/16" | 15" | .28 | | | | | | |
| | 11.06-11.45 | FTSS-1145-x | | | | 5-1/64" | 4-1/4" | 5-3/16" | 15" | .28 | | | | | | |
| | 11.40-11.70 | FTSS-1170-x | | | | 7-1/64" | 6-13/32" | 5-1/2" | 15" | .34 | | | | | | |
| | 11.85-12.15 | FTSS-1215-x | | | | 9-1/64" | 8-13/32" | 5-5/8" | 20" | .34 | | | | | | |
| | | | | | | 11-1/64" | 10-31/64" | 6-1/8" | 20" | .34 | | | | | | |
| 12" | 12.75-13.20 | FTSS-1320-x | X | 3" | 44 | 4-1/64" | 3-1/4" | 5-3/16" | 15" | .28 | | | | | | |
| | 13.12-13.52 | FTSS-1352-x | | | | 5-1/64" | 4-1/4" | 5-3/16" | 15" | .28 | | | | | | |
| | 13.50-13.80 | FTSS-1380-x | | | | 7-1/64" | 6-13/32" | 5-1/2" | 15" | .34 | | | | | | |
| | 14.10-14.40 | FTSS-1440-x | | | | 9-1/64" | 8-13/32" | 5-5/8" | 20" | .34 | | | | | | |
| | | | | | | 11-1/64" | 10-31/64" | 6-1/8" | 20" | .34 | | | | | | |
| | | | | | | 13-1/64" | 12-27/64" | 6-1/4" | 24" | .34 | | | | | | |

Highlighted ranges are recommended for ductile iron pipe and C900/C905 PVC pipe applications.

* To order: Add flanged outlet size to catalog number. Example: The complete FTSS catalog number for a 6" pipe (6.90 O.D.) with a 4" stainless steel flange is FTSS-730-4. For a carbon steel flange, add "A" to the catalog number. Example: FTSS-730-4A

FEATURES

- Body, straps and UNC threaded bolts are made of type 304 stainless steel. Flange can be either stainless steel or ASTM A36 carbon steel. All welds are fully passivated for corrosion resistance.
- Stainless steel plug available, add "-SP" to part number
- Meets AWWA C223
- Tapping sleeves rated for 250 psi working pressure on 4"-12"
- Certified to ANSI/NSF Standard 61

The Ford Meter Box Company considers the information in this submittal form to be correct at the time of publication. Item and option availability, including specifications, are subject to change without notice. Please verify that your product information is current. Our standard warranty applies.



The Ford Meter Box Company, Inc.
 P.O. Box 443, Wabash, Indiana U.S.A. 46992-0443
 Phone: 260-563-3171 / Fax: 800-826-3487
 Overseas Fax: 260-563-0167
 www.fordmeterbox.com

05/05/20

Submitted By:



36 Hudson Rd
 Sudbury MA 01776



800-225-4616
 www.tisales.com