

INSTALLATION INSTRUCTIONS FOR THE FORD FTSS TAPPING SLEEVE

Refer to the Ford website (www.fordmeterbox.com) for additional and most recent installation instructions and product information.

- Your FTSS Tapping Sleeve is warranted to be free of defects at the time of shipment. Please visually inspect before installing to ensure that no damage has occurred during shipment or storage.

Clean any dirt, corrosion, or foreign material from pipe. Measure the pipe diameter and check it against the FTSS range stenciled on the sleeve. Lubricate pipe under and beyond the gasket contact area with a thin coating of pipe joint lubricant.

Note: Extra attention must be given to the lubrication of AC pipe due to its rough and absorbent nature. If it becomes absorbed, apply more lubricant to AC pipe.

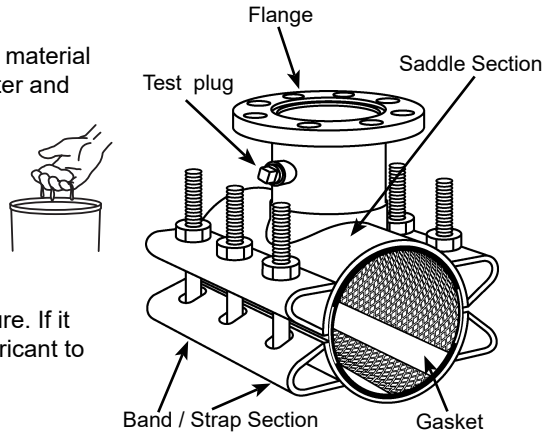

- Place the saddle section of the sleeve on the pipe and **lightly lubricate the outside, smooth surface of the exposed gasket**. Mate the band section with the saddle section on the pipe making sure that the tapered ends of the gasket are not folded or rolled against the pipe. Make sure no foreign material is trapped between the pipe and the gasket. Loosely install the lug bolts, position the sleeve, and hand tighten the nuts to hold the unit in place.

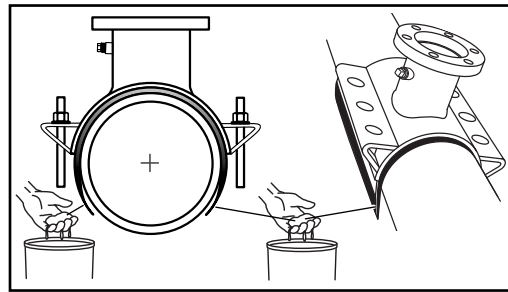

- Begin tightening the bolts using the pattern shown in the diagram below. Make sure the gap between the sleeve sections is equal on top and bottom and equal from end to end.

To achieve proper torque and gap, you must tighten all the bolts several times with incremental torque settings, up to the recommended torque. See table below.

Check final torque several times, including after the tap is made and prior to backfilling. The gasket will continue to compress until it is fully seated. **The use of a torque wrench is recommended and required to ensure proper torque.**

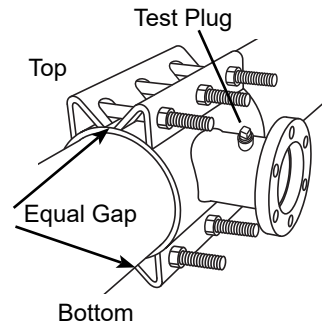

Recommended Torque

Bolt Size	Foot - lbs.
5/8"	75
3/4"	110

Bolt tightening sequence

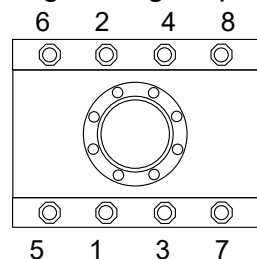

- Use a tapping valve flange gasket, drop-in style that fits inside the bolt circle, or a Ford CSFG style cap gasket to attach the tapping valve to the sleeve. **Apply blocking to support the valve's suspended weight.** The tapping sleeve and valve flanges must mate properly to ensure a straight center line axis. This is necessary to prevent the cutter from hitting the sides of the sleeve outlet.

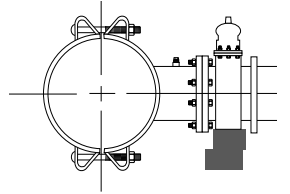

- Test valve and sleeve assembly using the tapping sleeve test port. AWWA C223 recommends "...the installer hydrostatically [water] test the seal between the gasket and pipe. For personal safety reasons, do not use a compressible fluid medium (such as air) to check for water tightness." If a leak is observed, relieve the pressure and re-tighten the bolts to the recommended torque. If the leak continues, remove the tapping sleeve, re-clean and lubricate the pipe and repeat steps 2 and 3 to reset the gasket against the pipe surface.

- Attach the drilling machine to the tapping valve, block, and check for proper mating and alignment between the valve and the machine use blocks and shims.

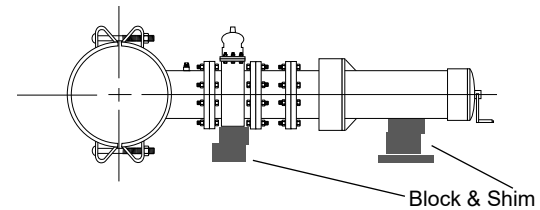

- Make the following checks before proceeding with tap.
 - Gaps between the tapping sleeve saddle and the band sections are equal from side to side and from end to end.
 - All bolts are tightened to the proper torque.
 - All blocking is in place and secure.
 - Valve, tapping sleeve and drilling machine are properly aligned.
 - Correct cutter size has been selected for the job. FTSS sleeves allow a full-sized cutter in outlet sizes 4" -12". **Outlets larger than 12" require a 1" undersized cutter.**

- Re-check tapping sleeve bolt torque after tap and before backfilling. Stresses induced during tapping may relax bolt torque.

- To prevent undue stress on the tapping sleeve and valve assembly, make sure the new water main will rest on a well compacted bed with its center line axis matching the center line axis of the tapping valve.

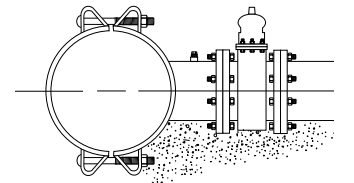

Ti SALES

36 Hudson Rd
Sudbury MA 01776



800-225-4616
www.tisales.com



The Ford Meter Box Co., Inc. P.O. Box 443,
Wabash, IN, USA 46992-0443 Telephone: 260-563-3171
Fax: 800-826-3487 Overseas Fax: 260-563-0167
www.fordmeterbox.com