

# SUBMITTAL INFORMATION

## Stainless Steel Tapping Sleeve 4"-12" - (FTSS-xxx-x-MJ style)

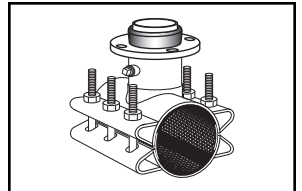

### STAINLESS STEEL TAPPING SLEEVE WITH MECHANICAL JOINT OUTLET

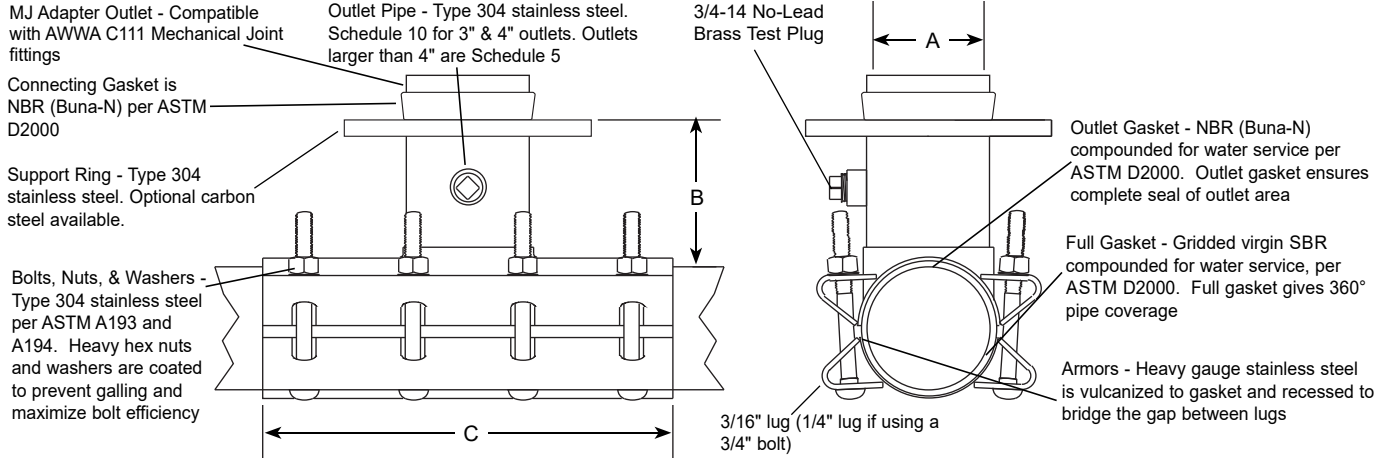

NOM. PIPE SIZE	SLEEVE O.D. RANGE (IN.)	CATALOG NUMBER	BY	OUTLET SIZE/ CODE	APPROX. WT. (LBS.)	NOM. DIMENSIONS - INCHES			SADDLE THICKNESS (GAUGE)	STRAP THICKNESS (GAUGE)	BOLT SIZE	No. BOLTS	✓ SUBMITTED ITEM(S)	
						A	B	C						
4"	4.50-4.80	FTSS-480-x-MJ	X	3	37	3-1/4	5-3/16	15	.105" (12)	.075" (14)	5/8"x6-1/2"	8		
	4.80-5.00	FTSS-500-x-MJ												
	5.10-5.30	FTSS-530-x-MJ		4	38	4-1/4	5-3/16	15						
	5.20-5.40	FTSS-540-x-MJ												
6"	6.60-7.00	FTSS-700-x-MJ	X	3	46	3-1/4	5-3/16	15	.105" (12)	.075" (14)	5/8"x6-1/2"	8		
	6.90-7.30	FTSS-730-x-MJ											4	47
	7.30-7.50	FTSS-750-x-MJ		6	47	6-13/32	5-1/2	15						
8"	8.63-9.05	FTSS-905-x-MJ	X	4	49	4-1/4	5-3/16	15	.105" (12)	.075" (14)	5/8"x6-1/2"	8		
	8.97-9.45	FTSS-945-x-MJ											6	52
	9.30-9.60	FTSS-960-x-MJ		8	71	8-13/32	5-5/8	20						
	9.45-9.75	FTSS-975-x-MJ												
10"	10.75-11.10	FTSS-1110-x-MJ	X	4	47	4-1/4	5-3/16	15	.105" (12)	.075" (14)	5/8"x6-1/2"	8		
	11.06-11.45	FTSS-1145-x-MJ											6	53
	11.40-11.70	FTSS-1170-x-MJ		8	79	8-13/32	5-5/8	20						
	11.85-12.15	FTSS-1215-x-MJ											10	99
12"	12.75-13.20	FTSS-1320-x-MJ	X	4	50	4-1/4	5-3/16	15	.105" (12)	.075" (14)	5/8"x6-1/2"	8		
	13.12-13.52	FTSS-1352-x-MJ											6	55
	13.50-13.80	FTSS-1380-x-MJ		8	86	8-13/32	5-5/8	20						
	14.10-14.40	FTSS-1440-x-MJ											10	104
					12	138	12-27/64	6-1/4					24	3/4"x8-1/2"

Highlighted ranges are recommended for ductile iron pipe and C900/C905 PVC pipe applications.

\*\* To order: Add outlet size to catalog number. Example: The complete FTSS catalog number for a 6" pipe (6.90 O.D.) with a 4" stainless steel outlet is FTSS-730-4-MJ. For a carbon steel outlet, add "A" to the catalog number. Example: FTSS-730-4A-MJ

### FEATURES

- Body, straps and UNC threaded bolts are made of 18-8 stainless steel. Support ring can be either stainless steel or ASTM A36 carbon steel. All welds are fully passivated for corrosion resistance
- Stainless steel plug available, add "-SP" to part number
- Meets AWWA C223
- Tapping sleeves rated for 250 psi working pressure on 4"-12"
- Certified to NSF Standard 61

The Ford Meter Box Company considers the information in this submittal form to be correct at the time of publication. Item and option availability, including specifications, are subject to change without notice. Please verify that your product information is current. Our standard warranty applies.



**The Ford Meter Box Company, Inc.**  
 P.O. Box 443, Wabash, Indiana U.S.A. 46992-0443  
 Phone: 260-563-3171 / Fax: 800-826-3487  
 Overseas Fax: 260-563-0167  
 www.fordmeterbox.com

05/19/21

Submitted By:



36 Hudson Rd  
 Sudbury MA 01776



800-225-4616  
 www.tisales.com