

## AVK SERIES 25/45/55/65/66 RESILIENT SEAT GATE VALVE FIELD MAINTENANCE AND INSTRUCTION MANUAL

### TABLE OF CONTENTS

#### EXPLODED ASSEMBLY / PARTS LIST

#### INTRODUCTION / DESCRIPTION

#### RECEIVING AND STORAGE

- UNLOADING
- INSPECTION AFTER UNLOADING
- STORAGE

#### INSTALLATION AND TESTING

- INSPECTION BEFORE INSTALLATION
- INSTALLATION
- TESTING AFTER INSTALLATION
- APPLICATION HAZARDS

#### OPERATION AND MAINTENANCE

- TOOLS
- OPERATION
- MAINTENANCE PROCEDURES
  - INSPECTION
  - RECORD KEEPING

#### REPAIR PROCEDURES

- NRS VALVES
  - WRENCH NUT/HANDWHEEL REPAIR
  - UPPER STEM SEAL COMPONENTS
  - STEM/WEDGE, LOWER STEM SEAL COMPONENTS
- OS&Y VALVES
  - HANDWHEEL REPLACEMENT
  - STEM SEAL O-RING REPLACEMENT
  - STEM/WEDGE ASSEMBLY REPLACEMENT

#### OPTIONAL EQUIPMENT

- ACTUATOR ADAPTERS
- POST INDICATOR PLATES
- BYPASS

#### TROUBLESHOOTING GUIDE

#### PARTS AND SERVICE

#### WARRANTY

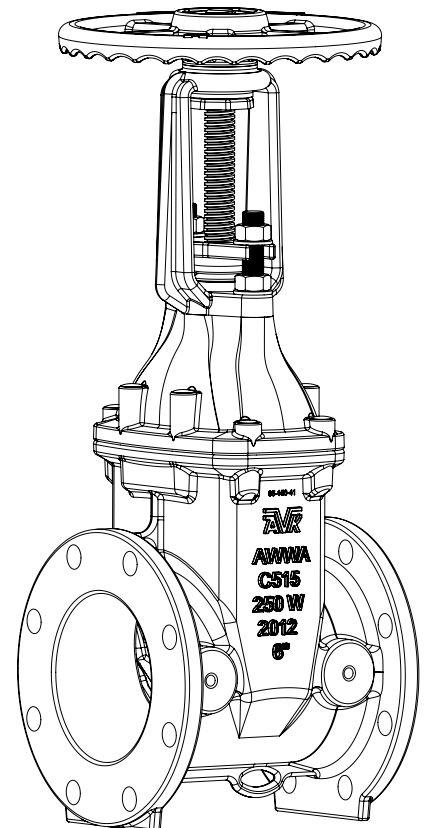
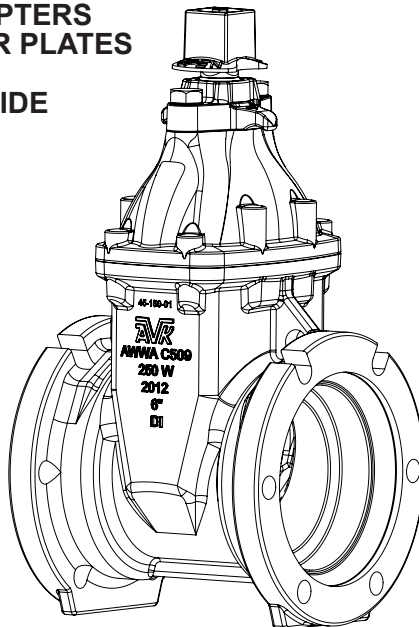

# American AVK Series 25/45/55/65/66 Resilient Seated Gate Valve Exploded Parts Breakdown

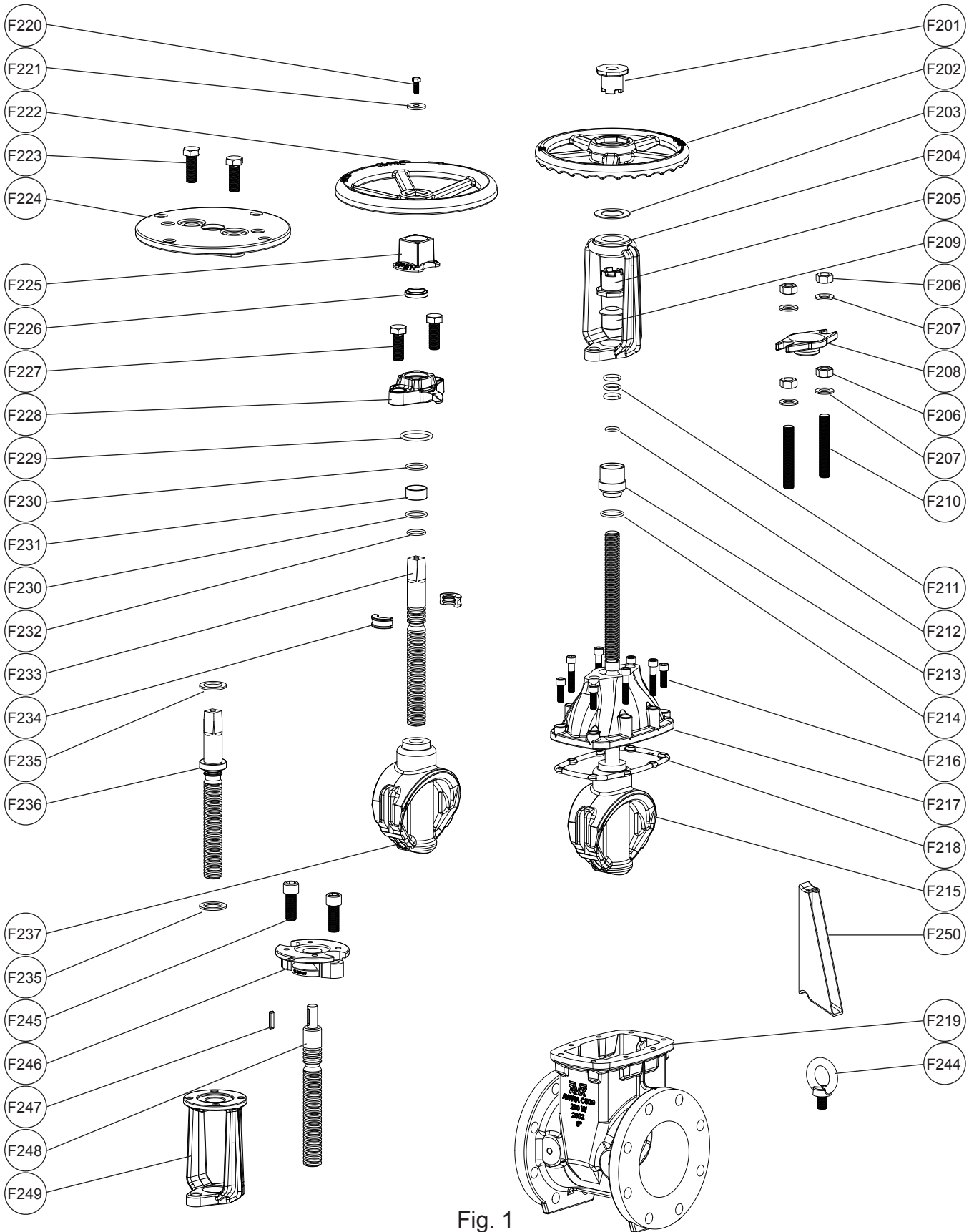

Fig. 1  
page 1

Item No.	Description	Material
F201	Upper Stem Nut	Copper Alloy
F202	OS&Y Handwheel	Grey Iron, ASTM126, Class "B"
F203	Anti Friction Washer	Copper Alloy
F204	Yoke	Ductile Iron, ASTM A536
F205	Lower Stem Nut	Copper Alloy
F206	Gland Follower/Yoke Nut	Zinc Plate, 304 Stainless steel
F207	Gland Follower/Yoke Washer	Zinc Plate, 304 Stainless steel
F208	Gland Follower	Ductile Iron, ASTM A536
F209	Gland	Nylon
F210	Stud Bolt	Zinc Plate, 304 Stainless steel
F211	Stem Seal O-rings	(SBR) Styrene Butadiene Rubber
F212	Inner Bushing O-ring	(NBR) Acrylonitrile Butadiene Rubber
F213	OS&Y Bushing	Nylon
F214	Outer Bushing O-ring	(NBR) Acrylonitrile Butadiene Rubber
F215	OS&Y Stem Assembly Copper Alloy Stem Stainless Steel Stem Wedge Pin Wedge	Copper Alloy 304, 420 Stainless steel 316, Stainless Steel (SBR) Styrene Butadiene Rubber, (EPDM) Ethylene-Propylene-Diene Rubber, Encapsulated Ductile Iron core
F216	Bonnet Bolts	Zinc Plate, 304, 316 Stainless steel
F217	Bonnet (Grey Iron) Bonnet (Ductile Iron)	Grey Iron, ASTM A126, "B" Ductile Iron, ASTM A536
F218	Bonnet Gasket	(NBR) Acrylonitrile Butadiene Rubber
F219	Body (Grey Iron) Body (Ductile Iron)	Grey Iron, ASTM A126, "B" Ductile Iron, ASTM A53
F220	Wrench Nut/Handwheel Bolt	Zinc Plate, 304, 316 Stainless steel
F221	Wrench Nut/Handwheel Washer	Zinc Plate, 304, 316 Stainless steel
F222	NRS Handwheel	Grey Iron, ASTM A126, "B"
F223	Post Indicator Bolts	Zinc Plate, 304, 316 Stainless steel
F224	Post Indicator	Grey Iron, ASTM A126, "B"
F225	Wrench Nut	Grey Iron, ASTM A126, "B"
F226	Wiper Ring	(NBR) Acrylonitrile Butadiene Rubber
F227	Gland Flange Bolt	Zinc Plate, 304, 316 Stainless steel
F228	Gland Flange	Ductile Iron, ASTM A536
F229	Gland O-ring	(NBR) Acrylonitrile Butadiene Rubber
F230	Upper Stem Seal O-rings	(NBR) Acrylonitrile Butadiene Rubber
F231	Stem Seal Bushing	Nylon
F232	Lower Stem Seal O-ring	(NBR) Acrylonitrile Butadiene Rubber
F233	Stainless NRS Stem	420,440 Stainless steel
F234	Thrust Collar	Copper Alloy
F235	NRS Anti-Friction Washer	Nylon
F236	Low Zinc NRS Stem	Copper Alloy
F237	NRS Wedge	(SBR) Styrene Butadiene Rubber, (EPDM) Ethylene-Propylene-Diene Rubber, Encapsulated Ductile Iron core
F238*	Outer O-rings (Series 03)	304 Stainless steel
F239*	Inner O-rings (Series 03)	Polyurethane
F240*	Slide Bearing (Series 03)	304 Stainless steel
F241*	Stem Collar (Series 03)	Mild Steel, 304 Stainless steel
F242*	Stem Seal (Series 03)	304 Stainless steel
F243†	Gasket (Series 45)	(NBR) Acrylonitrile Butadiene Rubber
F244**	Lifting Eye	304 Stainless steel
F245	Actuator Adapter Plate Bolt	304 Stainless steel
F246	Actuator Adapter Plate (NRS)	Ductile Iron, ASTM A536
F247	Stem Key	Mild Steel
F248	Actuator Stem	420 Stainless steel
F249	Actuator Yoke (OS&Y)	Ductile Iron, ASTM A536
F250***	Spool Piece	Ductile Iron, ASTM A536
F251***	Elbow	Ductile Iron, ASTM A536
F252***	Wedge Shoe (Series 55)	Nylon
F253 ††	Retaining Ring (Series 66)	Mild Steel
F254 ††	Shrink Tubing (Series 66)	

\* Series 03 Valves only

\*\* 14"-24" Valves only

\*\*\* Series 55 Valves only

† Series 45 Valves only

†† Series 66 Valves only

## INTRODUCTION / DESCRIPTION

### INTRODUCTION:

American AVK recommends that all water distribution systems have a routine maintenance program established for all components of the water delivery network. For Resilient Seated Gate Valves, we recommend that ANSI/AWWA C509 (latest), Appendix A, as an excellent reference for this.

All American AVK valves are manufactured and tested to ensure trouble free operation. We are so confident of the quality built into all of our products that they come with a 10 Year Warranty against manufacturing and material defects and should, in fact, perform to specification for a much longer period of time.

At this time American AVK has no specific "Maintenance Instructions" for gate valves other than those recommended in the AWWA Publication previously cited. Specific instructions would depend upon the location, installation methods (above ground, buried service, in a vault, etc.), and intended use for each size and end configuration. However we recognize the need for some additional information that is specific to the American AVK product and offer the following to assist you.

In the event of damage to the valve due to foreign material in the system, excessive force being applied when opening or closing the valve, accidental water hammer causing internal damage or other unforeseen incident, the following instructions are provided to assist you in the inspection and repair of the Non-Rising Stem (NRS) valve. Refer to the item numbers listed in (Fig.1). Even though these instructions are based on Flanged by Flanged end connections, the parts and instructions remain the same for all NRS American AVK valves, even though the AVK part numbers may be different for other end connections or other criteria.

For repairs on Outside Stem and Yoke (OS&Y) valves, also refer to (Fig.1).

### DESCRIPTION:

American AVK Company manufactures NRS resilient seated gate valves in sizes from 1 to 24 inches.

Series 03 NPT (National Pipe Thread) end connections:	Sizes 1"-3"
* † Series 25 Grey Iron, MJxMJ (Mechanical Joint by Mechanical Joint)	Sizes 3"-16"
Series 25 Grey Iron, MJxMJ ( Mechanical Joint by Mechanical Joint)	Sizes 2"- 2.5"
Series 25 Grey Iron, IPSxIPS (Iron Pipe Size)	Sizes 2.5"-8"
* † Series 25 Grey Iron, MJxFL (Mechanical Joint by Flanged)	Sizes 4"-12" and 16"
* † Series 25 Grey Iron, FLxFL (Flanged by Flanged)	Sizes 2"-16"
* † Series 25 Grey Iron, POxPO (Push-On by Push-On)	Sizes 4"-12" and 16"
* † Series 25 Grey Iron, POxFL (Push-On by Flange)	Sizes 4"-12" and 16"
Series 45 Ductile Iron, IPS (Iron Pipe Size)	Size 2"
Series 45 Ductile Iron, MJxMJ (Mechanical Joint by Mechanical Joint)	Sizes 4"-16"
Series 45 Ductile Iron, MJxFL (Mechanical Joint by Flanged)	Sizes 3"-16"
Series 45 Ductile Iron, FLxFL (Flanged by Flanged) ANSI B 16.1 Class 125	Sizes 2.5"-16"
Series 45 Ductile Iron, FLxFL (Flanged by Flanged) ANSI B 16.1 Class 250	Sizes 4"-12"
Series 45 Ductile Iron, POxPO (Push-On by Push-On)	Sizes 4"-12" and 16"
Series 45 Ductile Iron, POxFL (Push-On by Flange)	Sizes 4"-12" and 16"
Series 45 Ductile Iron, GRVxGRV (Grooved by Grooved - IPS (Iron Pipe Size)	Sizes 3"-8"
Series 45 Ductile Iron, GRVxFL (Grooved by Flanged - IPS (Iron Pipe Size)	Sizes 3"-8"
Series 45 Ductile Iron, GRVxGRV (Grooved by Grooved - DIPS (Ductile Iron Pipe Size)	Sizes 3"-8"
Series 45 Ductile Iron, GRVxFL (Grooved by Flanged - DIPS (Ductile Iron Pipe Size)	Sizes 3"-8"
Series 55 Ductile Iron, MJxMJ (Mechanical Joint by Mechanical Joint)	Sizes 18"-24"
Series 55 Ductile Iron, MJxFL (Mechanical Joint by Flanged)	Sizes 18"-24"
Series 55 Ductile Iron, FLxFL (Flanged by Flanged) ANSI B 16.1 Class 125	Sizes 18"-24"

## INTRODUCTION / DESCRIPTION

### DESCRIPTION: (continued)

Series 65 Ductile Iron, MJxMJ (Mechanical Joint by Mechanical Joint)	Sizes 3"-12"
Series 65 Ductile Iron, MJxFL (Mechanical Joint by Flanged)	Sizes 3"-12"
Series 65 Ductile Iron, FLxFL (Flanged by Flanged) ANSI B 16.1 Class 125	Sizes 2.5"-12"
Series 65 Ductile Iron, POxPO (Push-On by Push-On)	Sizes 3"-12"
Series 65 Ductile Iron, POxFL (Push-On by Flange)	Sizes 3"-12"

Series 66 Ductile Iron, PExPE (Polyethylene Pipe - DIPS/IPS) Sizes 4"-12"

American AVK Company manufactures OS&Y resilient seated gate valves in sizes from 2.5 to 12 inches.

† Series 25 Grey Iron, FLxFL (Flanged by Flanged) ANSI B 16.1 Class 125 Sizes 2.5"-12"

Series 45 Ductile Iron, FLxFL (Flanged by Flanged) ANSI B 16.1 Class 125	Sizes 2.5"-12"
Series 45 Ductile Iron, FLxFL (Flanged by Flanged) ANSI B 16.1 Class 250	Sizes 4"-12"
Series 45 Ductile Iron, GRVxGRV (Grooved by Grooved - IPS (Iron Pipe Size))	Sizes 3"-8"
Series 45 Ductile Iron, GRVxFL (Grooved by Flanged - IPS (Iron Pipe Size))	Sizes 3"-8"
Series 45 Ductile Iron, GRVxGRV (Grooved by Grooved - DIPS (Ductile Iron Pipe Size))	Sizes 3"-8"
Series 45 Ductile Iron, GRVxFL (Grooved by Flanged - DIPS (Ductile Iron Pipe Size))	Sizes 3"-8"

Series 65 Ductile Iron, FLxFL (Flanged by Flanged) ANSI B 16.1 Class 125 Sizes 2.5"-12"

\* Series 25 valves in 14" and 16" sizes are discontinued. See Series 45 Ductile Iron valves for these sizes. Limited quantities of the Series 25 valves may be available in stock and will be used to fill orders unless otherwise specified or requested.

† Series 25 valves in sizes 3" through 12" are discontinued. See Series 65 Ductile Iron valves for these sizes. This will apply to all flange configurations excluding IPS valves, 2"-2.5" MJxMJ valves, and Cut-In MJxMJ valves.

## **RECEIVING AND STORAGE**

### **UNLOADING:**

All valves should be unloaded carefully. Each valve should be carefully lowered from the truck to the ground; it should not be dropped. In the case of larger valves, or valves with post indicator plates, forklifts or slings around the body of the valve or under the skids should be used for unloading. Only hoists and slings with adequate load capacity to handle the weight of the valve or valves should be used. Hoists should not be hooked into or chains fastened around yokes, gearing, motors, cylinders, or handwheels. American AVK valve sizes 14" through 24" have Lifting Eyes for this purpose. Failure to carefully follow these recommendations is likely to result in damage to the valve or personal injury.

### **INSPECTION AFTER UNLOADING:**

Resilient-seated gate valves should be inspected at the time of receipt for damage in shipment. The initial inspection should verify compliance with specifications, direction of opening, size and shape of the operating nut, number of turns to open or close, and type of end connections. A visual inspection of the seating surfaces should be performed to detect any damage in shipment or scoring of the seating surfaces. Inspection personnel should look for bent stems, cracked parts, loose bolts, missing parts and accessories, and any other evidence of mishandling during shipment. Each valve should be operated through one complete opening-and-closing cycle in the position in which it is to be installed.

### **STORAGE:**

1. Resilient-seated gate valves should be stored in a manner that protects them from the environment, preferably indoors.
2. The valves should be stored with the wedges in the nearly closed position to prevent unnecessary compression of the rubber compound.
3. The resilient wedges should also be protected from sunlight, ozone and chemical exposure.
4. If stored outside, the operating mechanisms, such as gears, motor, actuators, and cylinders should be protected from the elements.
5. In colder climates, valves should be drained and left slightly open before storage. Failure to do so may result in cracking the valve castings.
6. Valves stored outside should be stored with the wedges in the vertical position. If the valves are stored in the horizontal or flat position, rainwater may accumulate in the valve cavity, then freeze and crack the castings.
7. Electric motor actuated valves should never be stored outside.

## INSTALLATION AND TESTING

### INSPECTION PRIOR TO INSTALLATION:

1. Visually inspect each valve for any foreign material in the interior of the valve, and remove it if present.
2. Inspect each valve in a similar manner as described in the "INSPECTION AFTER UNLOADING" section of this manual.

### INSTALLATION:

1. All bolts should be checked for proper tightness and protected by the installer to prevent corrosion, either with a suitable paint or by a polyethylene wrapping.
2. Valves in water distribution lines shall, where practical, be located in easily accessible areas.
3. During installation there is the possibility of foreign materials inadvertently entering the valve. Foreign material can damage the internal working parts during operation of the gate valve. For this reason, gate valves should be installed in the closed position. Each valve should be placed on firm footing in the trench to prevent settling and excessive strain on the connection to the pipe. Piping systems should be supported and aligned to avoid damage to the valve.
4. A valve box or vault should be provided for each valve in a buried-service application. The valve box should be installed so as to not transmit shock loads or stress to the valve. The valve box should be centered over the operating nut of the valve with the box cover flush with the surface of the finished area or such other level as directed as directed by the owner. Valve boxes should be of such design that a traffic load on the top of the box is not transmitted to the valve.
5. Valves buried in unusually deep trenches should have special provisions for operating the valve. Either a riser on the stem to permit use of a normal key or a notation on the valve records that a long key will be required.
6. When valves with exposed gearing or operation mechanisms are buried below ground, a vault designed to allow pipe clearance and prevent settling on the pipe should be provided. The operating nut should be accessible from the top opening of the vault with a valve key. The size of the vault should provide for easy removal of the valve bonnet and internal parts of the valve for purposes of repair. Consideration should be given to the possibility of groundwater and/or surface water and to the need to provide the disposal of such water.
7. Valves installed above ground or in a plant piping system should be supported and aligned to avoid damage to the valves. Valves should not be used to correct the misaligned piping.
8. If installing a larger valve that uses a smaller bypass valve, install a second valve box over the bypass valve operating nut.
9. Tighten the bolts and nuts in the crossover method shown in Fig. 2, to load the pipe and valve evenly and prevent stress on the joints.

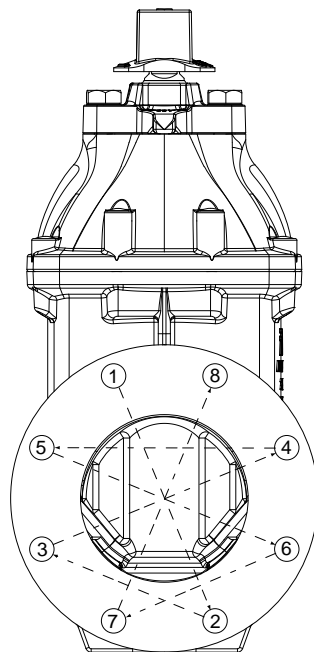

Fig. 2

## INSTALLATION AND TESTING

### TESTING AFTER INSTALLATION:

In order to prevent time searching for leaks, it is recommended that valve excavations not be backfilled until after pressure tests have been made. After installation it is desirable to test newly installed piping sections, including valves, at some pressure above the system designed pressure. The test pressure should not exceed the rated working pressure of the valve. After the test, steps should be taken to relieve any trapped pressure in the body of the valve. The resilient-seated gate valve should not be operated in either the opening or closing direction at differential pressures above the rated working pressure. It should be noted that valves seat better at or near the rated working pressure of the valve. It is also recognized that wear or foreign material may damage valve seating surfaces and may cause leakage.

On completion of the installation, valve location, size, make, type, date of installation, number of turns to open, direction of opening, and other information deemed pertinent should be entered on permanent records.

### APPLICATION HAZARDS:

1. Resilient-seated gate valves should not be installed in lines where service pressure will exceed the rated working pressure of the valve.
2. Resilient-seated gate valves should not be used for throttling service unless the design is specifically recommended for that purpose or approved in advance by the manufacturer.
3. Resilient-seated gate valves should not be used in applications that are exposed to freezing temperatures unless sufficient flow is maintained through the valve or other protection is provided to prevent freezing.
4. Pipe, fittings, and valves installed in underground pipelines are generally joined with push-on or mechanical joints. These joints are considered unrestrained-type joints since no considerable restraint against longitudinal separation is provided.
5. Gate valves should not be installed in a dead end or near a bend in a pipeline without proper and adequate restraint to support the valve and prevent it from blowing off the end of the line.
6. It is good engineering practice to consider during the design whether or not thrust blocks, restrained joints, or other means of restraint are needed on or adjacent to valves on pipelines and/or where unusual conditions exist, such as high internal pressures, adjacent fittings, or unsuitable soils.
7. To prevent damage, 3-in. (75mm) and 4-in. (100mm) NPS resilient-seated gate valves should not be operated with input torques greater than 200 ft-lb (270 Nm). Gate valves 6-in. (150mm) NPS to 16-in. (300mm) NPS should not be operated with input torques greater than 300 ft-lb (406Nm), Gate Valves 18-in. (450mm) NPS to 24-in. (600 mm) should not be operated with input torques greater than 375 ft-lb. Valves equipped with gearing should not be over loaded as this may damage the valve. As a general rule, valves equipped with gearing should not be operated at a torque exceeding 1/3 of the operating torques mentioned above.



## OPERATION AND MAINTENANCE

### TOOLS:

The following tool requirements are listed in both Standard "Inch" sizes as well as "Metric" sizes.

<b>PART</b>	<b>INCH</b>	<b>METRIC</b>
Wrench Nut/Handwheel Retaining Bolts		
2 1/2" - 4" valves	1/2"	13mm
6" - 12" valves	11/16"	17mm
Gland Flange/ Post Indicator Retaining Bolts		
2 1/2" - 4" valves	15/16"	24mm
6" - 12" valves	1 1/4"	30mm
Gland Follower/Yoke Retaining Nuts		
2 1/2" - 4" valves	15/16"	24mm
6" - 12" valves	1 1/4"	30mm
All sizes, Bonnet Bolts	3/8"	10mm

## OPERATION AND MAINTENANCE

### OPERATION:

Each valve should be operated through a full cycle and returned to its normal position on a time schedule designed to prevent a buildup of tuberculation or other deposits that could render the valve inoperable or prevent a tight shutoff. The interval of time between operations of valves in critical locations, or valves subjected to severe operating conditions, should be shorter than for less important installations, but can be whatever time period is found to be satisfactory based on local experience. The number of turns required to complete the operation cycle should be recorded and compared with permanent installation records to ensure full gate travel.

#### American AVK NRS (Non-Rising Stem) Valves - Turns to Open

Valve Size	Turns to Open
1"	7
1.25"	9
1.50"	11
2"	11- *13
2.5"	11- †12
3"	13- †15
4"	14- †17
6"	21- †23
8"	26- †27
10"	32- †33
12"	38- †40
14"	51
16"	51
18"	42
20"	42
24"	51

\* 11 for FLxFL, 13 for IPSxIPS

† Due to a slightly oversized waterway, Series 65 valves have a slightly greater number of turns to open.

#### American AVK OS&Y (Outside Stem and Yoke) Valves - Turns to Open

Valve Size	Turns to Open
2.5"	17
3"	20
4"	21
6"	26
8"	35
10"	37
12"	44

## **OPERATION AND MAINTENANCE**

### **MAINTENANCE PROCEDURES:**

#### **INSPECTION:**

Each valve should be operated through one complete cycle. If the stem action is tight as a result of "hard water" buildup on the stem threads, the operation should be repeated several times until the opening and closing actions are smooth and free. With the gate in the partially open position, a visual inspection should be performed, where practical, to check for leakage at all joints, connections, and areas of packing or seals. If leakage is observed, all defective O-rings, seals, gaskets, or end-connection sealing members should be replaced. If the leakage can not be corrected immediately, the nature of the leakage should be reported promptly to those who are responsible for repairs. If the valve is inoperable or irreparable, its location should be clearly established to save time for repair crews. The condition of the valve, and if possible, the gate position, should be reported to personnel responsible for repairs. In addition, fire departments and other municipal departments should be informed that the valve is out of service.

#### **RECORD KEEPING:**

In order to carry out a meaningful inspection and maintenance program, it is essential that the location, make, type, size, and date of installation of each valve be recorded. Depending on the type of record system used, other information may be entered in the permanent record. When a resilient-seated gate valve is inspected, an entry should be entered in the permanent record indicating the date of inspection and condition of the valve. If repair work is necessary, it should be indicated. On completion of the work, the nature of the repairs and date completed should be recorded.

## REPAIR PROCEDURES

Leakage, broken parts, hard operation, and other major defects should be corrected by a repair crew as soon as possible after the defect has been reported. If repairs are to be performed in the field, the repair crews should take a full complement of spare parts to the jobsite. Provisions should be made to isolate the defective valve from water pressure and relieve internal trapped pressure prior to performing any corrective maintenance. Disassembly of the valve should be accomplished in accordance with the procedure supplied in the following sections. After repairing the valve, the operating mechanism should be cycled through one complete operating cycle. With full line pressure applied to the valve in the open position, an inspection should be made to detect leakage in the areas around the seal plate, bonnet, packing gland, and body-end connections. A record should be made to indicate that the valve has been repaired and is in working condition. Any marking that the valve is inoperable should be removed. In addition, fire department and other appropriate municipal departments should be informed of satisfactory repair of the valve.

### NRS VALVE REPAIRS:

#### WRENCH NUT HANDWHEEL REPAIR:

**WARNING:** Although some of the following procedures can be performed under full working line pressure, it is recommended that any partial disassembly or maintenance be performed with the Water Main Supply Line shut off!

1. Remove the Wrench Nut/ Handwheel Bolt (F220) and Wrench Nut/Handwheel Washer (F221) using a 1/2", (13mm) wrench, for 2 1/2" to 4" valve sizes, and 11/16", (17mm) wrench for 6" to 12" valve sizes. Remove the Wrench Nut (F225) or NRS Handwheel (F222), and replace with a new one. (See Fig.3A, and Fig.3B)
2. Replace the Wrench Nut/ Handwheel Bolt (F220) and Wrench Nut/Handwheel Washer (F221) using a 1/2", (13mm) wrench, for 2 1/2" to 4" valve sizes, and 11/16", (17mm) wrench for 6" to 12" valve sizes

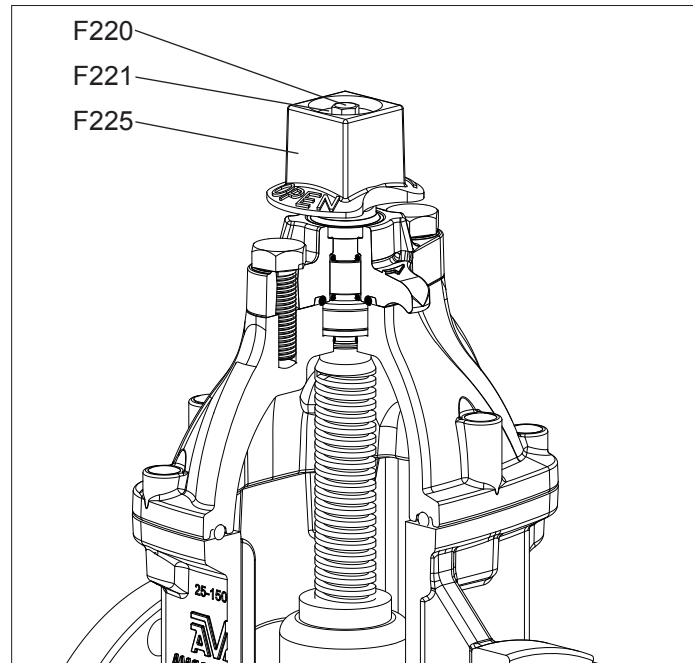

Fig. 3A

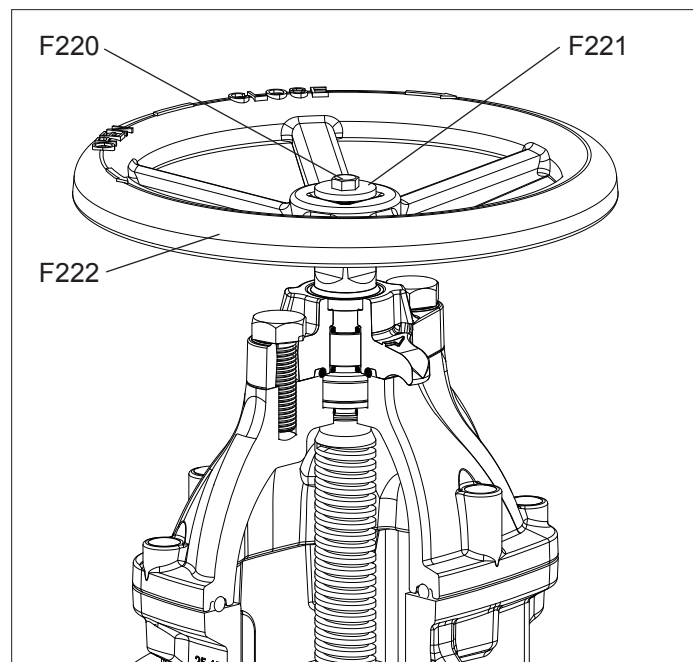

Fig. 3B

## NRS (Non-Rising Stem) VALVE REPAIRS:

### UPPER STEM SEAL COMPONENT REPAIR:

**CAUTION:** With the valve in the fully "OPEN" position, the following procedures can be performed under full working pressure, with no need to shut down the system.

1. Remove the Wrench Nut/ Handwheel Bolt (F220) and Wrench Nut/Handwheel Washer (F221) using a 1/2", (13mm) wrench, for 2 1/2" to 4" valve sizes, and 11/16", (17mm) wrench for 6" to 12" valve sizes. Remove the Wrench Nut (F225) or NRS Handwheel (F222). (See Fig.4)
2. Remove the two Gland Flange Bolts (F227) using a 15/16" or 24mm wrench for valve sizes 2.5"-4", or a 1 1/4" or 30mm wrench for valve sizes 6"-12".
3. Remove the Gland Flange (F228) with Wiper Ring (F226) attached.

**NOTE:** The Wiper Ring (F226) is a "Factory Installed" press fit and therefore must be reordered as an assembly along with the Gland Flange (F228).

4. When performing step 3, verify the location of the Upper Stem Seal O-rings, quantity 2, (F230) and the Stem Seal Bushing (F231). They may be located on the Stem (F233), (See Fig. 4A), or in the counterbore of the Gland Flange (F228), (See Fig. 4B).
5. There is a groove in the bottom of the Gland Flange (F228), for the Gland O-ring (F229). (See Fig. 4B)
6. Inspect and replace any damaged parts. Use a food grade grease that contains no acetate or silicone, on the o-rings. Re-assemble in reverse order.

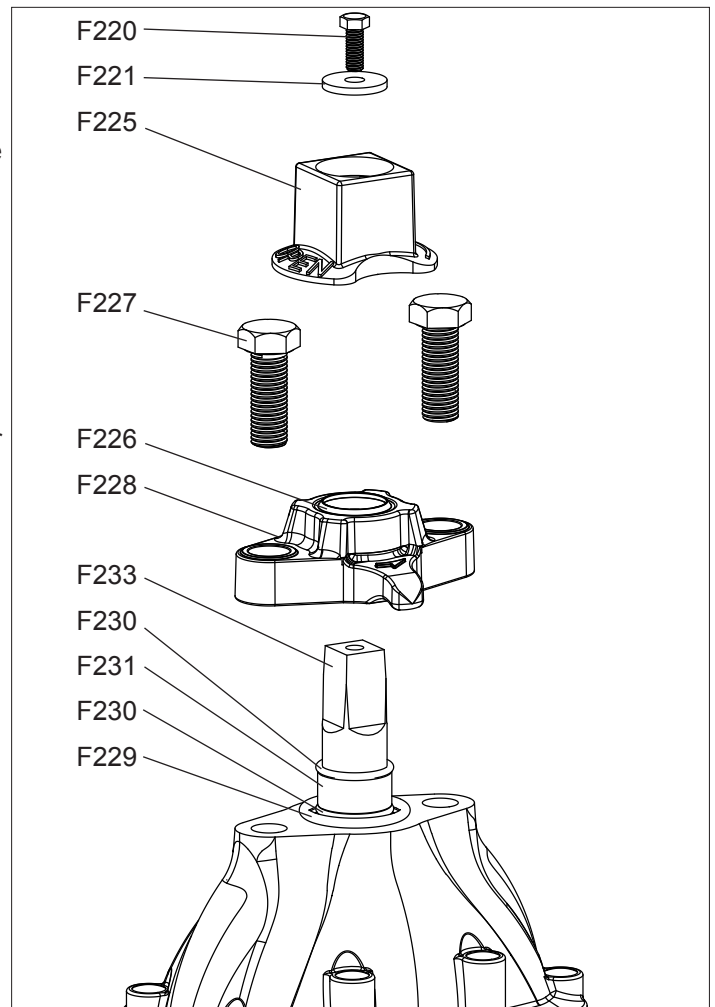

Fig. 4A

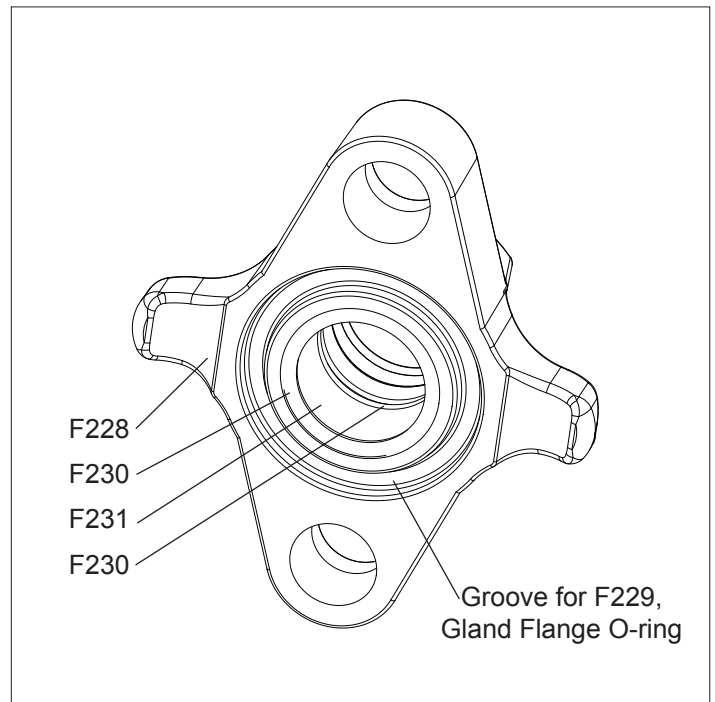

Fig. 4B

## NRS (Non-Rising Stem) VALVE REPAIRS:

### STEM/WEDGE, LOWER STEM SEAL COMPONENT REPAIR:

**WARNING:** To perform the following steps, be sure the Water Main Supply Line has been shut off, and that the pressure has been bled off! Also provide sufficient clearing around the valve so that no soil or debris may fall into it.

1. Complete steps 1 through 4 in the UPPER STEM SEAL COMPONENT REPAIR section.
2. Turn the Stem (F333), in a closing direction until it disengages from the Wedge (F237), and remove from valve.
3. If applicable, for Low Zinc Stems, remove the Lower Anti-Friction Washer (F235) from the recess in the bonnet (F217). For Stainless Steel Stems, the Stem Collar and Anti-Friction Washers are replaced by a two-piece Thrust Collar (F234). No Anti-Friction are necessary or present. The Lower Stem Seal O-ring (F232) should be present on the stem and in its own groove, located directly above the threads.

**NOTE:** On Stainless Steel Stems, the upper three grooves are for locating the Thrust Collar.

4. Inspect and replace any damaged parts.

**NOTE:** Use a food grade grease that contains no acetate or silicone on the new o-rings.

5. Using a small, flat bladed screwdriver, remove the hot melt glue that covers the Bonnet Bolts (F216).
6. Once the hot melt glue has been removed, use a 3/8", or 10mm Allen wrench to remove the Bonnet Bolts (F216). Remove the Bonnet (F217) and Bonnet Gasket (F218) and set aside.
7. To remove the Wedge (F237) it is sometimes helpful to thread the Stem (F233) back into the wedge and use the stem as a handle or lever to extract the wedge. This is helpful with the larger sizes, (10" and 12") valves.
8. Carefully inspect the interior of the valve body and remove any debris.
9. Inspect and replace any damaged parts and re-assemble in reverse order, torquing the Bonnet Bolts to 40 ft. lbs., in a diametrically opposed (180 degrees apart) pattern.
9. To replace the protective hot melt glue over the Bonnet Bolts, use any EPA approved caulk, or hot melt glue.

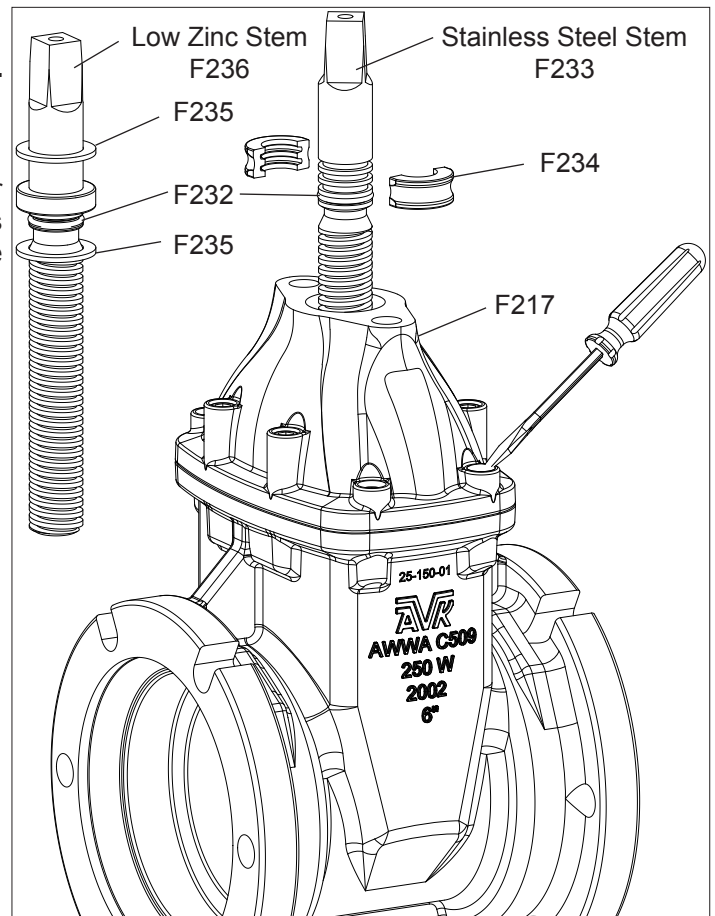

Fig. 5A

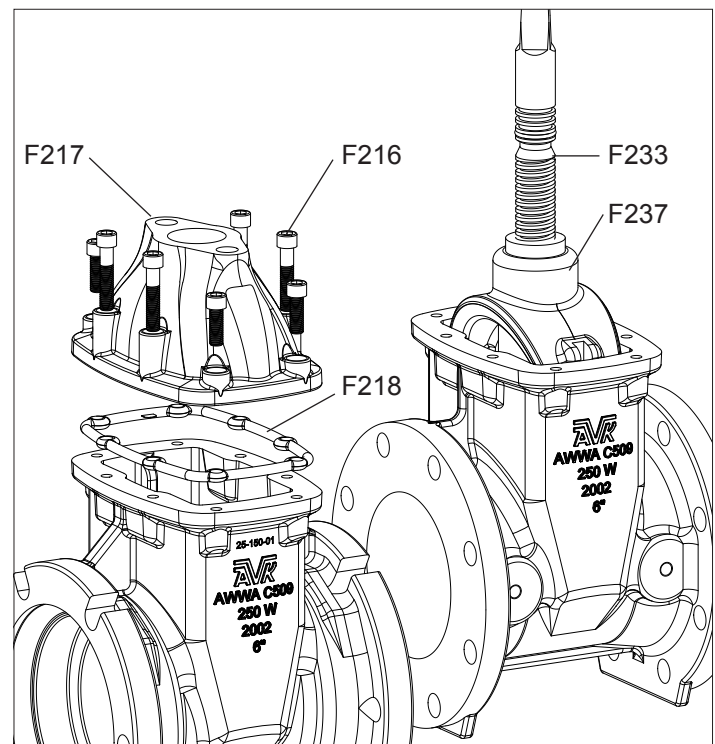

Fig. 5B

## OS&Y (Outside Stem & Yoke) VALVE REPAIRS:

### HANDWHEEL REPLACEMENT (Figs.6A,6B)

**WARNING:** To perform the following steps, be sure the Water Main Supply Line has been shut off, and that the pressure has been bled off! Also provide sufficient clearing around the valve so that no soil or debris may fall into it.

**NOTE:** As most OS&Y valves are used in fire protection applications, verify that any alarm systems have been disabled prior to performing any maintenance or repairs.

1. Remove the two upper Gland Follower / Yoke Nuts (F206), using a 15/16" or 24mm wrench for valve sizes 2.5"-4", or a 1 1/4" or 30mm wrench for valve sizes 6"-12", and associated Washers (F207). Lift the Gland Follower (F208) up off of the Stud Bolts (F210).
2. Remove the two lower Gland Follower / Yoke Nuts (F206) and associated Washers (F207) from the Stud Bolts (F210).
3. Turn the remaining part of the Handwheel (F202) in the closing direction. This will lift the Yoke (F205) up the Stud Bolts until the upper half of the Stem Nut (F201) comes off of the Stem Assembly (F215).
4. Remove the upper half of the Stem Nut (F201) from the handwheel and place it in the "new Handwheel" (F202).

**NOTE:** The Stem Nut pair are keyed with different sized lugs. Be sure to align the lugs in the correct location! (See Fig. 6B)

**CAUTION:** Do not over tighten the upper pair of Gland Follower / Yoke Nuts (F206). Over tightening can cause the Gland (F209) to fracture. Tighten the nuts evenly so the Gland Follower applies even and level pressure on the Gland. If the Gland Follower is assembled at an angle, leaks may occur.

5. Perform steps 1 through 4 in reverse order to re-assemble. Turn the Handwheel a few additional turns after the Yoke has seated on the Bonnet (F217). This will help prevent undue strain placed on the Gland (F209) when replacing the upper nuts and washers.
6. Repressurize the system. At this time, if there is a leak around the Gland (F209) be sure that the upper Gland Follower / Yoke Nuts (F206) are screwed down evenly on the Stud Bolts (F210). Tighten the nuts 1/4 turn each until the leak stops.

**NOTE:** Since UL , ULC and FM Approvals are for the Manufacturer, this procedure will have no effect on listings or approvals.

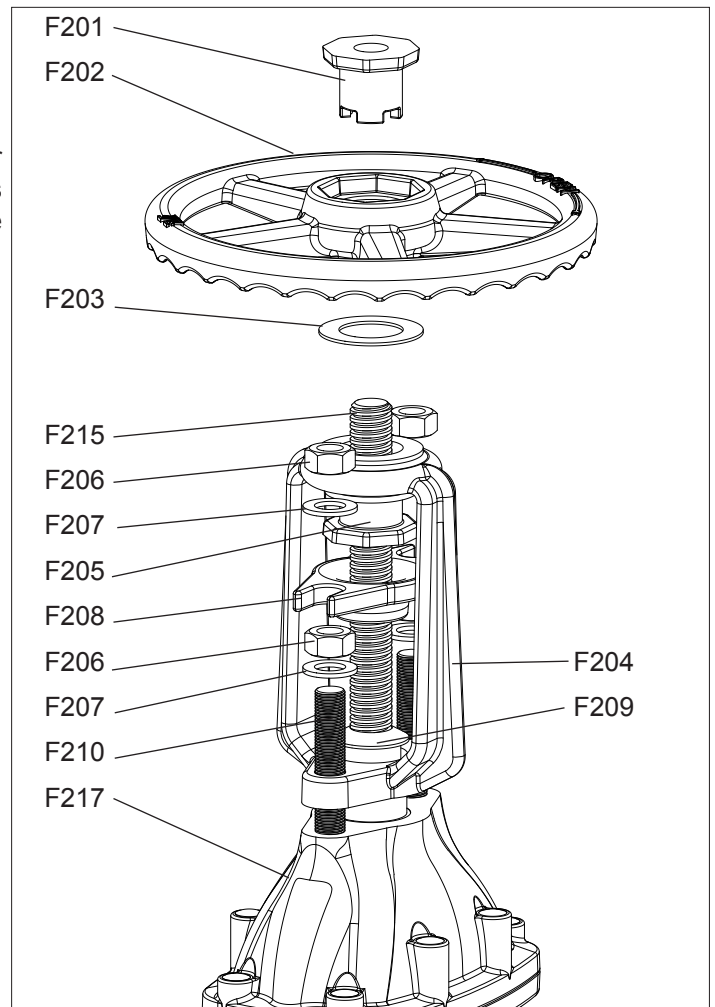

Fig. 6A

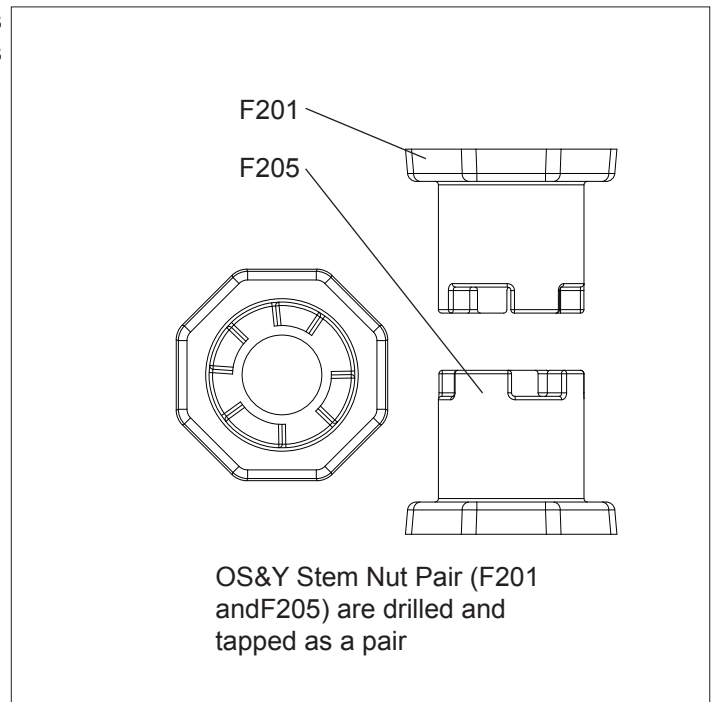

Fig. 6B

## OS&Y (Outside Stem & Yoke) VALVE REPAIRS:

### STEM SEAL O-RING REPLACEMENT (Figs.7A,7B)

**WARNING:** To perform the following steps, be sure the Water Main Supply Line has been shut off, and that the pressure has been bled off! Also provide sufficient clearing around the valve so that no soil or debris may fall into it.

**NOTE:** As most OS&Y valves are used in fire protection applications, verify that any alarm systems have been disabled prior to performing any maintenance or repairs.

1. Remove the two upper Gland Follower / Yoke Nuts (F206) and associated Washers (F207). Lift the Gland Follower (F208) up off of the Stud Bolts (F210). (See Fig. 7A)
2. Lift the Gland (F209) to access the three Stem Seal O-rings (F211).

**NOTE:** These O-rings are split-type o-rings. When replacing them, insure that the splits DO NOT align. Rotate the splits at approximately 30 degree intervals. (See Fig. 7B)

3. Reverse steps 2 and 3 for re-assembly.

**CAUTION:** Do not over tighten the upper pair of Gland Follower / Yoke Nuts (F206). Over tightening can cause the Gland (F209) to fracture. Tighten the nuts evenly so the Gland Follower applies even and level pressure on the Gland. If the Gland Follower is assembled at an angle, leaks may occur.

4. Re-pressurize the system. At this time, if there is a leak around the Gland (F209) be sure that the upper Gland Follower / Yoke Nuts (F206) are screwed down evenly on the Stud Bolts (F210). Tighten the nuts 1/4 turn each until the leak stops.

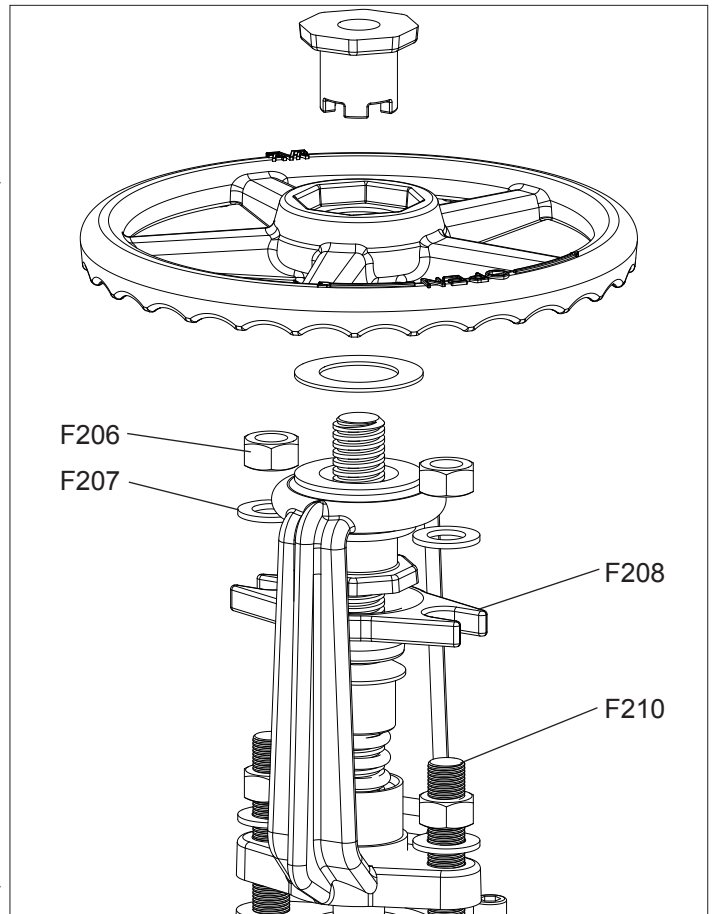

Fig. 7A

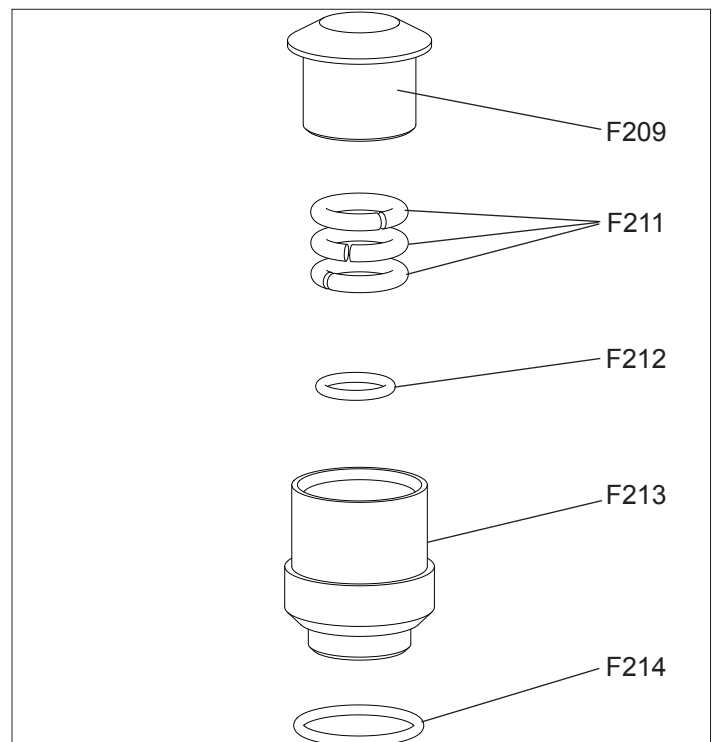

Fig. 7B



## OS&Y (Outside Stem & Yoke) VALVE REPAIRS:

### STEM/WEDGE ASSEMBLY REPLACEMENT (Figs.8A,8B)

**WARNING:** To perform the following steps, be sure the Water Main Supply Line has been shut off, and that the pressure has been bled off! Also provide sufficient clearing around the valve so that no soil or debris may fall into it.

**NOTE:** As most OS&Y valves are used in fire protection applications, verify that any alarm systems have been disabled prior to performing any maintenance or repairs.

1. Remove the two upper Gland Follower / Yoke Nuts (F206), using a 15/16" or 24mm wrench for valve sizes 2.5"-4", or a 1 1/4" or 30mm wrench for valve sizes 6"-12", and associated Washers (F207). Lift the Gland Follower (F208) up off of the Stud Bolts (F210).
2. Remove the two lower Gland Follower / Yoke Nuts (F206) and associated Washers (F207) from the Stud Bolts (F210).
3. Turn the remaining part of the Handwheel (F202) in the closing direction. This will lift the Yoke (F205) up the Stud Bolts until the upper half of the Stem Nut (F201) comes off of the Stem Assembly (F215).
4. Remove the upper half of the Stem Nut (F201) from the handwheel and place it in the "new Handwheel" (F202).

**NOTE:** The Stem Nut pair are keyed with different sized lugs. Be sure to align the lugs in the correct location!  
(See Fig. 6B)

5. Line up the new Handwheel and upper half of the Stem Nut (F201), with the correct slots on the lower half of the Stem Nut (F205). Carefully turn the Handwheel and Stem Nut to begin threading them onto the Stem (F215).
6. Turn the Handwheel a few additional turns after the Yoke has seated on the Bonnet (F217). This will help prevent undue strain placed on the Gland (F209) when replacing the upper nuts and washers.

**CAUTION:** Do not over tighten the upper pair of Gland Follower / Yoke Nuts (F206). Over tightening can cause the Gland (F209) to fracture. Tighten the nuts evenly so the Gland Follower applies even and level pressure on the Gland. If the Gland Follower is assembled at an angle, leaks may occur.

6. Replace the two lower Gland Follower / Yoke Nuts (F206) and associated Washers (F207), Gland Follower (F208), and upper washers and nuts.
7. Repressurize the system. At this time, if there is a leak around the Gland (F209) be sure that the upper Gland Follower / Yoke Nuts (F206) are screwed down evenly on the Stud Bolts (F210). Tighten the nuts 1/4 turn each until the leak stops.

**NOTE:** Since UL , ULC and FM Approvals are for the Manufacturer, this procedure will have no effect on listings or approvals.

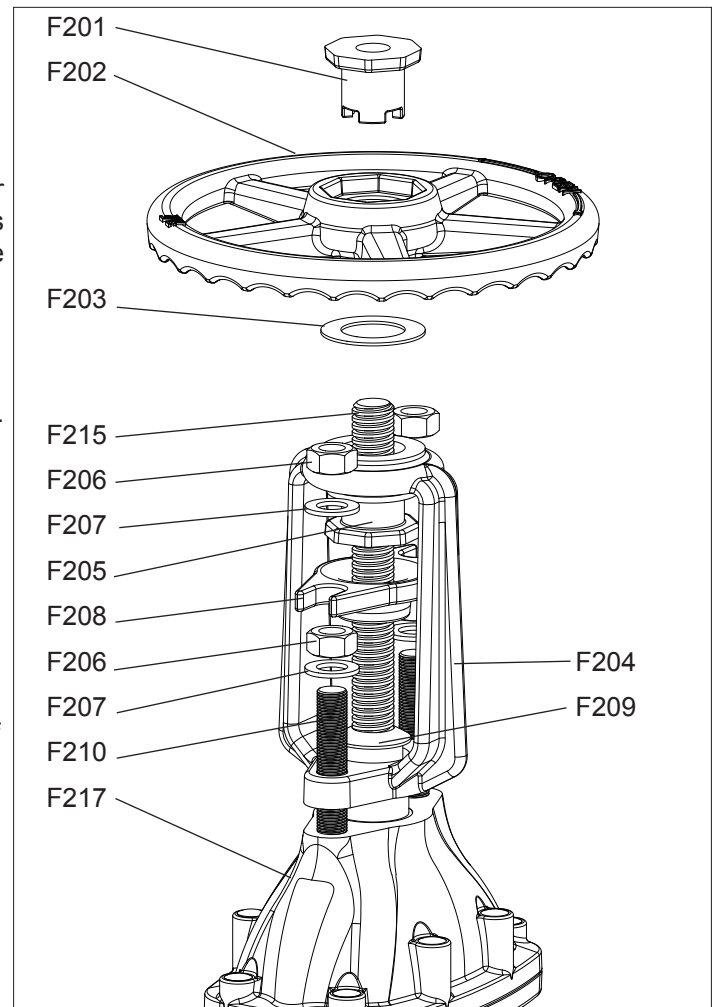

Fig. 8A

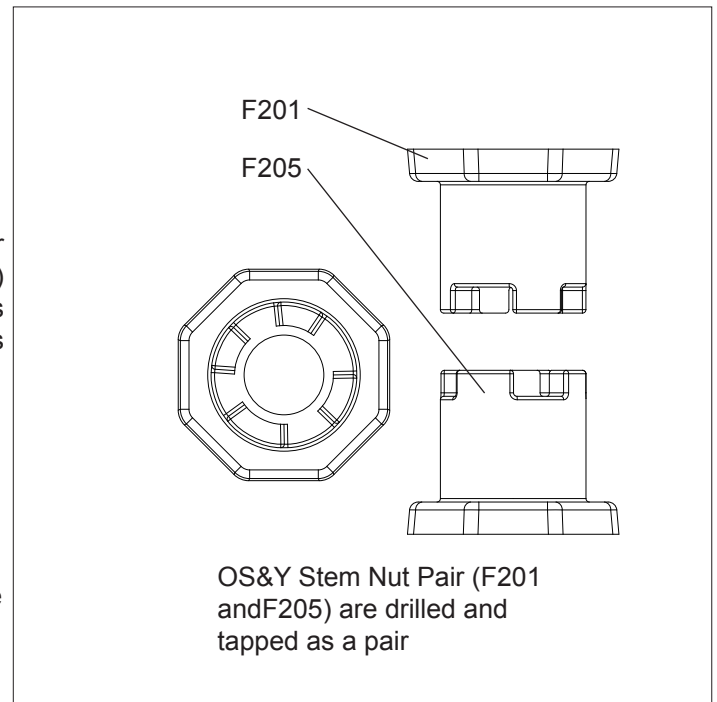

Fig. 8B

**OPTIONAL EQUIPMENT:**

**ACTUATOR ADAPTERS: (Figs. 9A,9B)**

American AVK Company offers gear adapters for both NRS and OS&Y valves. Gear adapters for NRS valves are available in sizes 2.5" through 24".

OS&Y valves are available in sizes 2.5" through 12". Flange sizes are listed in "Table 1".

Table 1

2.5"	3"	4"	6"	8"	10"	12"	14"	16"	18"	20"	24"
FA10	FA10	FA10	FA10	FA10	FA14	FA14	FA14	FA14	FA16	FA16	FA16

Fig. 9A lists the parts that differ from standard valves.

- F245 Gland Bolts (Adapter Plate)
- F246 Actuator Adapter Gland
- F247 Stem Key
- F248 Actuator Stem

Fig. 9B shows an OS&Y Adaptor Yoke (F249). Note that when an OS&Y Adaptor Yoke is configured, the OS&Y Handwheel, Stem Nut pair, and Anti Friction Washer are not used.

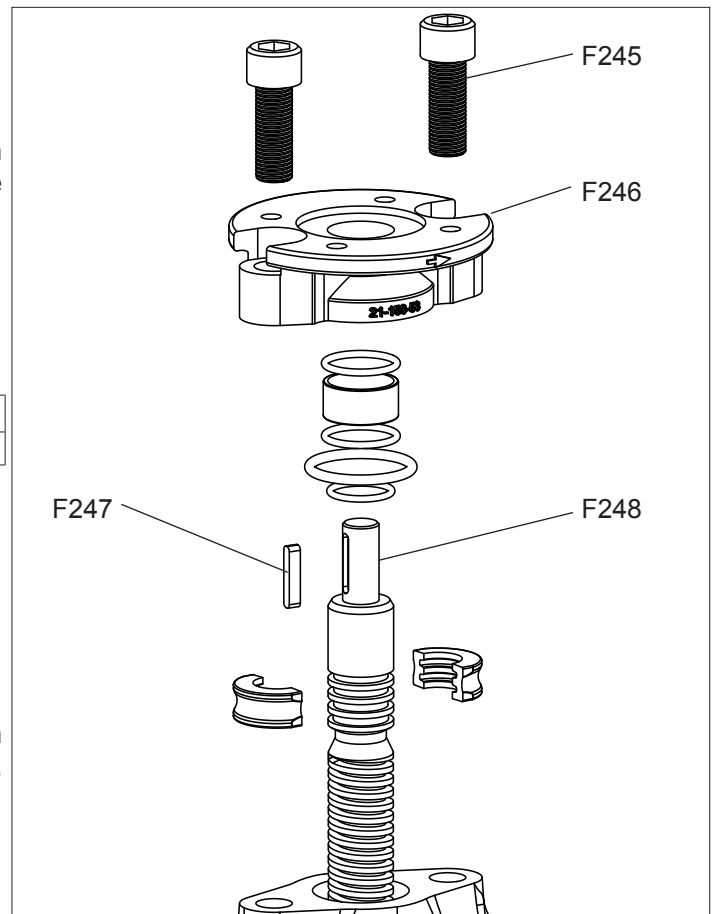

Fig. 9A

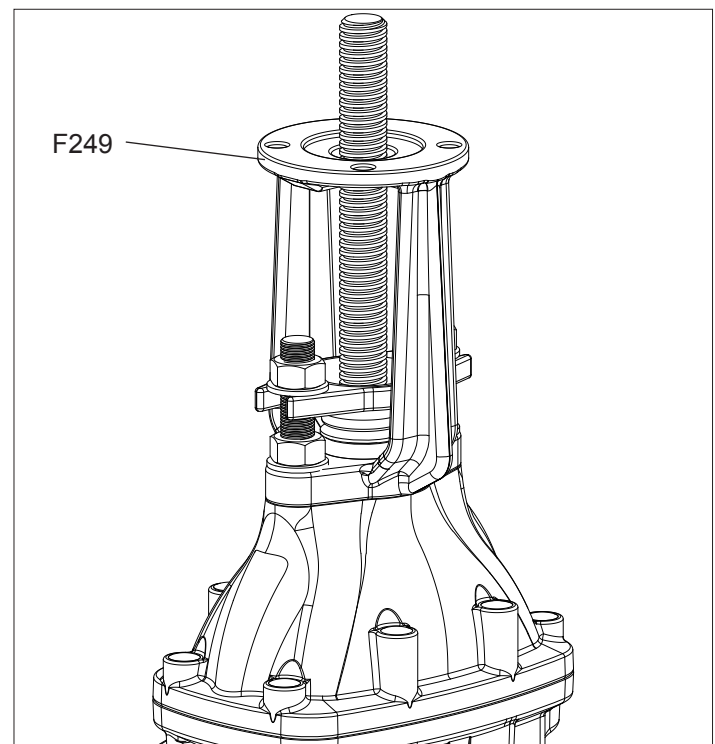

Fig. 9B

## OPTIONAL EQUIPMENT:

### POST INDICATOR PLATES: (Figs. 10)

NRS valves are available with Post Indicator Plates in valve sizes 4" through 16". The valves can be ordered from the factory pre-configured, or can be re-configured in the field.

**CAUTION:** With the valve in the fully "OPEN" position, the following procedures can be performed under full working pressure, with no need to shut down the system.

1. Remove the Wrench Nut/ Handwheel Bolt (F220) and Wrench Nut/Handwheel Washer (F221) using a 1/2", (13mm) wrench, for 2 1/2" to 4" valve sizes, and 11/16", (17mm) wrench for 6" to 12" valve sizes. Remove the Wrench Nut (F225).
2. Remove the two Gland Flange Bolts (F227) using a 15/16" or 24mm wrench for valve sizes 2.5"-4", or a 1 1/4" or 30mm wrench for valve sizes 6"-12".
3. Remove the Gland Flange (F228) with Wiper Ring (F226) attached.

**NOTE:** The Wiper Ring (F226) is a "Factory Installed" press fit and therefore must be reordered as an assembly along with the Post Indicator Plate (F224).

4. Take the Upper Stem Seal O-rings, quantity 2, (F230) and the Stem Seal Bushing (F231) from the old assembly and install them into the Post Indicator Plate. Lightly grease the o-rings with a food grade grease that contains no acetate or silicone.
5. Install the Gland O-ring (F229) into the groove in the bottom of the Post Indicator Plate and carefully slide the assembly over the Stem, onto the valve bonnet. Secure with the new Post Indicator Plate Bolts (F223).

**NOTE:** The Post Indicator Plate Bolts are longer than the Gland Flange Bolts.

6. Replace the Wrench Nut and secure it with the Wrench Nut Bolt and Washer.

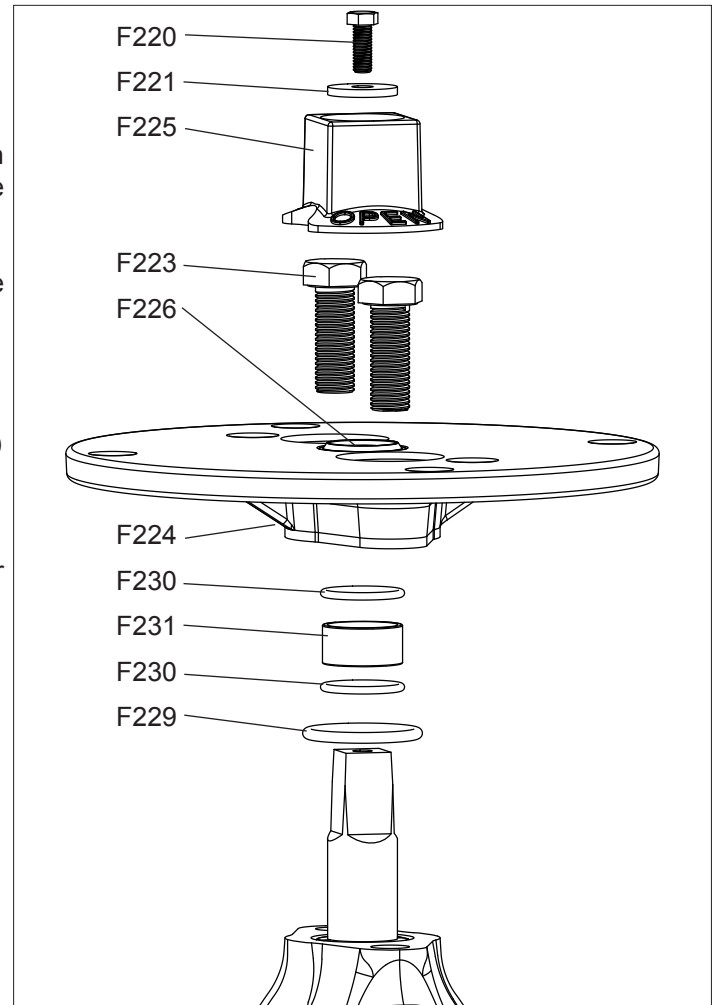

Fig. 10

## OPTIONAL EQUIPMENT:

### BYPASS ASSEMBLIES: (Fig. 11)

American AVK offers bypass assemblies for series 55 valves in sizes 18" through 24". These assemblies can be bolted to Flanged by Flanged valves. The Spool Pieces (F250), are available in Flanged by Flanged (FLxFL) or Flanged by Mechanical Joint (FLxMJ) configurations. This allows valve bypass configurations in FLxFL, FLxMJ, or MJxMJ.

18" and 20" valves have 3" bypass valve Elbows (F251).  
24" valves have 4" Elbows.

Bypass valves can be configured for both horizontal and vertical valve positions.

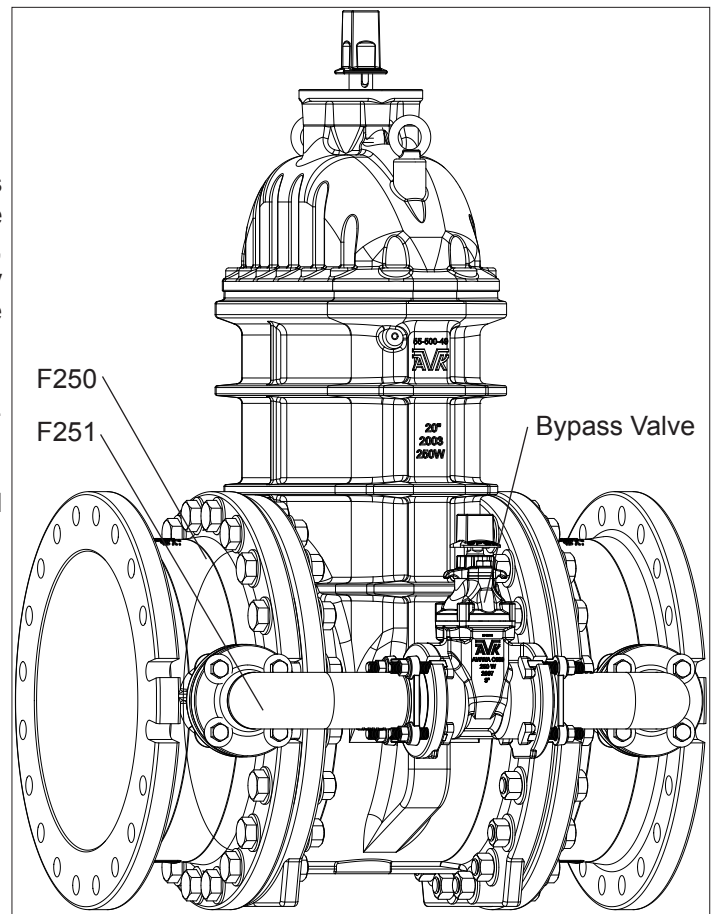

Fig. 11

## TROUBLESHOOTING GUIDE

**WARNING:** The valve must be isolated before performing any maintenance. Failure to do so may cause pressure to be released resulting in severe injury or death.

Several problems and solutions are presented below to assist you in troubleshooting the hydrant.

**PROBLEM: Valve leaking around stem/ gland flange.**

Probable Cause: Damaged or worn o-rings.

Corrective action: Refer to the UPPER and LOWER STEM SEAL COMPONENT REPAIR sections of this manual and replace the o-rings

**PROBLEM: Valve leaking around Bonnet and Body.**

Probable Cause: Bonnet Bolts loose.

Corrective action: Tighten Bonnet Bolts.

Probable Cause: Damaged Bonnet Gasket.

Corrective action: Replace Bonnet Gasket

**PROBLEM: Valve leaking around pipe connections.**

Corrective action: Tighten flange hardware.

Corrective action: Verify gasket is not damaged. Replace if necessary.

**PROBLEM: Valve hard to operate.**

Probable Cause: Gland Bolts too tight or tightened unevenly.

Corrective action: Loosen then re-tighten Gland Bolts evenly.

Probable Cause: If the valve has not been operated over a prolonged period of time, build-up may occur on the internal parts.

Corrective Action: Open or close the valve one turn at a time until fully opened or closed. Repeat the process a few times then flush the system to remove any debris.

Probable Cause: Pressure build-up in system.

Corrective Action: Relieve pressure and bleed off any air build-up.

## **PARTS AND SERVICE**

For information on parts and service for your area contact American AVK. Make a note of the valve model number and size located on the valve and contact:

**American AVK Company**

2155 N. Meridian Blvd.

Minden, NV 89423

PH: 775-552-1400

FAX: 775-783-1031

[www.americanavk.com](http://www.americanavk.com)

**AMERICAN AVK COMPANY TEN (10) YEAR WARRANTY  
RESILIENT WEDGE GATE VALVES**

American AVK Company warrants its Series 03, Series 18, Series 25, Series 45, Series 55, Series 65 and Series 66 Resilient Wedge Gate Valves to be free from defects in workmanship and materials for a period of ten (10) years from the date of shipment from American AVK Company. American AVK Company shall have no obligation under this warranty unless it is notified of claims hereunder promptly and in writing upon discovery thereof and within the warranty period, and unless the product is delivered to the American AVK Company facility within thirty (30) days of such notice.

American AVK shall have the right to inspect said product before it is removed from installation. If the product is removed from installation prior to approval from American AVK this warranty shall be void.

As to motors, gearing or accessory equipment purchased by American AVK Company from others manufacturers, and used or incorporated into American AVK Company's products, those manufacturers' warranties shall apply.

American AVK Company will honor all reasonable costs to repair or replace any American AVK Company Resilient Wedge Gate Valve found to be defective.

American AVK Company's sole responsibility shall be, in its sole discretion, to replace the product with the same or a similar product, repair the product, or refund the price paid for the product provided the product has been properly applied and used under normal service and under conditions for which it is designed. American AVK Company shall not be liable for indirect, special, incidental, or consequential damage or penalties and does not assume any liability of purchase to others or to anyone for injury to persons or property.

**THIS IS THE EXCLUSIVE WARRANTY GIVEN IN CONNECTION WITH THE SALE OF THIS PRODUCT. THERE ARE NO OTHER WARRANTIES, EXPRESSED OR IMPLIED, INCLUDING EXPRESSED OR IMPLIED WARRANTY OF MERCHANTABILITY, OR ANY EXPRESSED OR IMPLIED WARRANTY OF SUITABILITY FOR ANY PARTICULAR PURPOSE, GIVEN BY AMERICAN AVK COMPANY IN CONNECTION WITH THIS PRODUCT.**

