

Future-Proof Your AMI Data Collection

Neptune® R900® System: LoRaWAN® Gateway



Easily integrated into the Neptune R900® System, the LoRaWAN® gateway helps you to get the most value from your LoRaWAN endpoint infrastructure and allows you to migrate at your own pace from a walk-by or mobile Automatic Meter Reading (AMR) to an Advanced Metering Infrastructure (AMI).

The LoRaWAN® gateway allows you to quickly deploy your own LoRaWAN-based AMI Network that provides robust fixed network meter reading with the capability to support additional LoRaWAN Smart Water applications. LoRa's adaptive data rate (ADR) technology optimizes data rates, connectivity, and capacity of the network, providing a scalable AMI and Smart Water solution. Easily collect critical metering data to improve operations and customer support and optimize distribution system management.

- Deploy a LoRaWAN network with ease
- Reduce infrastructure with longer range LoRa® transmissions
- Ensure end-to-end security and confidentiality with 128-Bit AES encryption
- Eliminate the hassle associated with programming gateways and endpoints

Specifications

LoRa® Radio Parameters

- 902 - 915 MHz (Rx)
- 923 - 928 MHz (Tx)
- 72 channels
- 1W (Tx Power)

Installation Options

- Rooftop
- Pole 2" - 16" diameter (5cm - 40cm)
- Wall
- Water towers
- Street lights

Power Supplies

- 100 - 140 VAC
- Solar

Battery Backup

- UPS provides up to 18 hours of battery backup

Backhaul Options

- Multi-Carrier 4G LTE cellular modem
- Ethernet

Environmental

- IP67 enclosure
- Operating temperature: -40°F to +131°F (-40°C to +55°C)
- 10 - 100% condensing operational humidity
- Weight 11 lbs (5 Kg)

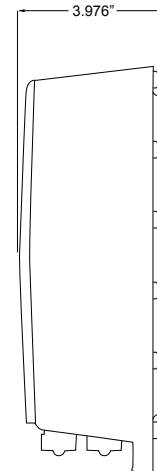
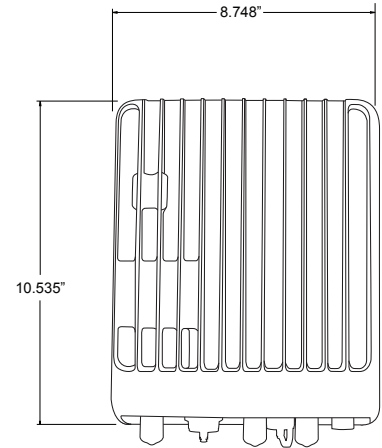

Ti SALES

36 Hudson Rd
Sudbury, MA 01776

800.225.4616
www.tisales.com



Metering Systems Support
978.261.7683