



MACH 10[®] Residential Ultrasonic Meter Installation and Maintenance Guide



MACH 10[®] Residential Ultrasonic Meter
Installation and Maintenance Guide

Proprietary Rights Notice

This manual is an unpublished work and contains the trade secrets and confidential information of Neptune Technology Group Inc., which are not to be divulged to third parties and may not be reproduced or transmitted in whole or part, in any form or by any means, electronic or mechanical for any purpose, without the express written permission of Neptune Technology Group Inc. All rights to design or inventions disclosed herein, including the right to manufacture, are reserved to Neptune Technology Group Inc.

Neptune engages in ongoing research and development to improve and enhance its products. Therefore, Neptune reserves the right to change product or system specifications **without** notice.

Trademarks Used in This Manual

MACH 10[®] and E-CODER[®] are registered trademarks of Neptune Technology Group Inc. MACH 10[®])R900i[™], and ProRead[™] are trademarks of Neptune Technology Group Inc. Other brands or product names are the trademarks or registered trademarks of their respective holders.

FCC Notice

This device complies with Part 15 of the FCC Rules. Operation is subject to the following two conditions:

- This device may not cause harmful interference.
- This device must accept any interference received, including interference that may cause undesired operation.

Note: This equipment has been tested and found to comply with the limits for a Class B digital device, pursuant to Part 15 of the FCC Rules. These limits are designed to provide reasonable protection against harmful interference in a residential installation. This equipment generates, uses, and can radiate radio frequency energy, and if not installed and used in accordance with the instructions, may cause harmful interference to radio communications. However, there is no guarantee that interference will not occur in a particular installation. If this equipment does cause harmful interference to radio or television reception, which can be determined by turning the equipment off and on, the user is encouraged to try to correct the interference by one or more of the following measures:

- Reorient or relocate the receiving antenna.
- Increase the separation between the equipment and receiver.
- Connect the equipment to an outlet on a circuit different from that to which the receiver is connected.
- Consult the dealer or an experienced radio / TV technician for help.



Caution! Changes or modifications not expressly approved by the party responsible for compliance could void the users' authority to operate the equipment.

Professional Installation

In accordance with section 15.203 of the FCC rules and regulations, the Neptune endpoint must be professionally installed by trained installers. Changes or modifications not expressly approved by the party responsible for compliance void the user's authority to operate the equipment.

Industry Canada

This Class B digital apparatus meets all requirements of the Canadian Interference Causing Equipment Regulations. Operation is subject to the following two conditions:

- This device may not cause harmful interference.
- This device must accept any interference received, including interference that may cause undesired operation.

Cet appareillage numérique de la classe B répond à toutes les exigences de l'interférence canadienne causant des règlements d'équipement. L'opération est sujette aux deux conditions suivantes: (1) ce dispositif peut ne pas causer l'interférence nocive, et (2) ce dispositif doit accepter n'importe quelle interférence reçue, y compris l'interférence qui peut causer l'opération peu désirée.

*MACH 10[®] Residential Ultrasonic Meter
Installation and Maintenance Guide*
Literature No. IM MACH 10 03.2024

Neptune Technology Group Inc.
1600 Alabama Highway 229
Tallahassee, AL 36078
Tel: (800) 633-8754
Fax: (334) 283-7293

Copyright © 2003-2024
Neptune Technology Group Inc.
All Rights Reserved.

Chapter 1: Product Description	1
Introduction	1
Understanding Ultrasonic Technology	1
Transit-Time Technology	2
Product Overview	2
Summary	3
Chapter 2: MACH 10® Specifications	5
Environmental and Performance Specifications	5
Weight and Dimension Specifications	5
Dimensions	6
Additional Specifications	7
Fluid Compatibility	8
Maincase	8
Transducers	8
Battery Requirement	8
Chapter 3: Installing the MACH 10® Ultrasonic Meter	9
Tools and Materials	9
Storage	9
Unpacking	10
Safety and Preliminary Checks	10
Installation and Application Considerations	10
Water Temperature	10
Meter Installation	10
Water Flow	11
Meter Sizing and Selection	11
Installation Instructions for MACH 10® Meters	12
Installing a New Meter	12

Wiring the MACH 10®	13
Completing the Wiring	15
Chapter 4: Operating the MACH 10® Ultrasonic Meter	19
LCD Meter Display	19
Timeout Period	19
Meter Display	19
LCD Panel	20
How to Read the Meter	20
Flags	20
LCD Icons	21
Consumption and Unit of Measure	22
Rate of Flow	23
Flow Direction	23
Temperature	24
Pressure	24
AMR / AMI Output	24
Endpoint Reading Resolution	24
Bench Testing the Meter	24
Chapter 5: Maintenance and Troubleshooting	25
Maintenance	25
Replacement Parts	25
General Troubleshooting	25
Checklist	26
Contact Information	27
By Phone	27
By Email	27

<i>Appendix A: MACH 10®)R900i™</i>	29
Product Description	29
MACH 10®)R900i™ Programming	30
MACH 10®)R900i™ Specifications	30
Electrical Specification	30
Transmitter Specifications	31
Environmental Conditions	31
Functional Specifications	32
Dimensions	32
Flags	34
<i>Glossary</i>	37
<i>Index</i>	41

This page intentionally left blank.

Figure 1 – MACH 10® Residential Ultrasonic Meter - Open View	2
Figure 2 – MACH 10® Residential Ultrasonic Meter - Closed View	3
Figure 3 – Residential Meter Dimensions – Top View	6
Figure 4 – Residential Meter Dimensions – Side View	7
Figure 5 – MACH 10® Meter with Arrows Showing Flow Direction	11
Figure 6 – Scotchlok™ Connector	13
Figure 7 – Seat the Connector Wires	14
Figure 8 – Crimping Tool	14
Figure 9 – Three Colored Wires Connected	15
Figure 10 – Splice Tube	16
Figure 11 – Gray Wires in Slot	16
Figure 12 – Cover in Place	17
Figure 13 – MACH 10® LCD Display and Light Sensor	19
Figure 14 – MACH 10® LCD Panel	20
Figure 15 – MACH® 10™ Integrated Meter.....	30
Figure 16 – MACH 10®)R900i™ – Top View.....	32
Figure 17 – MACH 10®)R900i™ – Side View.....	33
Figure 18 – MACH 10®)R900i™ – Front View	33

This page intentionally left blank.

Table 1 – Environmental Specifications	5
Table 2 – Performance Specifications	5
Table 3 – MACH 10® Meter Weight Specifications	6
Table 4 – Residential MACH 10® Dimensions in Inches	6
Table 5 – Additional Specifications	8
Table 6 – Recommended Tools and Materials for Meter Installation	9
Table 7 – Performance Specifications	12
Table 8 – Color Codes for Wires	15
Table 9 – MACH 10® Icons and Displays	22
Table 10 – Consumption and Units of Measure	22
Table 11 – Available Units of Measure	23
Table 12 – Errors When LCD Does Not Display	25
Table 13 – Errors When Flow Icons are Displayed	26
Table 14 – Transmitter Specifications	31
Table 15 – Environmental Conditions	31
Table 16 – Functional Specifications	32
Table 17 – Residential MACH 10®)R900i™ Dimensions in Inches	34
Table 18 – Eighth Digit Resolution by Meter Size	34
Table 19 – MACH 10®)R900i™ Flags (digits)	34
Table 20 – Continuous Flow Flags	35

This page intentionally left blank.

This chapter provides a general description of the Neptune® MACH 10® Ultrasonic Meter (MACH 10).

Introduction

The MACH 10 solid state meter uses ultrasonic transit-time technology and solid state electronics. The meter is contained in a compact, totally encapsulated, weatherproof, and ultraviolet (UV) resistant housing for residential and light commercial applications. Ultrasonic technology features the following:

- Contains no moving parts.
- Provides accuracy for the life of the meter.
- Reduces measurement errors due to sand, suspended particles, and pressure fluctuations.

The MACH 10 supports Neptune's R900® and other Automatic (or automated) Meter Reading (AMR) or Advanced Metering Infrastructure (AMI) endpoints.

The MACH 10®)R900i™ contains a MACH 10 meter and an integrated R900 radio for transmitting meter reading data.

The meter electronics and battery are fully IP-68 rated to eliminate the intrusion of moisture, dirt, or other contaminants. It is suitable for installation in all environments including meter pits subject to continuous flooding.

Understanding Ultrasonic Technology

An ultrasonic water meter uses high-frequency sound waves to measure the velocity of an acoustically-conductive fluid moving through it. The velocity of the fluid is then converted to volume throughput using sophisticated algorithms and electronics.

An ultrasonic water meter uses high-frequency sound waves to measure the velocity of an acoustically-conductive fluid moving through it. The velocity of the fluid is then converted to volume throughput using sophisticated algorithms and electronics.

Transit-Time Technology

The MACH 10 utilizes *transit-time* ultrasonic technology. This technology takes advantage of the principle that an acoustic signal travels faster with the flow than against the flow of the fluid. These meters use transducers that are essentially transceivers, sending and receiving the acoustic signals.

The difference between the downstream and upstream transit time—the time it takes for the signal to travel from one transducer to the other—is proportional to the flow rate.

The calculated velocity of the water is then converted to volume based on the area of the measurement section and by the algorithms and electronics in the register.

Product Overview

The following images show the components of the MACH 10 meter.



* Pressure indicator appears only on pressure-capable meters

Figure 1 – MACH 10[®] Residential Ultrasonic Meter - Open View

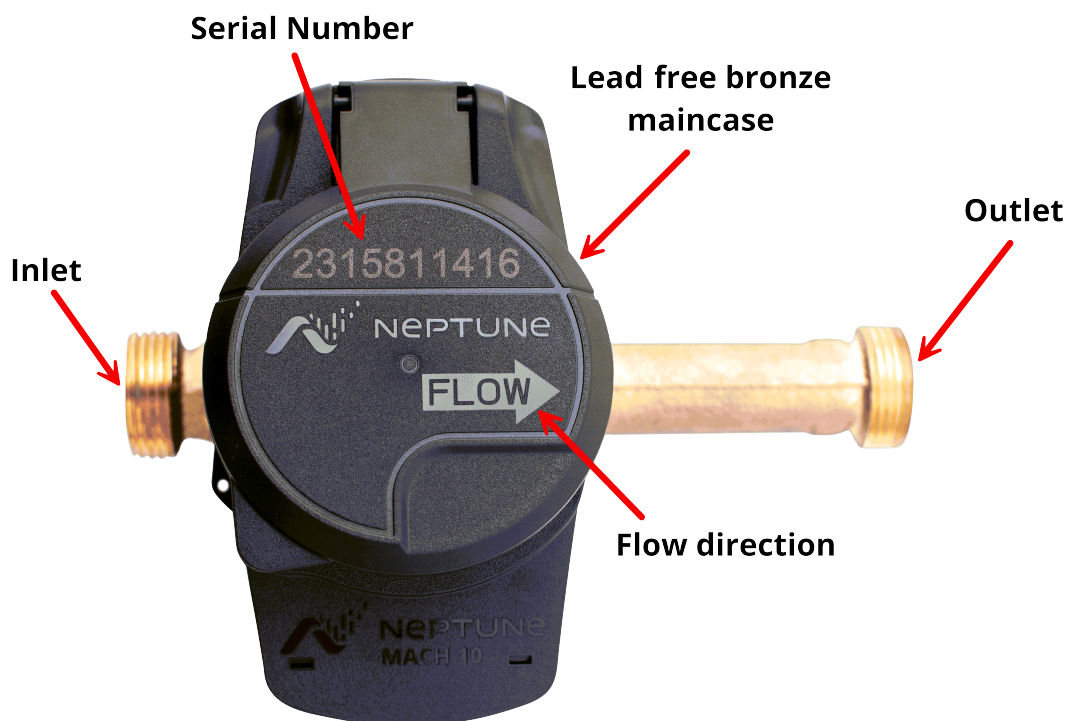

Figure 2 – MACH 10[®] Residential Ultrasonic Meter - Closed View

Summary

The MACH 10 meter is a transit-time ultrasonic flow meter with wetted transducers. Designed as an alternative for mechanical meters, the MACH 10 meter utilizes traditional utility pipe connectors and lay lengths. It is totally self-contained. The battery, processor circuit, and electronic display are fully potted and permanently sealed as an integral unit.

The MACH 10 meter supports the Neptune R900[®] and other AMR / AMI endpoints. The MACH 10[®])R900™ contains a MACH 10 meter and an integrated R900 radio for transmitting meter reading data.

This page intentionally left blank.

Chapter 2: MACH 10[®] Specifications

This chapter provides the specifications for the MACH 10[®] Ultrasonic Meter.

Environmental and Performance Specifications

This table defines environmental specifications that apply to the residential MACH 10. The MACH 10 meets AWWA C-715 accuracy specifications for water temperatures from 33° to 122° F (+0.5 C to 50° C).

Table 1 – Environmental Specifications

Specification	Description
Operating temperature	14° to 149° F (-10° to 65° C).
Storage temperature	-40° to 158° F (-40° to 70° C).
Water temperature	33° to 122° F (+0.5° to 50° C).
Operating humidity	0 to 100% condensing.

This table defines performance specifications that apply to residential MACH 10 meters.

Table 2 – Performance Specifications

Meter Size	Normal Operating Range @ 100% Accuracy (± 1.5%)	AWWA C715 Standard Type 1	Extended Low Flow @ 100% Accuracy (± 3%)
5/8 inch	0.10 to 25 U.S. gpm	0.2 to 20 U.S. gpm	0.05 U.S. gpm
3/4 inch	0.10 to 35 U.S. gpm	0.5 to 30 U.S. gpm	0.05 U.S. gpm
1 inch	0.40 to 55 U.S. gpm	0.75 to 50 U.S. gpm	0.25 U.S. gpm

Weight and Dimension Specifications

The following tables define the weight and dimension specifications for the residential MACH 10 meters.

Table 3 – MACH 10[®] Meter Weight Specifications

Meter Size	Weight
5/8 inch	2.4 lbs
5/8 inch x 3/4 inch	2.5 lbs

Table 3 – MACH 10® Meter Weight Specifications (continued)

Meter Size	Weight
3/4 inch	2.5 lbs
1 inch	3.4 lbs

Dimensions

The table defines the dimensions for the MACH 10 meter in inches.

Table 4 – Residential MACH 10® Dimensions in Inches

Meter Size	A	B	D	E	F	G	ID
5/8 x 5/8 inch	7.50	5.71	5/8 thread	2.86	4.93	3.00	ø .69
5/8 inch x 3/4 inch	7.50	5.71	3/4 thread	2.86	4.93	3.00	ø .69
3/4 x 3/4 inch	9.00	5.71	3/4 thread	2.90	5.75	3.00	ø .83
3/4 inch SL	7.50	5.71	3/4 thread	2.90	5.00	3.00	ø .83
3/4 inch x 1 inch	9.00	5.71	1 inch thread	2.90	5.75	3.00	ø .83
1 x 1 inch	10.75	5.71	1 inch thread	3.04	7.09	3.00	ø .1.05
1 inch x 1-1/4 inch	10.75	5.71	1-1¼ thread	3.04	7.09	3.00	ø .1.05

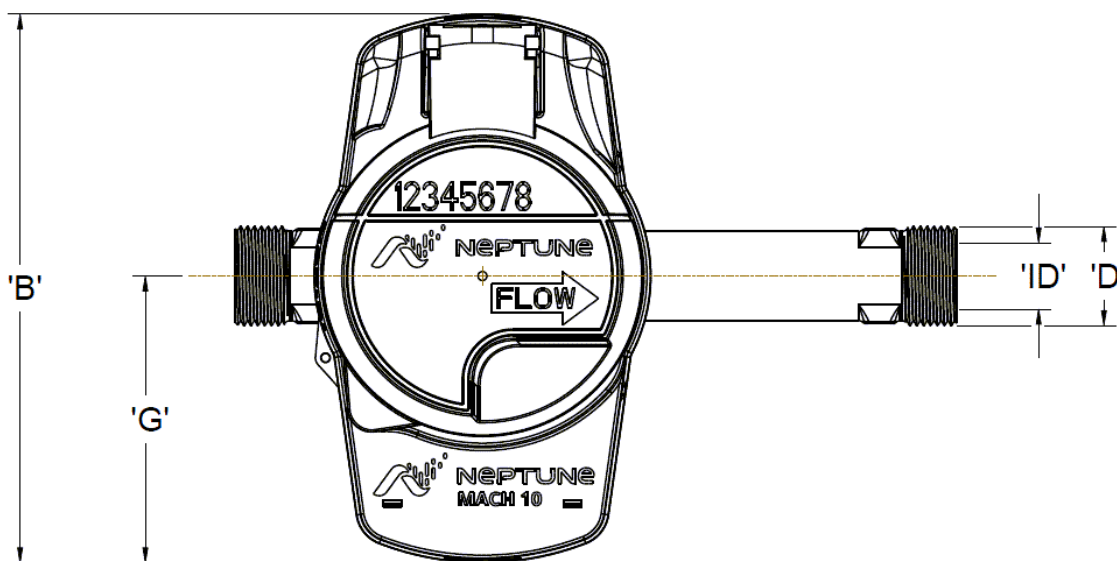

Figure 3 – Residential Meter Dimensions – Top View

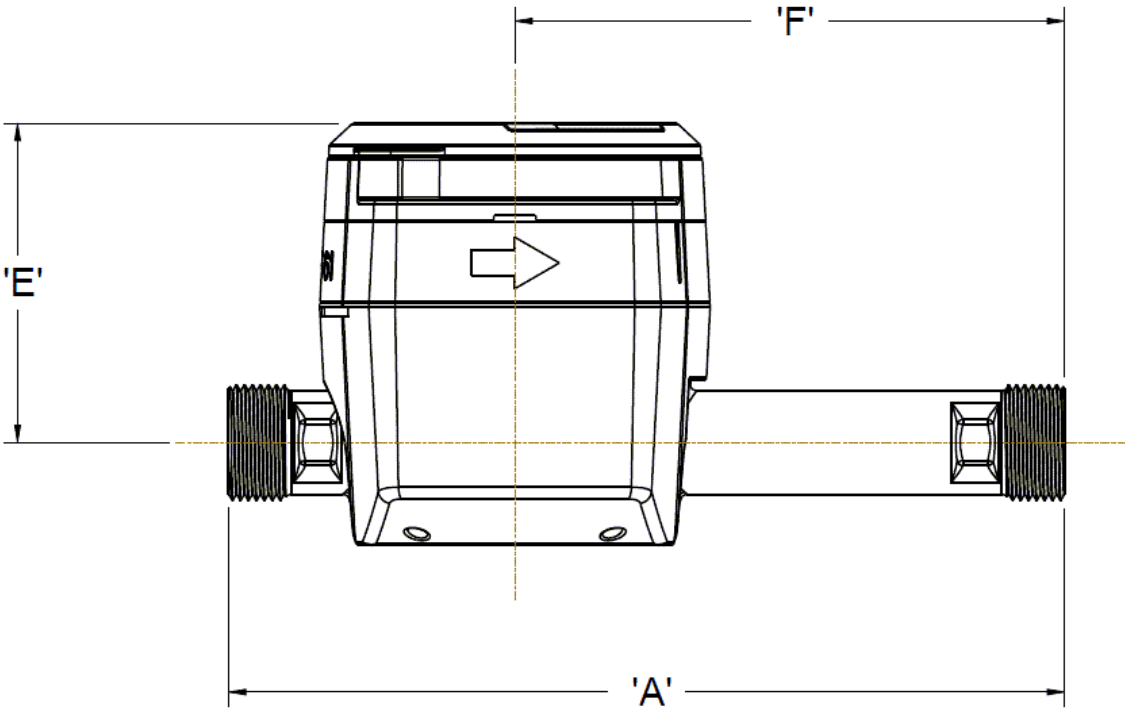

Figure 4 – Residential Meter Dimensions – Side View

Additional Specifications

The following specifications are for the 5/8-inch through 1-inch residential meters.

Table 5 – Additional Specifications

Specification	Description
Maximum Operating Pressure	175 psig.
Fire Service Maximum Operating Pressure	175 psig.
Register Type	Straight reading, permanently sealed electronic Liquid Crystal Display (LCD); digits are 0.28" (7 mm) high.
Register Display	<ul style="list-style-type: none"> • Consumption (up to nine digits). • Rate of flow. • Flags. • Unit of measure factory programmed for gallons, cubic feet, or cubic metres.
Battery	3.6 volt lithium thionyl-chloride; battery is fully encapsulated within the register housing.

Table 5 – Additional Specifications (continued)

Specification	Description
Optional Pressure Sensor	<ul style="list-style-type: none">• Maximum operating pressure of 175 psig.• Accuracy +/- 2% of full scale.• Operating temperature of -40 to 158 F (-40 to 70 C).
Temperature	Standard and factory programmed in Fahrenheit or Celsius.

Fluid Compatibility

The MACH 10 meter is designed and calibrated for potable, combination potable and fire service, and reclaimed water across the defined temperature and flow range.

Maincase

The meter maincase is manufactured using lead free bronze and contains the wetted elements of the meter: two transducers, reflectors, and the flow conditioner.

Transducers

The piezoelectric transducer is the heart of the system and have very high measurement dynamics.

The signal path of the transducer utilizes three stainless steel reflectors. The transducers are permanently installed, and the path length and angles are fixed. Each meter is uniquely calibrated at the factory and the calibration data is permanently stored in the meter.

Battery Requirement

Solid state metering technologies require a battery to power the transducers and electronics. The MACH 10 uses a 3.6 volt lithium thionyl- chloride battery.

Chapter 3: Installing the MACH 10[®] Ultrasonic Meter

All MACH 10[®] ultrasonic meters are delivered activated and ready to be installed. When the meter lid is opened, the meter shows the empty pipe icon and the latest volume on the LCD. Consumption is set to zero on each meter before it leaves the factory. The empty pipe icon clears immediately after the meter is installed and the meter measuring pipe is full.

This chapter defines tools, materials, and general installation instructions for the MACH 10[®].

Tools and Materials

The following tables show the recommended tools and materials you need to successfully install the MACH 10.



Important! The tables in this chapter may not contain complete lists of tools and materials.

Table 6 – Recommended Tools and Materials for Meter Installation

Item	Description / Recommendation	Use
Site Work Order	Documentation provided by your utility.	Receiving and recording information about the work site.
Tool Kit	Contains standard tools including: <ul style="list-style-type: none">• Screwdrivers.• Pliers.• Wrench.	Performing various installation procedures.
Flashlight	N/A	Activating the LCD.
Moisture Protection Compound	Novagard [®] sealant Part No: 96018-072.	Connecting the pit antenna to the endpoint (if required).
Magnet	<ul style="list-style-type: none">• 6 lb force.• Part No: 12287-0001.	Activating the endpoint (if required).
UR Crimping Tool	Spring-loaded action Scotchlok crimping pliers.	Wiring meter and endpoint together via Scotchlok connectors.

Storage

Upon receipt, inspect the shipping containers for damage and inspect the contents of any damaged cartons prior to storage. After completing the inspection, store the cartons in a clean, dry environment.

Unpacking

After unpacking the meter, inspect it for damage. If the meter appears to be damaged, notify your Neptune® territory manager or distributor. If a meter requires return shipment, use the original cardboard box and packing material.

Safety and Preliminary Checks

Observe the following safety and preliminary checks before and during each installation:

- Verify that you are at the location specified on the site work order.
- Verify that the site is safe for you and your equipment.
- If applicable, notify the customer of your presence, and tell the customer that you need access to the water meter.
- Record the ID number of the MACH 10 meter you are about to install on the site work order. If the site work order already has a MACH 10 ID number, verify that it matches the ID number on the MACH 10 you are about to install.

Installation and Application Considerations

This section provides information to consider before installing the MACH 10.

Water Temperature

The temperature range of the water is a factor in the selection of an ultrasonic meter, since the meter is calibrated to operate within a specified range. The MACH 10 meter is calibrated for water operating temperature between 33° F and 122° F (or 0.5° C and 50° C) measuring applications.

Meter Installation

Install the MACH 10 meter using horizontal or vertical piping applications. The meter features standard lay lengths for ease of retrofit of mechanical meters. A flow direction arrow is visible on the top and side of the meter to aid in installation in the proper direction.



Figure 5 – MACH 10® Meter with Arrows Showing Flow Direction

Water Flow

The MACH 10 meter is unable to measure flow when an empty pipe condition is detected. An empty pipe is defined as a condition when the ultrasonic sensors are not fully wetted. In this situation, the meter indicates an empty pipe flag and no measurement occurs.

Meter Sizing and Selection

Traditional meter sizing methods apply to both electronic meters and mechanical meters. That is, the maximum flow and maximum continuous flow rate requirements should be considered when selecting a meter. Mechanical meters allow a temporary flow at a rate higher than the maximum continuous flow. However, since the MACH 10 has no moving parts, these two specifications are identical; the maximum flow rate is also the maximum continuous flow rate.

The following table lists the performance specifications for the MACH 10 meter.

Table 7 – Performance Specifications

Meter Size	Extended Low Flow (100% +/- 3.0% U.S. GPM)	Normal Operating Range (100% +/- 1.5% U.S. GPM)
5/8"	0.05	0.10 to 25
3/4"	0.05	0.10 to 35
1"	0.25	0.40 to 55

Installation Instructions for MACH 10® Meters

All MACH 10® ultrasonic meters are delivered activated and ready to be installed. When the meter lid is opened, the meter shows the empty pipe icon and the latest volume on the LCD. The empty pipe icon clears immediately after the condition is corrected and the meter maincase is full.



Important! In outdoor settings, the meter and service line should be located deep enough in the ground to prevent freezing.

Installing a New Meter

The following are steps to install the MACH 10 meter.

1. Flush the service line prior to installing the meter to remove debris in the line.
2. If required, replace an electrical ground strap on the service line, connecting the inlet and outlet service lines on either side of the meter setting.



Important! Install suitable inlet and outlet meter valves and couplings / setters if they are not already present. Allow appropriate space in the line for the meter laying length and two coupling gaskets. Align the pipe ends sufficiently so that the coupling and meter threads can engage without binding or cross-threading.

3. Remove the thread protectors (if installed) before installing the meter.



Caution! Use caution, the meter threads are sharp.

4. Be sure that no debris enters the meter during installation.
5. Place the coupling gaskets and set the meter in the line.
6. Start turning the coupling or flange nuts by hand, then using a wrench tighten sufficiently to prevent leakage.



Caution! Be careful not to cross the thread connections.

7. Open the upstream inlet valve.
8. Open the meter outlet valve slowly.
9. Open a downstream faucet and run enough water to dissipate entrained air and flush the line.
10. Verify the meter is operating correctly while the faucet is open.
11. Turn OFF the faucet, and check the meter installation for leaks.

Wiring the MACH 10®

Following are the steps to wire the MACH 10 meter to an endpoint while you are in the field.



Important! If the MACH 10 meter is not prewired and potted to an endpoint, complete the following steps to wire the meter to an endpoint (if applicable).

1. Hold the Scotchlok between the index finger and thumb with the red cap facing down.

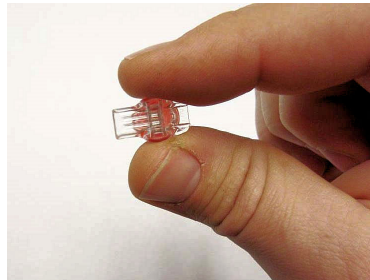

Figure 6 – Scotchlok™ Connector

2. Take one non-stripped black wire from the pigtail and one from the receptacle / endpoint.
3. Insert the wires into the Scotchlok connector.

4. Insert the insulated color wires directly into the Scotchlok connector until fully seated.

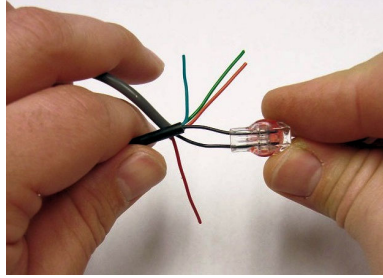

Figure 7 – Seat the Connector Wires



Caution! Do not strip the colored insulation from the wires, or strip and twist the bare wires before inserting them into the connector. Insert the insulated colored wires directly into the Scotchlok connector.

5. Place the connector red cap side down between the jaws of the UR connector crimping tool.

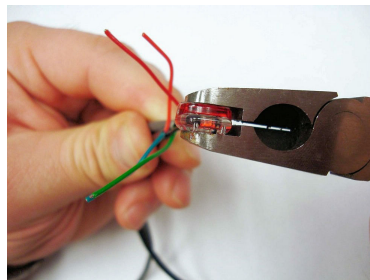

Figure 8 – Crimping Tool

6. Ensure the wires are still fully seated in the connector before crimping the connector.
7. Squeeze the connector firmly with the proper crimping tool until you hear a pop and the gel leaks out the end of the connector.
8. Repeat steps 1 through 7 for each color wire.

The following table provides the wiring color schemes for wiring the MACH 10 to various endpoint providers.



Important! The Neptune wiring scheme consists of a Black (Power/Clock) wire, a Red (Data) wire, and a Green (Ground) wire.

Table 8 – Color Codes for Wires

Endpoint Type	MACH 10 Wire Colors		
	Black (Power / Clock)	Red (Data)	Green (Ground)
Neptune R900®	Black	Red	Green
Sensus	Red	Green	Black
Itron	Black	White	Red
Aclara	Red	White	Green
Elster	Green	Red	Black
Badger	Red	Green	Black

Completing the Wiring

Follow these steps to wire the MACH 10.

1. After you connect all three color wires, read the encoder register to ensure proper connections and the receptacle / endpoint is functioning properly.

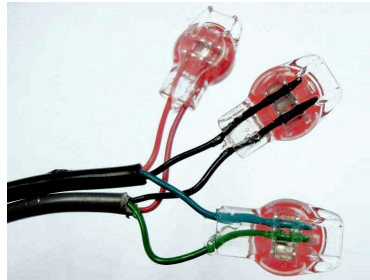

Figure 9 – Three Colored Wires Connected

2. Take all three connected Scotchloks and push them into the splice tube until fully enclosed by the silicone grease.



Figure 10 – Splice Tube

3. Separate each gray wire and place them into the slots on each side.



Figure 11 – Gray Wires in Slot

4. Snap the cover closed to finish the installation.



Figure 12 – Cover in Place

This page intentionally left blank.

Chapter 4: Operating the MACH 10[®] Ultrasonic Meter

This chapter explains the operations of the MACH 10[®] ultrasonic meter.

LCD Meter Display

The light sensor is located in the lower left of the faceplate of the MACH 10, and it activates the power for the Liquid Crystal Display (LCD) panel.



Figure 13 – MACH 10[®] LCD Display and Light Sensor

Timeout Period

Typically, the display is OFF. The meter includes a light sensor used to activate the LCD when you open the meter lid. You cannot reactivate a timed out LCD just by shining a light on the light sensor. To reset the LCD, close the lid and re-open after two seconds.

Meter Display

The MACH 10 ultrasonic meters use a nine-digit LCD to show consumption, flow rate, temperature, pressure (optional) and flag information.

LCD Panel

Following is an example of the MACH 10 LCD panel. The table on the following page provides a description of each icon.

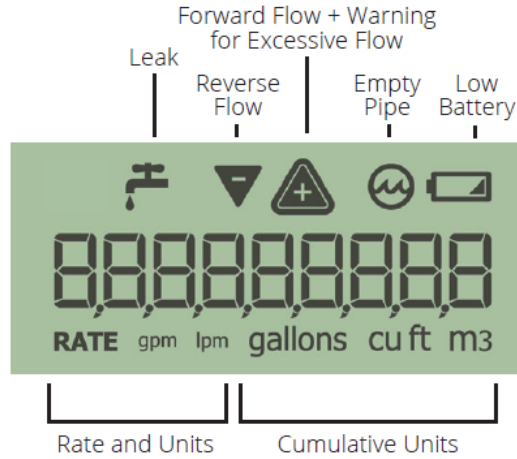

Figure 14 – MACH 10® LCD Panel



Important! The LCD can display commas or decimals, depending on the configuration of each register to show digits in the tens position, ones position, tenths position, and so forth. For example, some sizes display 1,234,567.89. Others display 123,456.789, 12,345,678.9, or 1,234,567.89 depending on the meter's size and unit of measure combination.

How to Read the Meter

It is important to become familiar with the information available from the meter. The icons and displays provide helpful information.

Flags

Indicators and flags appear in the displays as symbols that illuminate when the condition is active and disappear when the flag condition is eliminated.

LCD Icons

The following table defines the MACH 10 LCD icons and the status they indicate.

Table 9 – MACH 10® Icons and Displays







Icon	Description	Status	Explanation
Leak 	Icon used to indicate a period of continuous flow. Continuous flow status is determined by keeping track of the number of 15-minute intervals where the volume consumption exceeds Vmin in the previous 24-hour period. Vmin is factory programmed depending on meter size. It is defined as a change of the ninth digit on the LCD.	OFF	Water use has occurred in less than 50 15-minute intervals during the last 24-hour period.
		Flashing	Intermittent flow indicates that water has been used in at least 50 of the 96 15-minute intervals during the previous 24-hour period.
		ON	Indicates water use for all 96 of the 15-minute intervals during the previous 24-hour period.
Reverse and forward flow 	Icons used to indicate the reverse and forward direction of flow.	OFF	No flow is detected.
		ON	The meter has detected flow in either direction.
Excessive flow warning 	Icons used to indicate higher than normal flow conditions where the meter is incapable of measuring water use.	OFF	Flow is operating below maximum flow rate within normal flow range specifications
		ON	Flow has exceeded the maximum flow rate specification for at least 60 seconds.
Empty pipe 	Icon used to indicate a condition where the meter is incapable of measuring water use.	OFF	Meter condition is acceptable for typical operation.
		ON	Indicates less than full pipe or the presence of air in the meter for at least 60 seconds.
Battery status 	Icon used to indicate battery life of the meter.	OFF	Battery life normal.
		ON	Battery life has less than one year remaining.
		FLASHING	Battery beyond expected life; replace meter immediately.

Table 9 – MACH 10® Icons and Displays (continued)

Icon	Description	Status	Explanation
	Icon used to indicate the water temperature as registered by the meter.	ON	Temperature displays in the unit of measure defined by the utility, either Fahrenheit or Celsius.
	Icon used to indicate the water pressure as registered by the meter.	ON	Pressure displays in the unit of measure defined by the utility, either Pounds per Square Inch (PSI) or Kilopascals (kPa).

Consumption and Unit of Measure

The consumption display contains all nine digits, including leading zeros and a decimal point. The value displayed is the sum of the forward flow minus the reverse flow.

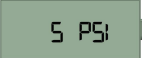
The unit of measure and resolution are factory programmed.

Table 10 – Consumption and Units of Measure

Meter Size	Capacity			Display Resolution		
	Gallons	Cubic Feet	Cubic Metres	Gallons	Cubic Feet	Cubic Metres
5/8 inch	10,000,000	1,000,000	100,000	0.01	0.001	0.0001
3/4 inch	10,000,000	1,000,000	100,000	0.01	0.001	0.0001
1 inch	10,000,000	1,000,000	100,000	0.01	0.001	0.0001

Table 11 – Available Units of Measure

Consumption	Celsius or Fahrenheit	Pressure
Gallons	F	PSI
Cubic Feet	F	PSI
Cubic Metres, Canada	C	kPa
Imperial Gallons	C	kPa
Acre-foot*	F	PSI
Litres*	C	kPa
Kilolitres*	C	kPa
Cubic Metres, International	C	kPa

*Units not available on LCD and are printed on the dial face.

The temperature and pressure units are configured in accordance with the chosen consumption measurement unit, either imperial or metric, specified during the ordering process.

Rate of Flow

The rate of flow is factory programmed for either gallons per minute or litres per minute. The LCD displays both the unit of measure and rate of flow. The rate of flow display also serves as the flow indicator. The rate of flow display is shown without leading zeros. When rate of flow is displayed, it is updated every two seconds.

Flow Direction

An arrow on the electronic register housing shows the direction of flow. Current flow direction can be viewed on the LCD panel.

The direction of flow arrows on the LCD are activated when the meter detects any amount of flow. If the volume of the flow is below a predetermined measurement threshold in each time period, the meter does not accumulate flow.

Due to the sensitivity of the meter's ability to measure, it is not uncommon to see the reverse flow icon displayed immediately after installation. This is due to the oscillation of the service water caused by the installation of the new meter. The reverse flow icon turns off shortly after continuous forward flow is recognized by the meter.

Temperature

Temperature measurement comes standard on all residential MACH 10 meters. The unit of measure for temperature is factory programmed for either Fahrenheit or Celsius. The LCD displays both the unit of measure and temperature value, as shown in the previous icons and displays table.

Pressure

The MACH 10 is available with an optional pressure sensor. Pressure observed within the flow pipe of the meter is factory programmed for either Pounds per Square Inch (PSI) or Kilopascals (kPa). The LCD displays the pressure value to the nearest whole number.

AMR / AMI Output

The Neptune MACH 10 Ultrasonic Meter is a compact design where the electronic register is fully potted and permanently sealed to the meter maincase. It communicates status reading message indicators to the Neptune R900® RF endpoints as part of the extended encoder / meter.

Endpoint Reading Resolution

The reading resolution sent to the reading software is dependent on the endpoint to which the register is connected. Readings reported from the endpoints are the left-most significant digits for the encoding reading.

Bench Testing the Meter

The Neptune MACH 10 ultrasonic meter is designed to be bench tested following typical testing practices. However, there are certain best practices you should adhere to when testing the MACH 10 meter. It is recommended that you:

- Do not mix mechanical meters with MACH 10 meters being tested. Mechanical meters alter the flow profile passing through the MACH 10 meters, which may impact accuracy.
- Place a spacer upstream of the piping elbow. However, there are no limitations in putting meters back-to-back.
- Run at least one full purge cycle before testing to assure there is no air in the meter chambers.
- Ensure the gaskets between the meter and carrier bars are properly seated to ensure the gaskets are not sliding upward into the path of the flow causing turbulence.
- Ensure there is a minimum of 30 psi back pressure on the bench while testing. This pressure must be sufficient to be recognized by all meters being tested in series.

Chapter 5: Maintenance and Troubleshooting

This chapter provides information for maintaining and troubleshooting the MACH 10[®] meter.

Maintenance

The MACH 10 ultrasonic meter does not have moving parts and requires no maintenance. The meter enclosure, which contains electronics, transducers, battery, and display, is completely potted eliminating any maintenance. At the end of the meter's life, simply replace the meter.

Replacement Parts

There are no replacement parts for the MACH 10 ultrasonic meter. If the plastic meter lid becomes damaged or broken, it can be replaced.

General Troubleshooting

Some conditions such as the following can occur:

- Battery is at low power.
- Meter starts sending colons.
- Communication stops.
- LCD not displaying.

Flush the line multiple times to ensure no air is retained within the system. Trapped air may cause the display and endpoint to report values that do not reflect actual usage. If the battery is low or if the LCD does not display, the meter is near its useful life and should be replaced.

The following tables provide steps for troubleshooting common issues with the MACH 10 meter.

Table 12 – Errors When LCD Does Not Display

Possible Cause	Remedy
Environment is too dark	Shine a flashlight on the face of the register. Remove the light after the display wakes up.
LCD has timed out	<ul style="list-style-type: none">• Close the lid of the register.• After a few seconds open the lid. If the LCD still does not come on, see “Possible Cause: Environment is too dark” above.
Photo-eye is blocked	Clean the face of the register to remove any dirt and debris, and then follow the steps in “Possible Cause: LCD has timed out” above.

Table 13 – Errors When Flow Icons are Displayed

Possible Cause	Remedy
Intermittent or continuous flow	Depending on the application of the meter, intermittent or continuous flow may be expected. If such flow is unexpected, check the integrity of the line downstream of the meter.
Reverse flow	Some reverse flow may be expected depending on your configuration. You may need to install a backflow preventer if significant negative flow is reported.
Excessive Forward Flow	The meter may be the wrong size for this installation. Check the flow rate of the site and recommended flow rates for the MACH 10 meters.
Empty Pipe	Remove all air from the meter during installation. Neptune recommends flushing the line multiple times to ensure no air is retained within the system. Trapped air may cause the display and endpoint to report values that do not reflect actual usage.
Low Battery	If the battery is low, the meter is near its useful life and should be replaced.

Checklist

Before leaving the installation site, be sure to do the following.

- Record the endpoint ID for each register.
- Verify that you have followed all requirements of this Installation and Maintenance Guide.
- Verify that you have recorded all required information.
- Clean up any installation debris.
- Verify that the requirements of the Site Work Order have been completed.
- Inform the customer that you have completed your work. If you were unable to finish, inform the customer when you are returning to complete the project.

Contact Information

Neptune Customer Support is available in the United States Monday through Friday, 7:00 A.M. to 5:00 P.M. Central Time by telephone or email.

By Phone

To contact Neptune Customer Support by phone, call (800) 647-4832 and complete the following steps.

Press one of the following:

- **1** for Customer Service.
- **2** for System Support.
- **3** for Return Material Authorizations (RMAs).
- **4** for Subscriptions or Renewals.
- **5** for Customer Success and Onboarding.

For System Support or Customer Success and Onboarding, press one of the following:

- **1** if you know your site ID.
- **2** to input your PIN or if you do not have a PIN.

For RMAs, press one of the following:

- **1** for reading device support.
- **2** for meter, endpoint, and register support.

Neptune Customer Support Specialists are dedicated to you until the issue is resolved to your satisfaction. When you call, be prepared to provide the following information:

- Your name and a callback number.
- Your utility name, company name, or site ID / PIN.
- A description of what occurred and what you were doing at the time.
- A description of any actions taken to correct the issue.

By Email

To contact Neptune Customer Support by email, send your message to support@neptunetg.com.

This page intentionally left blank.

This appendix provides a general description of the MACH 10[®])R900i™ and the flags the MACH 10 generates.

Product Description

The MACH 10[®])R900i™ is an integrated register that contains both the MACH 10 meter and the R900[®] radio technologies in one assembly that collects and transmits data. A Neptune walk-by, mobile, or R900[®] gateway fixed network data collection system receives the data in the Neptune 360 head-end software to be downloaded into the utility billing system for processing.

The MACH 10[®])R900i™ is easily installed and operates within a Radio Frequency (RF) band, which does not require an operating license. The MACH 10[®])R900i™ meets FCC regulations part 15.247 allowing higher output power and greater range. The MACH 10[®])R900i™ uses frequency-hopping spread spectrum (FHSS) technology to avoid RF interference and enhance security.

The transmitted data is updated at 15-minute intervals. It transmits a mobile message that includes the meter reading data and the unique 10-digit MACH 10 ID every 14 to 20 seconds. This allows the meter to be read by a handheld unit (HHU) or mobile data collection unit. The MACH 10[®])R900i™ also transmits a high-power fixed network message every 7½ minutes on an interleaved basis to a R900[®] gateway.

The MACH 10[®])R900i™ is designed to offer advantages to utility organizations of all sizes:

- Increases meter reading accuracy by eliminating manual entry.
- Eliminates reading difficulties, such as hard to reach meters.
- Protects utility liability by increasing meter reader safety.
- Improves operational efficiency by not requiring external wiring or programming.
- Provides enhanced eight-digit AMR meter reading.
- Increased frequency of data provides proactive customer service benefits (continuous flow, tamper, and reverse flow detection).



Figure 15 – MACH 10®)R900i™ Integrated Meter

MACH 10®)R900i™ Programming

The MACH 10 is not field-programmable. Each endpoint is given a unique 10-digit serial number / identification number.

MACH 10®)R900i™ Specifications

This section provides you with the specifications for the MACH 10®)R900i™.

Electrical Specification

Power is provided by a 3.6 volt lithium thionyl-chloride battery.

Transmitter Specifications

The following table defines the specifications for the MACH 10®)R900™ transmitter.

Table 14 – Transmitter Specifications

Specification	R900i	LoRaWAN R900™
Transmit Period	<ul style="list-style-type: none"> • Every 14 seconds (Mobile). • Every 7.5 minutes (Fixed Network). 	<ul style="list-style-type: none"> • Every 20 seconds (Mobile). • Every 7.5 minutes (Fixed Network). • Every 3 hours (LoRaWAN).
Transmit Channels	50 (Mobile / Fixed).	50 (Mobile / Fixed). 64 (LoRaWAN).
Transmit Frequency	910 to 920 MHz.	902 to 928 MHz.
Output Power	Up to 1 watt.	
FCC Verification	Part 15.247.	

Environmental Conditions

This table defines environmental conditions that apply to the MACH 10®)R900™ meters. The temperature meets AWWA C-715 accuracy specifications for water temperatures from 33° to 122° F (+0.5 C to 50° C).

Table 15 – Environmental Conditions

Conditions	Description
Operating temperature	14° to 149° F (-10° to 65° C)
Storage temperature	-40° to 158° F (-40° to 70° C)
Water temperature	33° to 122° F (+0.5° to 50° C)
Operating humidity	0 to 100% condensing

Functional Specifications

The following table defines the functional specifications for the MACH 10®)R900i™.

Table 16 – Functional Specifications

Specification	Description
Register Reading	<ul style="list-style-type: none"> • Eight digits (AMR / AMI). • Nine digits (Visual).
Endpoint ID	Endpoint ID number –10 digits.

Dimensions

The following images show the dimensions of the residential MACH 10®)R900i™.

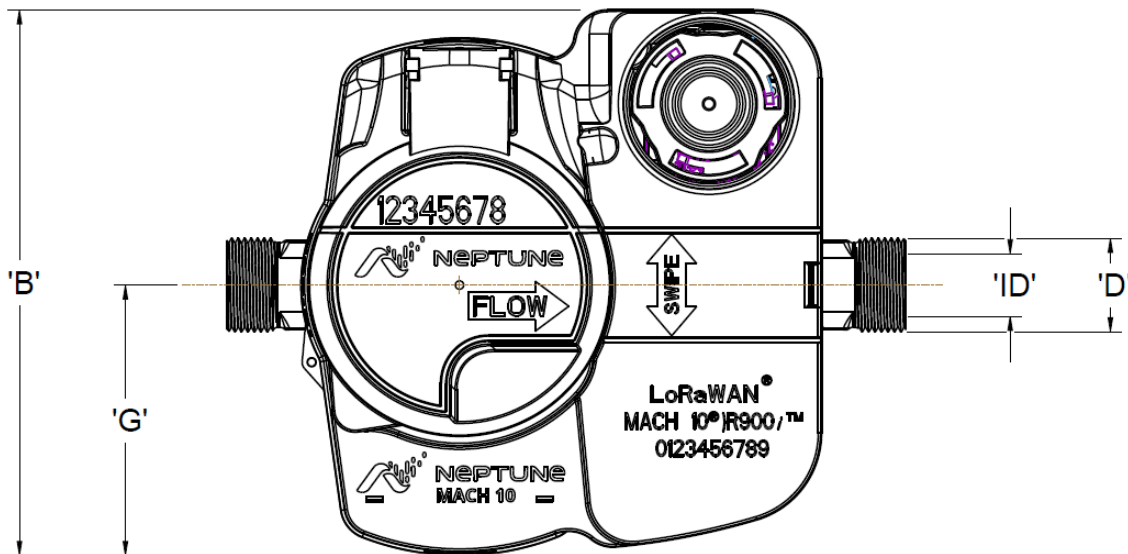

Figure 16 – MACH 10®)R900i™ – Top View

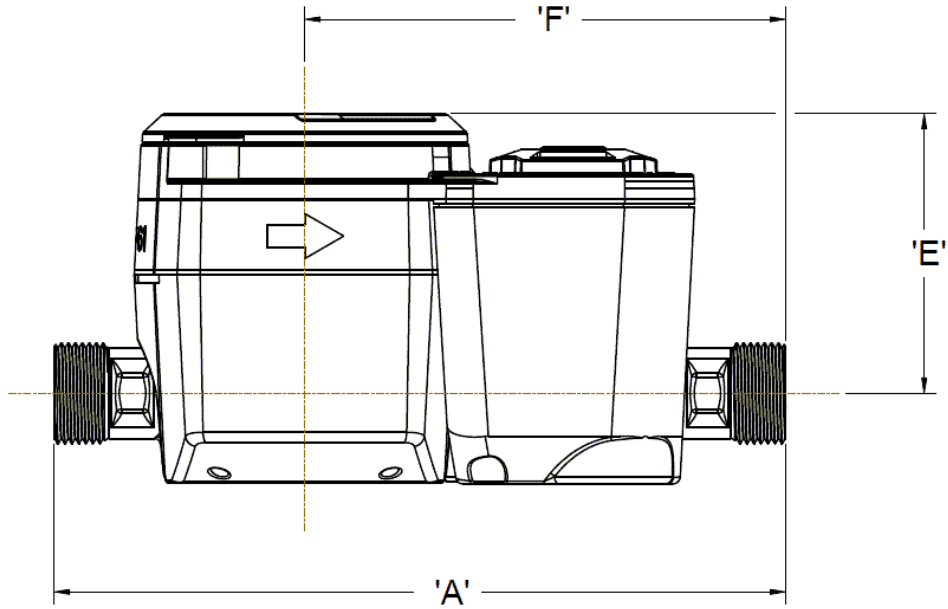

Figure 17 – MACH 10®)R900™ – Side View

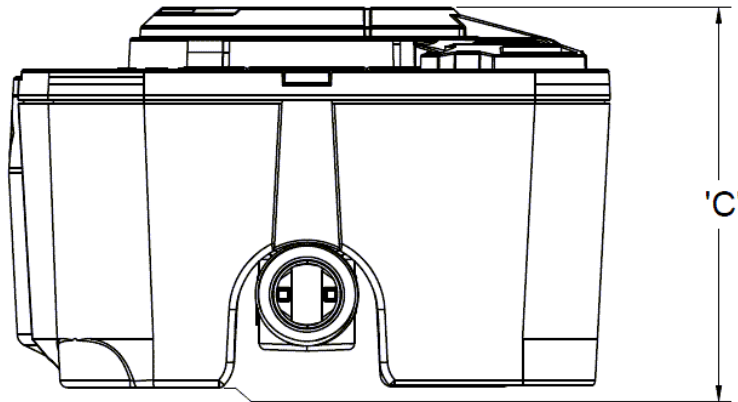

Figure 18 – MACH 10®)R900™ – Front View

The following table defines the dimensions of the MACH 10®)R900™ meters. All dimension measurements are in inches.

Table 17 – Residential MACH 10[®]R900i™ Dimensions in Inches

Meter Size	A	B	C	D	E	F	G	ID
5/8 x 5/8 inch	7.50	6.02	3.78	5/8 inch thread	2.86	4.93	3.00	ø .69
5/8 inch x 3/4 inch	7.50	6.02	3.78	3/4 inch thread	2.86	4.93	3.00	ø .69
3/4 x 3/4 inch	9.00	6.02	3.78	3/4 inch thread	2.90	5.75	3.00	ø .83
3/4 inch SL	7.50	6.02	3.78	3/4 inch thread	2.90	5.00	3.00	ø .83
3/4 inch x 1 inch	9.00	6.02	3.78	1 inch thread	2.90	5.75	3.00	ø .83
1 x 1 inch	10.75	6.02	3.78	1 inch thread	3.04	7.09	3.00	ø 1.05
1 inch x 1-1/4 inch	10.75	6.02	3.78	1 – 1-1/4 inch thread	3.04	7.09	3.00	ø 1.05

Flags

These tables describe the volume represented by the eighth digit and the flags the MACH 10[®]R900i (digits) and MACH 10[®]R900i uses by meter size.

Table 18 – Eighth Digit Resolution by Meter Size

Register Size	Eighth Digit Resolution - Least Significant Digit
(5/8 inch – 1 inch)	1/10 U.S gallons or 1/100 cubic feet.

Table 19 – MACH 10[®]R900i™ Flags (digits)

Reverse Flow Flags (Resets After 35 Days)	
Based on reverse movement of the eighth digit; eighth digit is variable based on the meter size.	
No reverse flow event	Eighth digit reversed less than one digit.
Minor reverse flow	Eighth digit reversed more than one digit up to 100 times the eighth digit.
Major reverse flow event	Eighth digit reversed greater than 100 times the eighth digit.

Table 20 – Continuous Flow Flags

Continuous Flow Status Flag (Resets After 35 Days)	
Based on total amount of 15-minute periods recorded in the previous 24-hour period.	
Continuous flow icon off	Eighth digit incremented less than 50 of the 96 15-minute intervals.
Flashing continuous flow icon	Eighth digit incremented in 50-95 of the 96 15-minute intervals.
Solid continuous flow icon	Eighth digit incremented in all of the 96 15-minute intervals.
Consecutive Days with Zero Consumption Flag (Resets After 35 Days)	
Number of days the continuous flow status was at a minimum value.	

This page intentionally left blank.

A

acre-foot

A unit of volume equal to the volume of a sheet of water one acre (0.405 hectare) in area and one foot (30.48 cm) in depth, which is a total of 43,560 cubic feet (1233.5 cubic metres).

AMI

Advanced Metering Infrastructure. A system that captures, stores, and provides to the utility at frequent intervals detailed consumption and other information, such as, usage, leak, and flow status, to support advanced applications.

AMR

Automated or Automatic Meter Reading.

AWWA

American Water Works Association.

E

Empty Pipe

Condition whenever the measurement section of the meter is not completely filled with water.

K

Kilopascal

Metric unit of measure for pressure. A Kilopascal (kPa) is 1,000 pascals.

kPa

Kilopascal.

L

LCD

Liquid Crystal Display.

light sensor

Component located under the recess that is used to activate the Liquid Crystal Display (LCD).

P

Pounds per Square Inch (PSI)

Imperial unit of measure for pressure.

PSI

Pounds per Square Inch.

psig

Pressure in pounds per square inch (psi) relative to atmospheric pressure, as typically shown on a pressure gauge.

S

serial number

Unique identification number given to each meter at the factory. The default value is the last programmed plus one.

T

transceiver

Device that transmits and receives communications, in particular a combined radio transmitter and receiver.

transducer

Device that converts one form of energy to another form of energy.

transit-time

Technology that takes advantage of the principle that an acoustic signal travels faster with the flow than against the flow.

U

ultrasonic flow

Use of ultrasonic technology to measure the velocity of an acoustically conductive liquid or gas moving through it. The velocity of the water is then converted to volume throughput using sophisticated algorithms and electronics.

ultrasonic meter

Electronic meter using ultrasonic technology and solid-state electronics contained in a compact, totally encapsulated, weatherproof, and ultraviolet (UV) resistant housing for residential and light commercial applications.

This page intentionally left blank.

A

acoustic signal 2

acoustically 1

alarm 20

algorithms 1

AMI 1, 3

AMR 1

B

backflow 34

battery 1, 25

 requirements 8

C

calculated velocity 2

calibrated 10

Celsius 24

checks

 preliminary 10

 safety 10

color codes for wires 15

conductive 1

connections 15

consumption 19, 22

contaminants 1

crimping tool 14

D

dimensions

 residential meter 6, 32

F

Fahrenheit 24

faucet 5

fire service 8

fixed network 29

flashlight 9

H

hopping, frequency 29

I

icon

 battery status 21

 forward and reverse flow 21

 high flow warning 21

 leak 21

installation

 meter 10

installing 9

integrated 3

K

Kilopascals 24

kPa 24

L

LCD 19

panel 19

light sensor 19

M

MACH 10®

MACH 10®)R900j™

programming 30

specifications 30

transmitter 31

MACH 10® 1

maincase 8

maintenance 25

meter

display 19

sizing 11

O

operating license 29

output 24

P

piezoelectric 8

pipng 10

potted 3, 24

product description 1

R

reading resolution 24

recommended

materials 9

tools 9

reflectors 8

register

display 5, 31

type 5, 31

resolution 22

retrofit 10

RF

band 29

protocol error 30

S

sealed 3

specifications

MACH 10® 5

T

temperature, water 10

toolkit 9

transceivers 2

transducers 2

transit-time 2

troubleshooting 25

V

velocity range 8

W

wetted 8



Neptune Technology Group Inc.

1600 Alabama Highway 229
Tallassee, AL 36078
USA Tel: (800) 633-8754
Fax: (334) 283-7293

Neptune Technology Group Canada Co.

7275 West Credit Avenue
Mississauga, Ontario L5N 5M9
Canada Tel: (905) 858-4211
Fax: (905) 858-0428

Neptune Technology Group Inc.

Avenida Ejercito Nacional No 418
Piso 12, Despacho 1203
Colonia Polanco V Sección
C.P. 11560 Delegación, Miguel Hidalgo
Mexico D.F.
Tel: (55) 5203-5708, (55) 5203-4032,
(55) 5203-5294

Online
www.neptunetg.com