

# CHEM-PRO<sup>®</sup> M

Diaphragm Metering Pumps



**Ti SALES**

36 Hudson Rd  
Sudbury MA 01776



800-225-4616  
www.tisales.com

## SERIES MC-2 / MC-3

Operating Manual



**ProSeries<sup>®</sup>**  
by Blue-White Ind.



5300 Business Drive, Huntington Beach, CA 92649 USA

Phone: 714-893-8529 FAX: 714-894-9492

E mail: sales@blue-white.com | techsupport@blue-white.com URL: www.ProSeries-M.com

## TABLE OF CONTENTS

<u>Section</u>	<u>Heading</u>	<u>Page</u>
1.0	Introduction . . . . .	3
1.1	Available Models . . . . .	3
2.0	Specifications . . . . .	4
2.1	Materials of Construction . . . . .	4
3.0	Features . . . . .	5
3.1	Agency Listings . . . . .	5
4.0	Installation. . . . .	6
4.1	Mounting Location . . . . .	6
4.2	Dimensions . . . . .	6
4.3	Installing Injection Fitting and Strainer . . . . .	7
5.0	Power Connections . . . . .	8
5.1	Wiring Terminal and I/O Schematics . . . . .	9
6.0	How to Operate Chem-Pro - Control Pad . . . . .	10
6.1	Mode Descriptions . . . . .	11
7.0	Mode 0 - Set Remote Start/Stop . . . . .	12
7.1	Mode 0 - Set DFD Sensitivity . . . . .	13
7.2	Mode 0 - Set FVS (flow verification system). . . . .	14, 15
7.3	Mode 0 - Set 4-20mA Output. . . . .	16, 17
7.4	Mode 0 - Set Flow Rate (Pump Calibration). . . . .	18, 19
7.4.1	Mode 0 - Operation Screens Displaying Flow Rate. . . . .	19
8.0	Mode 1 - Manual Operation . . . . .	20, 21
8.1	Mode 1 - Manual Operation Screen Shots . . . . .	21
9.0	Mode 2 - 4-20mA Input Operation . . . . .	22, 23
9.1	Mode 2 - 4-20mA Input Screen Shots . . . . .	23
10.0	Mode 3 - Frequency Input (Hz) Operation . . . . .	24, 25
11.0	Mode 4 - Pulse Batch (low speed pulse) Operation . . . . .	26, 27
11.1	Mode 4 - Pulse Batch Operation Screen Shots . . . . .	27
12.0	Alarm Relay. . . . .	28
13.0	Volumetric Test - Calibration . . . . .	28
14.0	Pump Maintenance . . . . .	29
14.1	Routine Inspection and Maintenance. . . . .	29
14.2	Cleaning Pump . . . . .	29
14.3	Motor Brush Replacement . . . . .	30
	Blank Page . . . . .	31
15.0	Replacement Parts List . . . . .	32
15.1	MC-2 Parts List . . . . .	32
15.2	MC-3 Parts List . . . . .	33
16.0	DFD (Diaphragm Detection System) . . . . .	34
17.0	Output Versus Pressure . . . . .	35
17.1	MC-2 Output V. Pressure . . . . .	35
17.2	MC-3 Output V. Pressure . . . . .	35
	Warranty . . . . .	36

PLEASE READ ENTIRE INSTRUCTION MANUAL PRIOR TO INSTALLATION AND USE.

## 1.0 Introduction

Congratulations on purchasing Chem-Pro® variable speed Diaphragm Metering Pump. A diaphragm pump is a type of positive displacement pump used for pumping a variety of fluids.

Your Chem-Pro® pump is pre-configured for diaphragm, pump head and fittings that shipped with your metering pump.

**Please Note:** Your new pump has been pressure tested at the factory with clean water before shipping. You may notice trace amounts of clean water in pump head. This is part of our stringent quality assurance program at Blue-White Industries.

## 1.1 Available Models

<b>MC-2 Diaphragm Metering Pump</b>							
166 Strokes per minute							
Feed Rate Range at 0 PSIG			Max Pressure	Connection Type	MC-2 Model Numbers		
GPH	LPH	ML/MIN	PSIG (bar)	Size / Type	115V60 AC	230V60 AC	220V50 AC
.01 - 2.3	.05 - 9.0	0.8 - 150	150 (10)	½" Male NPT	MC-2245XV3	MC-2255XV3	MC-2265XV3
.01 - 2.3	.05 - 9.0	0.8 - 150	150 (10)	½" Female /NPT	MC-2245XV4	MC-2255XV4	MC-2265XV4
.01 - 2.3	.05 - 9.0	0.8 - 150	150 (10)	3/4"OD x 1/2"ID TUBE	MC-2245XV1	MC-2255XV1	MC-2265XV1
.01 - 2.3	.05 - 9.0	0.8 - 150	150 (10)	3/8"OD x 1/4"ID TUBE	MC-2245XV2	MC-2255XV2	MC-2265XV2
.03 - 6.7	.13 - 25.4	2.1 - 423	175 (12)	½" Male NPT	MC-2243XV3	MC-2253XV3	MC-2263XV3
.03 - 6.7	.13 - 25.4	2.1 - 423	175 (12)	½" Female NPT	MC-2243XV4	MC-2253XV4	MC-2263XV4
.03 - 6.7	.13 - 25.4	2.1 - 423	175 (12)	3/4"OD x 1/2"ID TUBE	MC-2243XV1	MC-2253XV1	MC-2263XV1
.03 - 6.7	.13 - 25.4	2.1 - 423	175 (12)	3/8"OD x 1/4"ID TUBE	MC-2243XV2	MC-2253XV2	MC-2263XV2
.02 - 4.0	.08 - 15.0	1.3 - 250	150 (10)	½" Male NPT	MC-2246XV3	MC-2256XV3	MC-2266XV3
.02 - 4.0	.08 - 15.0	1.3 - 250	150 (10)	½" Female /NPT	MC-2246XV4	MC-2256XV4	MC-2266XV4
.02 - 4.0	.08 - 15.0	1.3 - 250	150 (10)	3/4"OD x 1/2"ID TUBE	MC-2246XV1	MC-2256XV1	MC-2266XV1
.02 - 4.0	.08 - 15.0	1.3 - 250	150 (10)	3/8"OD x 1/4"ID TUBE	MC-2246XV2	MC-2256XV2	MC-2266XV2
.05 - 10	.19 - 38	3.2 - 631	175 (12)	½" Male NPT	MC-2241XV3	MC-2251XV3	MC-2261XV3
.05 - 10	.19 - 38	3.2 - 631	175 (12)	½" Female /NPT	MC-2241XV4	MC-2251XV4	MC-2261XV4
.05 - 10	.19 - 38	3.2 - 631	175 (12)	3/4"OD x 1/2"ID TUBE	MC-2241XV1	MC-2251XV1	MC-2261XV1
.05 - 10	.19 - 38	3.2 - 631	175 (12)	3/8"OD x 1/4"ID TUBE	MC-2241XV2	MC-2251XV2	MC-2261XV2
.08 - 16.5	.31 - 62.5	8.25 - 1041	175 (12)	½" Male NPT	MC-2242XV3	MC-2252XV3	MC-2262XV3
.08 - 16.5	.31 - 62.5	8.25 - 1041	175 (12)	½" Female /NPT	MC-2242XV4	MC-2252XV4	MC-2262XV4
.08 - 16.5	.31 - 62.5	8.25 - 1041	175 (12)	3/4"OD x 1/2"ID TUBE	MC-2242XV1	MC-2252XV1	MC-2262XV1
.08 - 16.5	.31 - 62.5	8.25 - 1041	175 (12)	3/8"OD x 1/4"ID TUBE	MC-2242XV2	MC-2252XV2	MC-2262XV2

<b>MC-3 Diaphragm Metering Pump</b>							
130 Strokes per minute							
Feed Rate Range at 0 PSIG			Max Pressure	Connection Type	MC-2 Model Numbers		
GPH	LPH	ML/MIN	PSIG (bar)	Size / Type	115V60 AC	230V60 AC	220V50 AC
.13 - 26.2	.5 - 99	8.25 - 1650	150 (10.3)	½" Male NPT	MC-3141XV3	MC-3151XV3	MC-3161XV3
.13 - 26.2	.5 - 99	8.25 - 1650	150 (10.3)	½" Female /NPT	MC-3141XV4	MC-3151XV4	MC-3161XV4
.13 - 26.2	.5 - 99	8.25 - 1650	150 (10.3)	3/4"OD x 1/2"ID TUBE	MC-3141XV1	MC-3151XV1	MC-3161XV1
.20 - 40.6	.77 - 154	12.8 - 2560	100 (6.8)	½" Male NPT	MC-3142XV3	MC-3152XV3	MC-3162XV3
.20 - 40.6	.77 - 154	12.8 - 2560	100 (6.8)	½" Female NPT	MC-3142XV4	MC-3152XV4	MC-3162XV4
.20 - 40.6	.77 - 154	12.8 - 2560	100 (6.8)	3/4"OD x 1/2"ID TUBE	MC-3142XV1	MC-3152XV1	MC-3162XV1

•Chem-Pro® Pumps motor speed is linear over the entire 0.5% to 100% adjustment range.

•Output versus pressure is nearly linear in all models.

•Feed rates taken in laboratory environment with clean water after 20 minute diaphragm break-in period with a 3 foot (1 meter) suction lift.

## 2.0 Specifications

### Maximum working pressure\*:

175 psig (12 bar), \*model specific

### Maximum Fluid temperature (excluding pump tubes):

130° F (54° C)

### Maximum fluid viscosity:

1,000 Centipoise

### Maximum suction lift:

15 ft. Water, 0 psig (4.5 m, 0 bar)

### Ambient Operating Temperature

14°F to 115°F (-10°C to 46°C)

### Ambient Storage Temperature

-40°F to 158°F (-40°C to 70°C)

### Operating Voltage:

115VAC/60Hz, 1ph (1.5 Amp Maximum)

230VAC/60Hz, 1ph (0.7 Amp Maximum)

220VAC/50Hz, 1ph (1.0 Amp Maximum)

240VAC/50Hz, 1ph (1.0 Amp Maximum)

### Power Cord Options:

115V60Hz = NEMA 5/15 (USA)

230V60Hz = NEMA 6/15 (USA)

220V50Hz = CEE 7/VI (EU)

240V50Hz = AS 3112 (Australia/New Zealand)

### Motor:

Brushed DC, 1/8 H.P.

### Duty cycle:

Continuous

### Motor speed adjustment range 200:1:

0.5% - 100% motor speed

### Motor speed adjustment resolution:

0.1% increments

### Accuracy:

+/- 2% of full scale

Repeatability +/- 0.5%

### Display

Backlit LCD, UV resistant.

### Keypad

Five button positive action tactile switch keypad.

### Enclosure:

NEMA 4X (IP66), Powder coated aluminum.

Maximum overall dimensions:

MC-2 models: 11-3/4"W x 7-3/4"H x 10-3/4"D (298W x 197H x 274D mm)

MC-3 models: 13-1/8"W x 9"H x 10-3/4"D (333W x 228H x 274D mm)

### Approximate shipping wt:

MC-2 models: 24 lb. (10.9 Kg)

MC-3 models: 29 lb. (13.1 Kg)

## 2.1 Materials of construction

### Wetted components:

#### Pump Head Assembly:

Pump Head: .....PVDF

Adapter Connections: .....PVDF

Prime/Degassing Valve: .....PVDF

Valve Cartridges: .....PVDF

Valve Balls: .....Ceramic

Valve Ball Seats: .....TFE/P

Tetrafluorethylene/propylene

Static Seals: .....TFE/P (optional EP)

Diaphragm: .....PVDF. Flex-A-Prene®

#### Foot Valve / Strainer:

Body & Adapter: .....PVDF

Check Ball: .....Ceramic

Spring: .....Hastelloy C-276

O-ring seals: .....TFE/P (optional EP)

Filter screen: .....PVDF

### Non-Wetted components:

#### Enclosure:

413 Aluminum (Polyester powder coated)

#### Pump Head Cover:

316 SS (Polyester powder coated)

#### Cover Screws:

300 Series Stainless Steel

#### DFD System Sensor pins:

Hastelloy C-276

#### Power Cord:

3 conductor, SJTW-A Water-resistant

#### Mounting Brackets and Hardware:

316 Series Stainless Steel

### 3.0 Features

Motor driven diaphragm pump offers smooth and quiet chemical dosing. No hard pulses as seen with solenoid driven pumps.

Full stroke every time avoids vapor lock.

Variable speed DC motor.

Rated for continuous duty (24X7).

PVDF / Ceramic pump head components.

Diaphragm Failure Detection (DFD) system. Senses diaphragm failure by detecting chemical in pump head.

Backlit LCD displays motor speed, input signal values, service and alarm status.

CNC precision machined cam and piston for optimum efficiency, unparalleled accuracy, and linearity.

Heavy duty PVDF pump head and valves are standard.

Compatible with Blue-White's output Flow Verification Sensor (FVS) system.

Includes stainless steel extended mounting brackets. Lifts pump 4-1/2" (11.43 cm), for easy access in hard to reach areas.

### 3.1 Agency Listings



This pump is certified to NSF/ANSI Standard 61 - Drinking Water System Components - Health Effects



Intertek

This pump is ETL listed to conform to the following:  
UL Standard 778 as a motor operated water pump  
CSA Standard C22.2 as process control equipment



This pump complies to the Machinery Directive 98/37/EC, BS EN 60204-1, Low Voltage Directive 73/23/EC BS EN 61010-1, EMC Directive 89/336/EC, BS EN 50081-1/BS EN 50082-1.

Symbol	Explanation
	WARNING, risk of electric shock
	CAUTION, refer to users' guide
	GROUND, PROTECTIVE CONDUCTOR TERMINAL

#### Enclosure Rating:

**NEMA 4X:** Constructed for either indoor or outdoor use to provide a degree of protection to personnel against incidental contact with enclosed equipment; to provide a degree of protection against falling dirt, rain, sleet, snow, windblown dust, splashing water, and hose-directed water; and that will be undamaged by external formation of ice on enclosure.

**IP66:** No ingress of dust; complete protection against contact. Water projected in powerful jets against enclosure from any direction shall have no harmful effects.

## 4.0 Installation

<b>CAUTION</b> ⚠	Risk of chemical overdose. Be certain pump does not overdose chemical during backwash and periods of no flow in circulation system.
<b>CAUTION</b> ⚠	Always wear protective clothing, face shield, safety glasses and gloves when working on or near your metering pump. Additional precautions should be taken depending on solution being pumped. Refer to MSDS precautions from your solution supplier.
<b>CAUTION</b> ⚠	All diagrams are strictly for guideline purposes only. Always consult an expert before installing metering pump on specialized systems. Metering pump should be serviced by qualified persons only.

### 4.1 Mounting Location

Choose an area located near chemical supply tank, chemical injection point, and electrical supply. Install pump where it can be easily serviced.

316SS Mounting brackets are included. Mount pump to a secure surface using enclosed mounting hardware.

Mount pump close to injection point. Keep inlet (suction) and outlet (discharge) plumbing as short as possible. Longer discharge plumbing increases back pressure at pump head.

**Important!** Install a back flow prevention check valve at discharge side of pump to prevent system fluid from flowing back through pump during pump maintenance. **Important!**

A pressure relief valve is recommended at discharge of pump.

### 4.2 Dimensions

The technical drawings show the metering pump from three perspectives: Top, Front, and Right. Dimension lines A through J indicate specific measurements. The Top view shows dimensions A (width), B (height), C (depth), and D (mounting bracket height). The Front view shows dimensions E (width), F (height), G (total height with bracket), and H (height to top of pump). The Right view shows dimension J (width).

MC-2 Dimensions			MC-3 Dimensions		
Dim	Inches	cm	Dim	Inches	cm
A	14.1"	32.5	A	14.1"	35.8
B	11.5"	29.2	B	12"	30.5
C	3.7"	9.5	C	3.7"	9.5
D	2.5"	6.4	D	2.5"	6.4
E	13.1"	29.9	E	13.1"	33.2
F	7.9"	20.1	F	9"	22.9
G	7.3"	18.4	G	7.8"	19.8
H	6.5"	16.4	H	6.5"	16.4
I	15"	34.6	I	15"	38
J	8"	20.3	J	8"	20.3

**Note:** Included Extended Bracket adds 4.5" (11.43cm) to overall height (dimension G and H).



### 4.3 Foot Valve / Strainer

**CAUTION** Proper eye and skin protection must be worn when installing and servicing pump.

**CAUTION** This Pump Has Been Evaluated for Use with Water Only.

<p>1/2" (1.3cm) I.D. Hose Barb Fitting Foot valve / strainer.</p>	<p>1/4" (.64cm) I.D. Tube Compression Fitting Foot valve / strainer.</p>	<p>1/2" (1.3cm) Male NPT Foot valve / strainer.</p>
<p><b>Part Numbers:</b> 71000-575 - 1/2" Barb valve, Viton 71000-576 - 1/2" Barb valve, EP</p>	<p><b>Part Numbers:</b> 71001-005 - 1/4" ID Tube, Viton 71001-006 - 1/4" ID Tube, EP</p>	<p><b>Part Numbers:</b> 71000-849 - 1/2" M/ NPT valve, Viton 71000-850 - 1/2" M/NPT valve, EP</p>

## 5.0 Power Connections

<b>WARNING</b> 	Risk of electric shock – cord connected models are supplied with a grounding conductor and grounding-type attachment plug. To reduce risk of electric shock, be certain that it is connected only to a properly grounded, grounding-type receptacle.
<b>WARNING</b> 	Electrical connections and grounding (earthing) must conform to local wiring codes. Be certain that a grounding conductor is connected to terminal T11-1 located in wiring compartment.
<b>WARNING</b> 	Risk of electric shock - Disconnect electricity before removing wiring compartment cover.

Be certain to connect pump to proper supply voltage. Using incorrect voltage will damage pump and may result in injury. Voltage requirement is printed on pump serial label.

Input power: 115VAC 50/60 Hz 1.5 amp or 230/240VAC 50/60 Hz 0.7 amp.

Power switch located in Junction Box.

Use voltage your power cord is rated for.

Cord connected models are supplied with a ground wire conductor and a grounding type attachment plug (power cord). To reduce risk of electric shock, be certain that power cord is connected only to a properly grounded, grounding type receptacle.

Permanently connected models must be properly grounded. Be certain that a grounding conductor is connected to terminal T11-1 located in wiring compartment.

Never strap control (input / output) cables and power cables together.

**Power Interruption:** This pump has an auto-restart feature which will restore pump to operating state it was in prior to power loss.

**Note:** When in doubt regarding your electrical installation, contact a licensed electrician.

### WIRING COMPARTMENT COVER

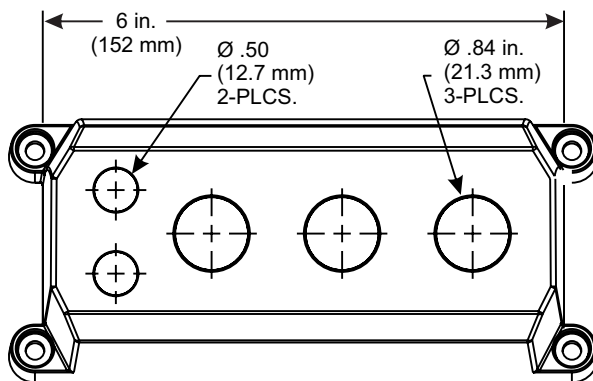

### POWER CORD OPTIONS

Four power cord plug types available.  
Power cord length is 6 feet (3.83 meters)



115V 60Hz  
NEMA 5/15 (USA)  
max: 125V AC

230V 60Hz  
NEMA 6/15 (USA)  
max: 250V AC

240V 50Hz  
CEE 7/VII (EU)  
max: 250V AC

### Included cable and conduit connectors:

QTY.	DESCRIPTION
Qty: 2	.50 Inch (12.7 Mm) Liq-tight Hole Plugs (mat'l = Neoprene), Pre-installed
Qty: 3	.875 Inch (22.2 Mm) Liq-tight Hole Plugs (mat'l = Neoprene), 2 Pre-installed
Qty: 2	.50 Inch (12.7 Mm) Liq-tight Connectors For Pass Thru Cords (mat'l = Nylon) Acceptable Cable Diameter .12 To .26 Inch (3.0 To 6.5 Mm), Not Installed
Qty: 3	.875 Inch (22.2 Mm) Liq-tight Connectors For Pass Thru Cords (mat'l = Nylon) Acceptable Cable Diameter .20 To .40 Inch (5.1 To =10.0 Mm), 1 Pre-installed W/ Power Cord Models
Qty: 2	Metallic Liq-tight Connectors For .50 Inch Flexible Conduit (mat'l = Die Cast Zinc), Not Installed



### 5.1 Wiring Terminals and I/O Schematics

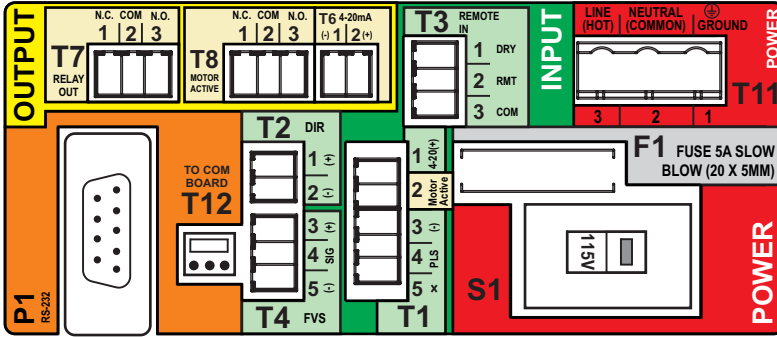

**WARNING** Risk of electric shock - All wiring must be insulated and rated 300V minimum.

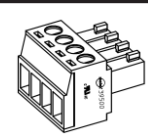

Terminals T1 Thru T8  
Plug type  
16 - 24 AWG

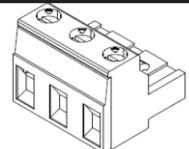

Power Input Terminal T11  
Plug type  
14 - 30 AWG

Shielded cables should be used on all input signal wires.

FUNCTION	TERM	PIN #	RATING	ELECTRICAL SP.	BLOCK DIAGRAM
INPUT: 4-20 mA	T1	1	(+) POSITIVE	120 OHM IMPEDANCE, NON POWERED LOOP	<p>Single or dual pump (series) input. Loop voltage must not exceed 24 Volts.</p> <p>ACTIVE 4-20mA TRANSMITTER SOURCE</p>
	T1	3	(-) NEGATIVE		
INPUT: FREQUENCY, AC SINE WAVE, TTL, CMOS	T1	3	(-) NEGATIVE	0-1000 HZ MAX.	<p>FREQUENCY TRANSMITTER SOURCE</p>
	T1	4	(+) POSITIVE		
INPUT: FVS SYSTEM (FLOW VERIFICATION SENSOR) FV SENSOR ONLY	T4	3	(+) POSITIVE		<p>BLUE-WHITE FVS SENSOR</p>
	T4	4	SIGNAL		
	T4	5	(-) NEGATIVE		
INPUT: FVS SYSTEM (FLOW VERIFICATION SENSOR) FS or FP MICRO-FLO FLOW METER ONLY	T4	4	SIGNAL		<p>BLUE-WHITE MICRO-FLO FLOWMETER PULSE OUTPUT</p>
	T4	5	(-) NEGATIVE		
	T4	5	(-) NEGATIVE		
INPUT: REMOTE START / STOP (DRY CONTACT C.)	T3	1	(+) POSITIVE	NO VOLTAGE	<p>NOTE: USE ONLY DRY CONTACT FOR REMOTE S/S WHEN USING 4-20mA INPUT</p> <p>OPEN CIRCUIT IMPEDANCE MUST BE GREATER THAN 50K OHM</p>
	T3	2	(-) NEGATIVE		
INPUT: REMOTE START / STOP (WET CONTACT C.)	T3	2	(+) POSITIVE	6 TO 30 VOLT DC 1 AMP MAX.	<p>EXTERNAL DEVICE 6 TO 30V DC</p>
	T3	3	(-) NEGATIVE		
OUTPUT: 4-20 mA	T6	2	(+) POSITIVE	120 OHM RESISTANCE ACTIVE LOOP	<p>4-20mA RECEIVER 600 OHM LOAD MAX.</p>
	T6	1	(-) NEGATIVE		
OUTPUT: RELAY, 3 AMP	T7	1	NORM. CLOSED	Form C 3 AMP MAX AT 250 VAC, 3 AMP MAX AT 30 VOLT DC	<p>SWITCH LOAD 3 AMP MAX @ 250V AC 3 AMP MAX @ 30V DC</p>
	T7	2	COMMON		
	T7	3	NORM. OPEN		
OUTPUT: OPEN COLLECTOR MOTOR ACTIVE	T1	2	SIGNAL	5 TO 24 VDC	<p>CLOSED WHILE MOTOR IS ENERGIZED</p> <p>4.7K OHM</p> <p>SIGNAL OUT</p> <p>NEGATIVE (-)</p>
	T1	3	COMMON		
OUTPUT: MOTOR ACTIVE (CONTACT CLOSURE)	T8	1	NORM. CLOSED	Form C 1 AMP MAX AT 125 VAC, 0.8 AMP MAX AT 30 VOLT DC	<p>SWITCH LOAD 1 AMP MAX @ 125V AC 0.8 AMP MAX @ 30V DC</p>
	T8	2	COMMON		
	T8	3	NORM. OPEN		
INPUT: POWER	T11	1	GROUND	115V OR 230V AC MANUAL SWITCH 50 / 60 HZ 100W	<p>AC VOLTAGE</p> <p>LINE NEUTRAL (COMMON) GROUND</p> <p>POWER</p> <p>SWITCH FROM S1 115V TO 230V</p>
	T11	2	NEUTRAL		
	T11	3	LINE (HOT)		
FUSE	F1	N/A	5 AMP	5A SLOW BLOW (20 X 5MM)	

## 6.0 How to Operate Chem-Pro® - Control Pad

 **MODE**

**Press and Release while pump is stopped**  
To select Run Mode

- Mode 1: Manual
- Mode 2: 4-20mA input
- Mode 3: Frequency input
- Mode 4: Pulse / Batch

**Press and Hold while pump is stopped**  
To configure selected Mode

- Mode 0: Setup
- Mode 1: Manual
- Mode 2: 4-20mA input
- Mode 3: Frequency input
- Mode 4: Pulse / Batch

**Press and Release while pump is running**  
To display pump Speed or Flow Rate (if configured)

- Displays: Motor Speed
- Displays: Flow Rate



 **Press and release**  
To prime pump (60 seconds)

 **Press and release**  
Press UP arrow to increase pump speed (output) in Manual Operation.  
To increase value while in programming mode.

 **Press and release**  
Press DOWN arrow to decrease pump speed (output) in Manual Operation.  
To decrease value while in programming mode.

 **Press and release**  
To Stop pump at any time.

**Press and release**  
To Start pump.  
To begin listening (reacting) to external signal, such as Remote Start/Stop.

 **Press and hold**  
To enter programming mode.

- Remote Start/Stop setup
- FVS (flow verification sensor) setup

**Press and release**  
To save setting while in programming mode.  
To move to **next** selection while in programming mode.

**Time-out** - Chem-Pro® pumps have a time-out setting of approximately 20 seconds while in configuration menu. If built-in timer exceeds 20 seconds without a button being pressed, then pump will exit configuration menu. Changes will automatically be saved if programming mode is allowed to Time-Out.

## 6.1 Mode Descriptions

### Mode 0 - Setup

Press and Hold while pump is stopped to configure:

- Remote Start / Stop
- DFD (Diaphragm Failure Detection) sensitivity
- FVS (Flow Verification Sensor) time delay - requires sensor
- 4-20 mA output, available on certain models
- COMM (if comm module is installed, such as, Profibus, Profinet, Modbus, Modbus TCP, & Industrial Ethernet)  
*Instructions for Communication board extends scope of this manual.  
For more information, please see instructions that accompanied Communications board hardware. This is an optional item.*
- RATE (displays pump output flow rate)

Mode 0



### Mode 1 - Manual

Run pump locally by selecting pump speed (0.5 - 100%).

- Control speed by using up or down arrows after start button is pressed.
- Control speed by entering Mode 1 setup and selecting desired pump speed (0.5 - 100%)

Mode 1

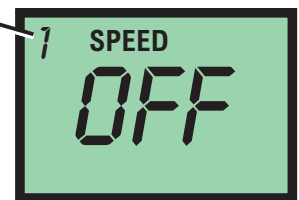

### Mode 2 - 4-20 mA Input Signal

Run pump remotely via external 4-20 mA signal.

- Press and Hold "MODE" button with Mode 2 selected to configure settings.
- Select Mode 2 and press START button to allow pump to be controlled by external 4-20mA signal.

Mode 2

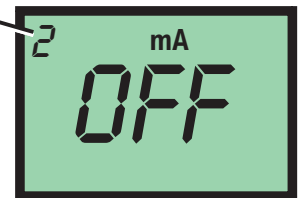

### Mode 3 - Frequency (Hz) Input Signal

Run pump remotely via external high frequency (Hz) signal.

- Press and Hold "MODE" button with Mode 3 selected to configure settings.
- Select Mode 3 and press START button to allow pump to be controlled by external frequency (Hz) signal.

Mode 3

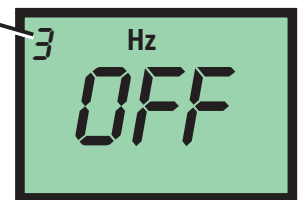

### Mode 4 - Pulse Batch Input Signal (low speed pulse)

Run pump remotely via external low speed pulse signal.

- Press and Hold "MODE" button with Mode 4 selected to configure settings.
- Select Mode 4 and press START button to allow pump to be controlled by external low speed pulse signal.

Mode 4

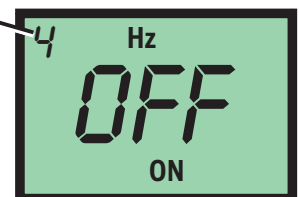

## 7.0 Mode 0 - Set Remote Start / Stop

Used to remotely start and stop pump using a dry contact closure signal.  
When activated; CLOSE = START and OPEN = STOP.

Set to NO = Remote Start / Stop is disabled  
Set to Yes = Remote Start / Stop is enabled

Can be used with external foot pedal, PLC, contact closure or other similar external devices.

Default setting = No (disabled)

### Step 1

Ensure pump is stopped and LCD reads "OFF."

Note: Mode cannot be changed while pump is in running.

Press and release STOP button if pump is running.

Press and release MODE button multiple times until Mode 0 is selected.

Mode 0



### Step 2

With Mode 0 selected, press and hold MODE button until 'Remote' icon begins flashing.

Default setting 'NO' will also be visible when entering remote start / stop setup.

Note: If 'YES' had been selected previously, then 'YES' will be displayed on screen.

Mode 0

Remote Icon

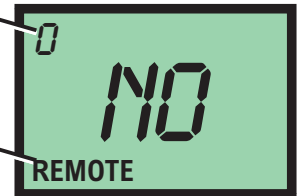

### Step 3

Press and release DOWN arrow to change setting to 'YES.'

To change setting back to 'NO' press and release UP arrow.

Mode 0



### Step 4

After you've made your selection, press and release MODE button. This saves your setting.

You can now modify other settings in Mode 0 or you can exit Setup by pressing and holding MODE button for a few seconds until you return to Run screen.

Mode 0



Running pump with Remote Start / Stop enabled, 'REMOTE' icon will always be visible on lower left side of screen. Pump will display 'STBY' (standby) if pump is in stop mode via contact closure signal. **Please use caution in this mode, pump can start at anytime. If you must perform maintenance to pump, press and release STOP button.**

## 7.1 Mode 0 - Set DFD Sensitivity

Chem-Pro pump is equipped with a Diaphragm Failure Detection (DFD) system which is designed to stop pump in event diaphragm should rupture and chemical enters pump head. This system is capable of detection presence of a large number of chemicals including Sodium Hypochlorite (chlorine), Hydrochloric (muriatic) Acid, Sodium Hydroxide, and many others.

Minimum and Maximum setting = 75 % to 100%

Default Setting = 75% (75% is recommended; triggers with most water treatment chemicals without false alarms)

Important: 100% sensitivity setting may trigger false alarm by washdown or rain. 100% setting is only recommended when absolutely necessary.

### Step 1

Ensure pump is stopped and LCD reads "OFF."

Note: Mode cannot be changed while pump is in running.

Press and release STOP button if pump is running.

Press and release MODE button multiple times until Mode 0 is selected.

Mode 0



### Step 2

With Mode 0 selected, press and hold MODE button until 'Remote' icon begins flashing.

This indicates that you've entered Setup menu.

Mode 0

Remote  
Icon



### Step 3

Press and release MODE button to scroll through menu until you see DFD icon.

If you pass DFD screen, continue to press and release MODE button until TFD icon appears.

Mode 0



### Step 4

DFD icon will appear for 1 second, followed by numbers.

Numbers indicate sensitivity value of DFD.

Press and release UP arrow button to increase sensitivity value.

Press and release DOWN arrow button to decrease sensitivity value.

Mode 0



### Step 5

After you've made your selection, press and release MODE button. This saves your setting.

You can now modify other settings in Mode 0 or you can exit Setup by; press and hold MODE button for a few seconds until you return to Run screen.

Mode 0



## 7.2 Mode 0 - Set FVS (flow verification system)

Flow verification sensor sold separately.

Flow verification system is designed to stop pump in an event sensor does not detect flow during pump operation. Indicating an empty chemical tank, clogged injection fitting, loose tubing connection, etc.

To allow pump to clear any gasses that may have accumulated over time, an alarm delay time value from 1 to 255 seconds must be programmed.

Note: An alarm delay of 000 seconds disables FVS system.

### Step 1

Ensure pump is stopped and LCD reads "OFF."

Note: Mode cannot be changed while pump is in running.

Press and release STOP button if pump is running.

Press and release MODE button multiple times until Mode 0 is selected.

Mode 0



### Step 2

With Mode 0 selected, press and hold MODE button until 'Remote' icon begins flashing.

This indicates that you've entered Setup menu.

Mode 0

Remote  
Icon



### Step 3

Press and release MODE button to scroll through menu until you see FVS icon.

If you pass FVS screen, continue to press and release MODE button until FVS icon appears.

Mode 0



### Step 4

FVS icon will appear for 1 second, followed by numbers.

These numbers indicate delay time setting for FVS.

Select a delay time in seconds. Delay time is amount of time pump will wait to receive a pulse from sensor until an alarm it triggered.

A delay time of 00 deactivates FVS feature.

Mode 0



### Step 5

After you've made your selection, press and release MODE button. This saves your setting.

You can now modify other settings in Mode 0 or you can exit Setup by; press and hold MODE button for a few seconds until you return to Run screen.

Mode 0



**Time-out** - Chem-Pro® pumps have a time-out setting of approximately 20 seconds while in configuration menu. If built-in timer exceeds 20 seconds without a button being pressed, then pump will exit configuration menu. Changes will automatically be saved if programming mode is allowed to Time-Out.

## 7.2 Mode 0 - Set FVS (flow verification system) - Continued

Flow Verification Sensor is designed to give you two installation options.

Sensor can be installed:

- Directly onto pump head of Chem-Pro® pump, discharge side.
- Anywhere on discharge side of Chem-Pro® pump.

Wiring for sensor can be connected directly to a Chem-Pro® pump. Pump will stop pumping if sensor detects no flow. A relay will then close allowing for remote alarm indication or initiation of a back-up pump. **Install FVS Flow Sensor** - Flow Verification Sensor should be installed on inlet (suction) side of pump tube.

When installing directly onto pump 3/8" tube discharge fitting:

Sensor includes a PVC tubing insert, located inside sensors female thread connection, that is designed to seal sensor onto pump tube adapter. Thread sensor onto pump tube until tubing insert is snug against pump tube fitting - do not over-tighten.

Sensor Model Number	Published Flow Range	Actual Working Range with Chem-Pro® Pump
	ML/Min	ML/Min
FV-100	30-300	30-200
FV-200	100-1000	50-900
FV-300	200-2000	100-1800
FV-400	300-3000	300-3000
FV-500	500-5000	500-5000
FV-600	700-7000	700-7000

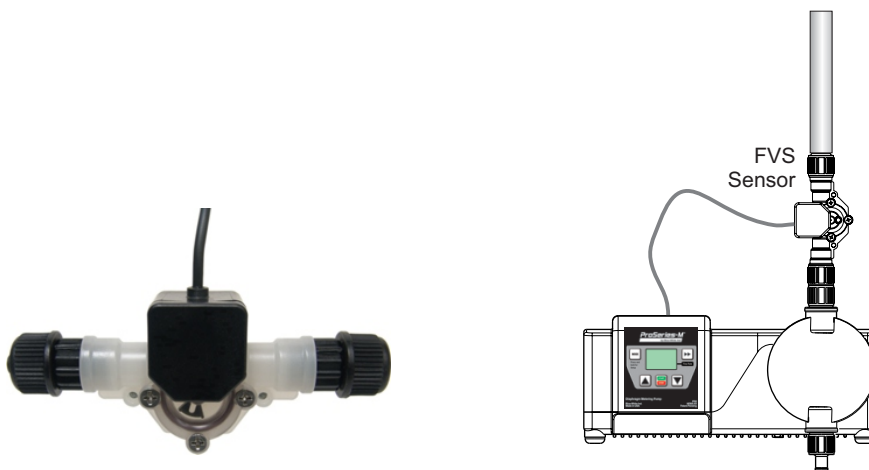

**Confirm FVS flow range** - Flow Verification Sensor (FVS) will only function within its operating range. See chart for available ranges.

NOTE: If pump output is less than 30 ml/min, sensor will not detect chemical and a signal will not be sent to pump, resulting in an alarm condition.

NOTE: For low viscosity (water-like) fluids only. Consult factory if attempting to use with viscous fluids.

## 7.3 Mode 0 - Set 4-20mA Output

Sends a configurable 4-20 mA signal, based on pump rotor speed, to an external device. This feature can be used to control other pumps (in sync / proportionally), data logging systems, and other external devices for plant automation.

Default setting: Minimum Speed = 4 mA signal output  
Maximum Speed = 20 mA signal output

Set to NO = disabled  
Set to Yes = enabled

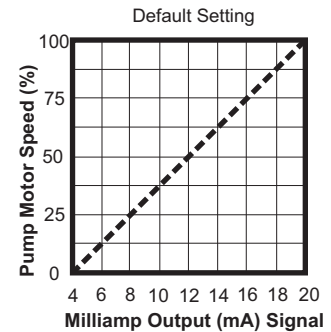

### Step 1

Ensure pump is stopped and LCD reads "OFF."  
Note: Mode cannot be changed while pump is in running.  
Press and release STOP button if pump is running.  
Press and release MODE button multiple times until Mode 0 is selected.

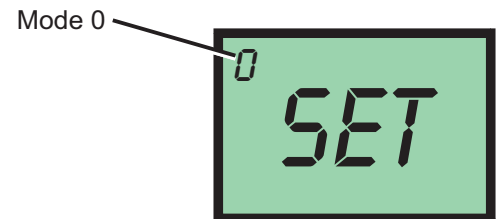

### Step 2

With Mode 0 selected, press and hold MODE button until 'Remote' icon begins flashing.  
This indicates that you've entered Setup menu.

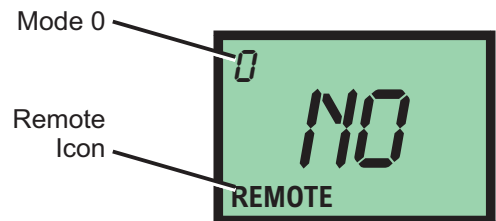

### Step 3

Press and release MODE button to scroll through menu until you see 4-20 mA icon.  
To select Yes, press and release DOWN arrow.  
To select No, press and release UP arrow.  
To begin configuring values, select Yes.  
Then press and release MODE button.

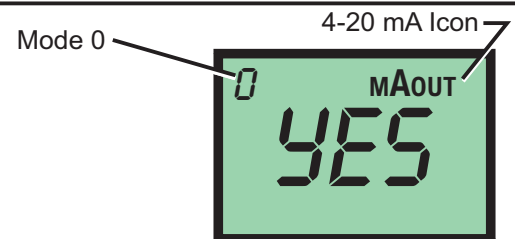

### Step 4

**Minimum pump speed** will be displayed.  
To increase value, press and release UP arrow.  
To decrease value, press and release DOWN arrow.  
To save value, press and release MODE button.

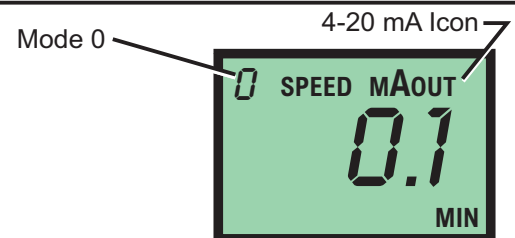

**Time-out** - Chem-Pro® pumps have a time-out setting of approximately 20 seconds while in configuration menu. If built-in timer exceeds 20 seconds without a button being pressed, then pump will exit configuration menu. Changes will automatically be saved if programming mode is allowed to Time-Out.



### 7.3 Mode 0 - Set 4-20mA Output - Continued

#### Step 5

**Output signal at minimum speed** will now be displayed.  
 To increase value, press and release UP arrow.  
 To decrease value, press and release DOWN arrow.  
 To save value, press and release MODE button.

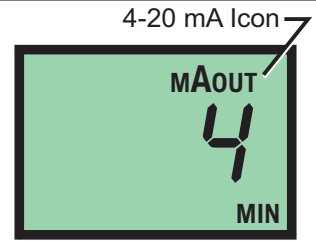

#### Step 6

**Maximum pump speed** will be displayed.  
 To increase value, press and release UP arrow.  
 To decrease value, press and release DOWN arrow.  
 To save value, press and release MODE button.

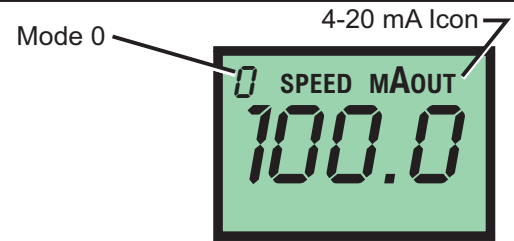

#### Step 7

**Output signal at maximum speed** will now be displayed.  
 To increase value, press and release UP arrow.  
 To decrease value, press and release DOWN arrow.  
 To save value, press and release MODE button.

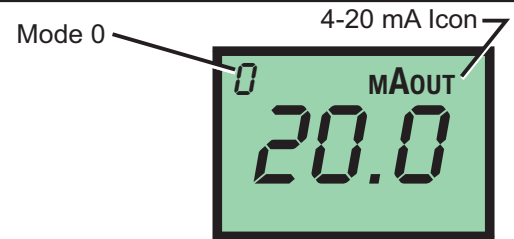

#### Step 8

You can now modify other settings in Mode 0 or you can exit Setup by; press and hold MODE button for a few seconds until you return to Run screen.

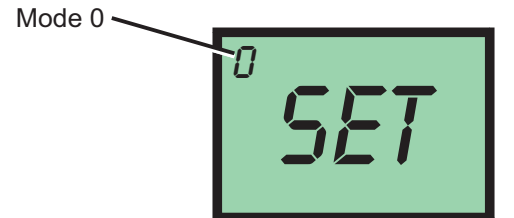

#### Example 1

0% Pump Output = 4 mA  
 100 % Pump Output = 20 mA

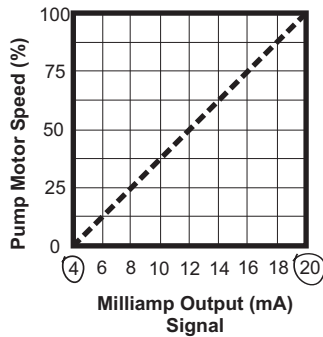

#### Example 2

0% Pump Output = 4 mA  
 50% Pump Output = 16 mA

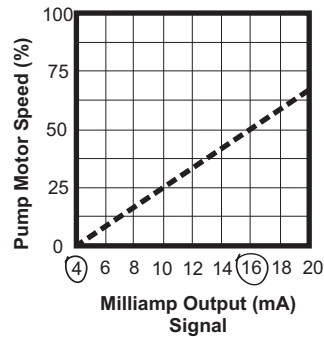

## 7.4 Mode 0 - Set Flow Rate Display

Display pump output Flow Rate. Default setting: mL/m (Milliliter per minute)

Available settings: none, mL/m, Oz/m, L/h, G/h

Before you begin configuring your Flow Rate, please perform a volumetric test on your pump. Please see section 13.0 Volumetric Test - Calibration

Log your Flow Rate using Milliliters Per Minute here \_\_\_\_\_ mL/m.

### Step 1

Ensure pump is stopped and LCD reads "OFF."

Note: Mode cannot be changed while pump is in running.

Press and release STOP button if pump is running.

Press and release MODE button multiple times until Mode 0 is selected.

Mode 0



### Step 2

With Mode 0 selected, press and hold MODE button until 'Remote' icon begins flashing.

This indicates that you've entered Setup menu.

Mode 0

Remote  
Icon



### Step 3

Press and release MODE button to scroll through menu until you see RATE display for 2 seconds.

Arrow pointing at Flow Rate will begin flashing.

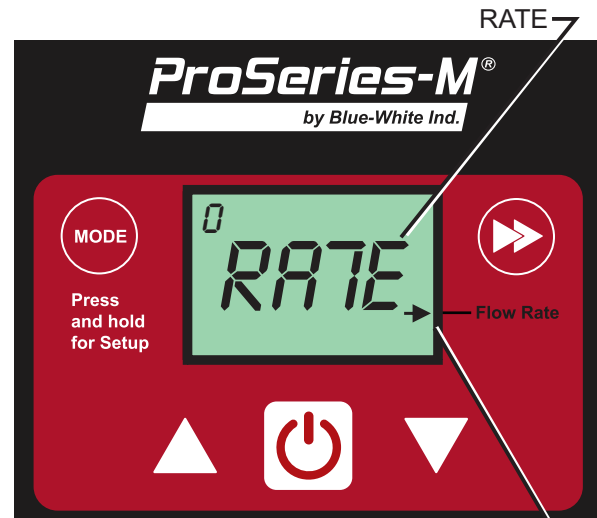

Flow Rate Arrow

### Step 4

Press and release UP button or DOWN button to scroll through Flow Rate units.

Available Flow Rate units:

- None, mL/m, Oz/m, L/h, G/h

Select desired Flow Rate unit. Then press and release MODE button to save selection.

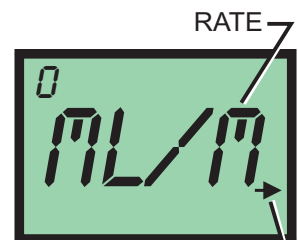

Flow Rate Arrow

## 7.4 Mode 0 - Set Flow Rate Display - Continued

### Step 5

LCD will flash "MAX" then "FLO" then "mL/m" (or your selected Flow Rate unit), each for 2 seconds.



### Step 6

LCD will show four digits (default is 2650 mL/m).  
 Use this screen to input maximum Flow Rate for your pump in Milliliters Per Minute.  
 To increase value, press and release UP arrow.  
 To decrease value, press and release DOWN arrow.  
 To save value, press and release MODE button.



Default: 2650 mL/m

Important Note: At this step, you are going to input your pumps max Flow Rate in mL/m. While pump is in normal operation, Flow Rate unit you've selected in Step 4 will be displayed on LCD.

### Step 7

You can now modify other settings in Mode 0 or you can exit Setup by; press and hold MODE button for a few seconds until you return to Run screen.

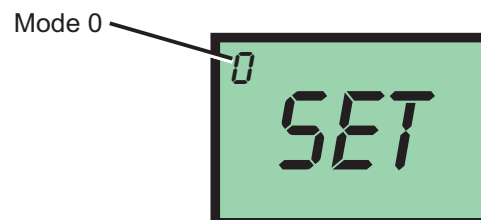

## 7.4.1 Operation Screens Displaying Flow Rate

### Runtime Screen Shot 1

While pump is running, press and release MODE button repeatedly until Flow Rate arrow is displayed pointing at Flow Rate.

LCD will automatically scroll (loop) between actual Flow Rate and units of measure.

Flow value displayed for 4 seconds.  
 Units of measure displayed for 2.5 seconds.

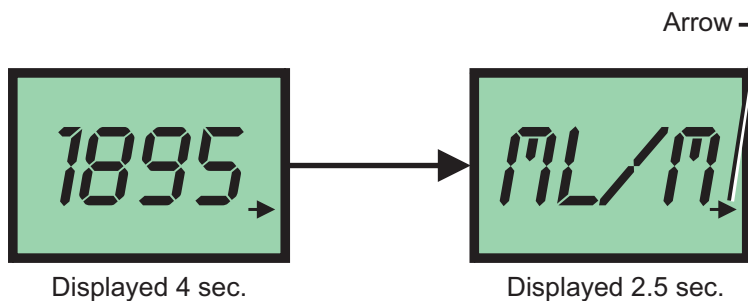

## 8.0 Mode 1 - Manual Operation

Used to manually control speed of pump.

Use UP and DOWN arrows to adjust speed while pump is running.

To select exact run speed, follow steps below.

### Step 1

Ensure pump is stopped and LCD reads "OFF."

Note: Mode cannot be changed while pump is in running.

Press and release STOP button if pump is running.

Press and release MODE button multiple times until Mode 1 is selected.

Mode 1

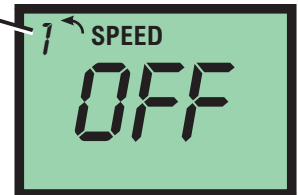

### Step 2

With Mode 1 selected, press and hold MODE button until 'Speed' icon begins flashing.

This indicates that you've entered Setup menu.

Mode 1



### Step 3

**Current pump speed** will be displayed.

To increase value, press and release UP arrow.

To decrease value, press and release DOWN arrow.

To save value, press and hold MODE button until 'Speed' icon stop flashing.

Mode 1



### Step 4

Pump will now operate at your pre-configured speed.

Press and release START button to start pump.

Press and release STOP button at anytime to stop pump.

Mode 1

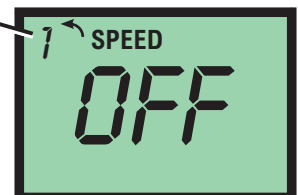

With pump operating in manual mode (Mode 1), pump speed can be changed at anytime by using UP or DOWN arrows during operation.

## 8.1 Mode 1 - Manual Operation Screen Shots

### Runtime Screen Shot 1

Display motor speed percentage.  
Pump Running in Manual Operation

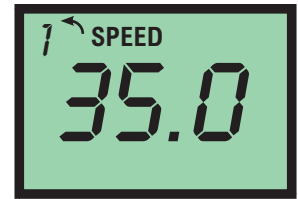

### Runtime Screen Shot 2

Display 4-20mA output (select models only)  
Press and release MODE button to view mA output value  
in real-time.

**Please note:** 4-20mA output is only available on select models. If included in  
your model; 4-20mA output must be enabled in Mode 0 (see page 16).

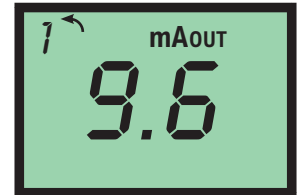

### Runtime Screen Shot 3

Display motor speed percentage.  
Press and release MODE button to view percentage of  
motor speed.

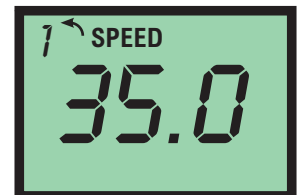

## 9.0 Mode 2 - 4-20mA Input Operation

Used to remotely control pump with an incoming 4-20 mA signal.

Default setting: 4 mA signal = 0.1% motor speed  
20 mA signal = 100.0% motor speed

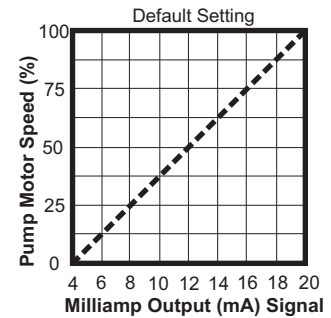

### Step 1

Ensure pump is stopped and LCD reads "OFF."

Note: Mode cannot be changed while pump is in running.

Press and release STOP button if pump is running.

Press and release MODE button multiple times until Mode 2 is selected.

Mode 2

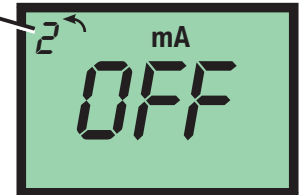

### Step 2

With Mode 2 selected, press and hold MODE button until 'Speed' icon begins flashing.

This indicates that you've entered Setup menu.

Mode 2

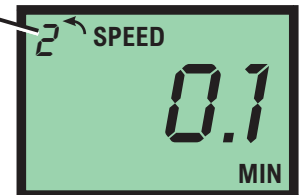

### Step 3

**Minimum pump speed** will be displayed.

To increase value, press and release UP arrow.

To decrease value, press and release DOWN arrow.

To save value, press and release MODE button.

Mode 2

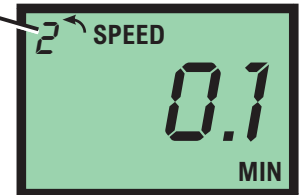

### Step 4

**mA value linked to minimum pump speed** will be displayed.

To increase value, press and release UP arrow.

To decrease value, press and release DOWN arrow.

To save value, press and release MODE button.

Mode 2

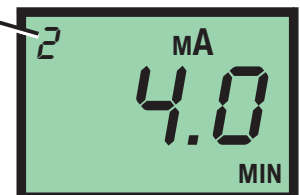

### Step 5

**Maximum pump speed** will be displayed.

To increase value, press and release UP arrow.

To decrease value, press and release DOWN arrow.

To save value, press and release MODE button.

Mode 2



**Time-out** - Chem-Pro® pumps have a time-out setting of approximately 20 seconds while in configuration menu. If built-in timer exceeds 20 seconds without a button being pressed, then pump will exit configuration menu. Changes will automatically be saved if programming mode is allowed to Time-Out.

## 9.0 Mode 2 - 4-20mA Input Operation - Continued

### Step 6

**mA value linked to minimum pump speed** will now be displayed.

To increase value, press and release UP arrow.

To decrease value, press and release DOWN arrow.

To save value, press and release MODE button.

Mode 2

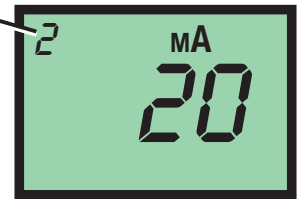

### Step 7

To exit Setup, press and hold MODE button for a few seconds until you return to Run screen.

Mode 2

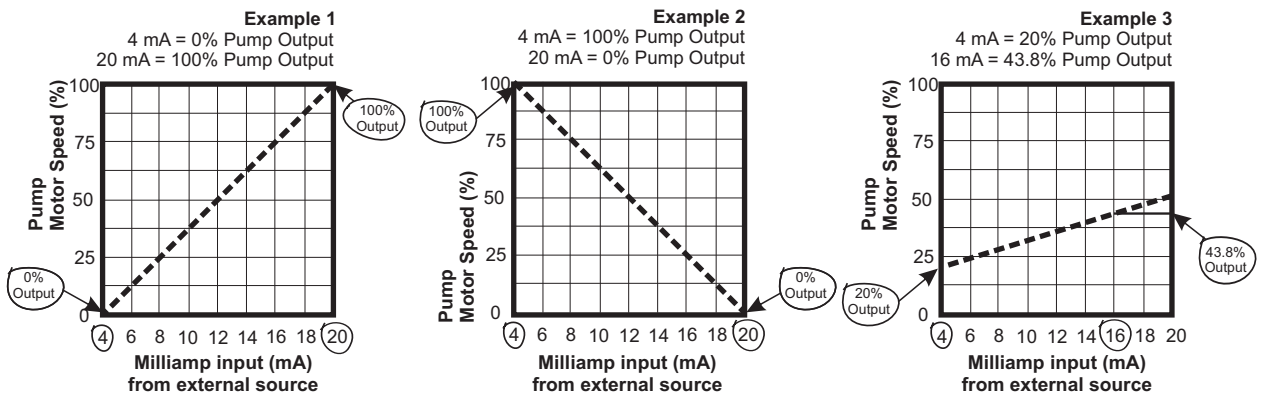
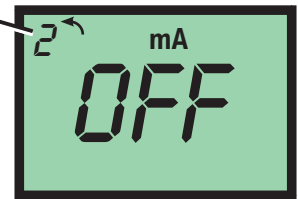

## 9.1 Mode 2 - 4-20mA Input Screen Shots

### Runtime Screen Shot 1

Display **motor speed percentage**.  
Pump Running in 4-20mA Input Operation

Mode 2



### Runtime Screen Shot 2

Display current 4-20mA input signal  
Press and release MODE button to view **mA input** value in real-time.

Mode 2

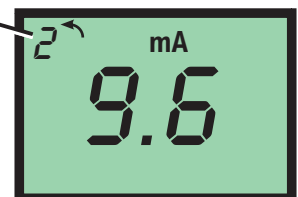

### Runtime Screen Shot 3

Press and release MODE button again to view **mA output** value in real-time (available on select models only).  
Press and release MODE button again to view **motor speed percentage**, as in Screen Shot 1.

Mode 2

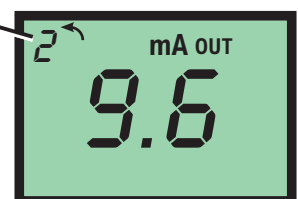

## 10.0 Mode 3 - Frequency Input (Hz) Operation

Used to remotely control pump with an incoming high speed frequency signal. Typically used with flow meters or other external devices.

Default setting: 0 Frequency (Hz) = 0% motor speed  
1000 Frequency (Hz) = 100% motor speed

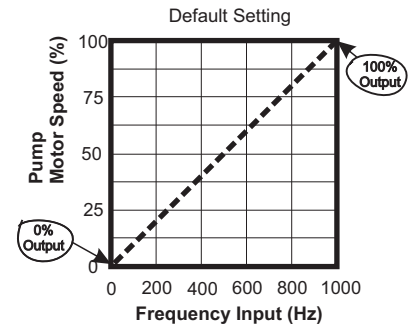

### Step 1

Ensure pump is stopped and LCD reads "OFF."

Note: Mode cannot be changed while pump is in running.

Press and release STOP button if pump is running.

Press and release MODE button multiple times until Mode 3 is selected.

Mode 3

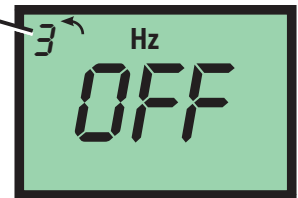

### Step 2

With Mode 3 selected, press and hold MODE button until 'Speed' icon begins flashing.

This indicates that you've entered Setup menu.

Mode 3

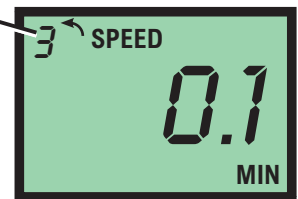

### Step 3

**Pump speed at minimum Frequency** will be displayed.

To increase value, press and release UP arrow.

To decrease value, press and release DOWN arrow.

To save value, press and release MODE button.

Mode 3

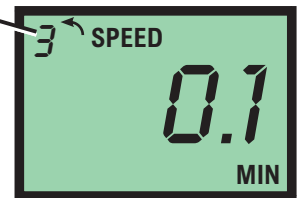

### Step 4

**Minimum Frequency (Hz) value** will be displayed.

To increase value, press and release UP arrow.

To decrease value, press and release DOWN arrow.

To save value, press and release MODE button.

Mode 3

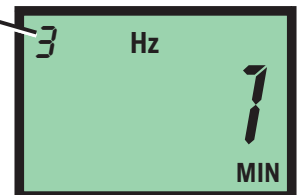

**Time-out** - Chem-Pro® pumps have a time-out setting of approximately 20 seconds while in configuration menu. If built-in timer exceeds 20 seconds without a button being pressed, then pump will exit configuration menu. Changes will automatically be saved if programming mode is allowed to Time-Out.



### 10.0 Mode 3 - Frequency Input (Hz) Operation - Continued

**Step 5**

**Pump speed at maximum Frequency** will be displayed.

To increase value, press and release UP arrow.

To decrease value, press and release DOWN arrow.

To save value, press and release MODE button.

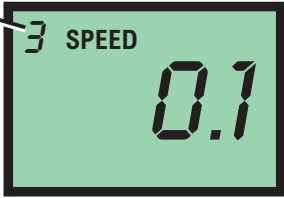

Mode 3

**Step 6**

**Maximum Frequency value** will now be displayed.

To increase value, press and release UP arrow.

To decrease value, press and release DOWN arrow.

To save value, press and release MODE button.



Mode 3

**Step 7**

To exit Setup, press and hold MODE button for a few seconds until you return to Run screen.



Mode 3

**Examples:**

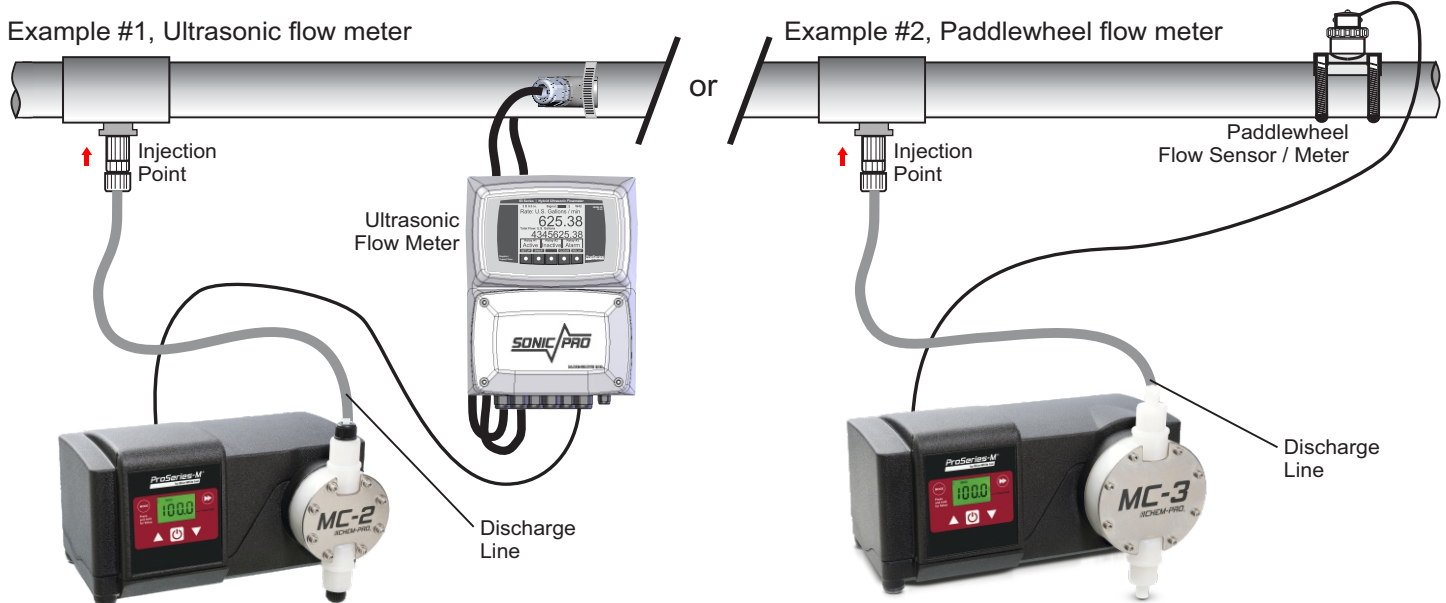
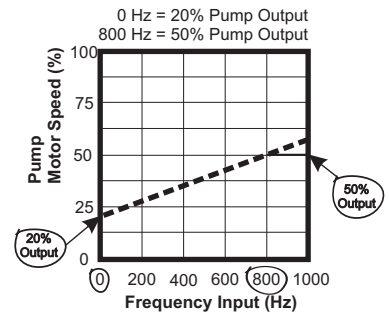
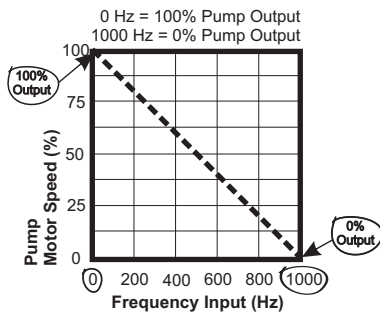
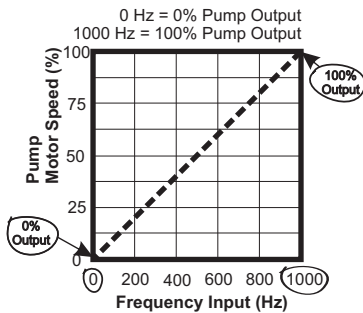

## 11.0 Mode 4 - Pulse Batch (low speed pulse) Operation

Used to remotely control pump with an incoming pulse signal. Can be used with an external foot pedal, a water meter, a PLC, contact closure, or other low speed pulse devices.

Default setting: 1 Pulse = 100% motor speed for 2.5 seconds

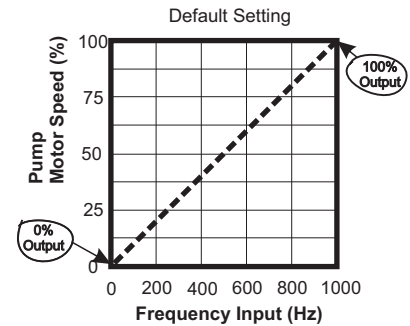

### Step 1

Ensure pump is stopped and LCD reads "OFF."

Note: Mode cannot be changed while pump is in running.

Press and release STOP button if pump is running.

Press and release MODE button multiple times until Mode 2 is selected.

Mode 4

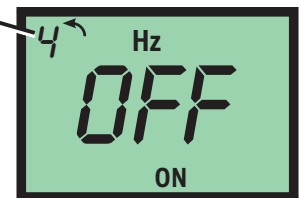

### Step 2

With Mode 4 selected, press and hold MODE button until 'On' icon begins flashing.

This indicates that you've entered Setup menu.

Mode 4



### Step 3

**Pump on-time** will be displayed in either MIN (minutes) or SEC (seconds).

To increase value, press and release UP arrow.

To decrease value, press and release DOWN arrow.

To save value, press and release MODE button.

Mode 4



### Step 4

**MIN (minutes) or SEC (seconds)** will be displayed in lower right hand corner. This value will be linked to Pump on-time number in previous screen.

To change this setting, press and release either UP arrow or DOWN arrow.

To save value, press and release MODE button.

Mode 4

MIN or SEC

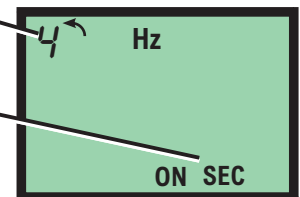

**Time-out** - Chem-Pro® pumps have a time-out setting of approximately 20 seconds while in configuration menu. If built-in timer exceeds 20 seconds without a button being pressed, then pump will exit configuration menu. Changes will automatically be saved if programming mode is allowed to Time-Out.

## 11.0 Mode 4 - Pulse Batch (low speed pulse) Operation - Continued

### Step 5

**Number of pulses to trigger pump start** will be displayed.  
To increase value, press and release UP arrow.  
To decrease value, press and release DOWN arrow.  
To save value, press and release MODE button.

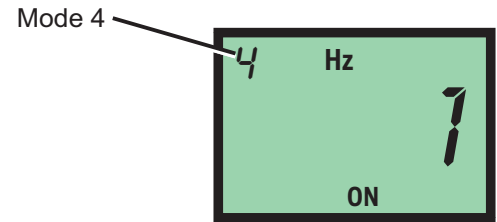

### Step 6

**Pump speed during on-time** will now be displayed.  
Pump will run at this speed after selected number of pulses is reached from previous menu.  
To increase value, press and release UP arrow.  
To decrease value, press and release DOWN arrow.  
To save value, press and release MODE button.

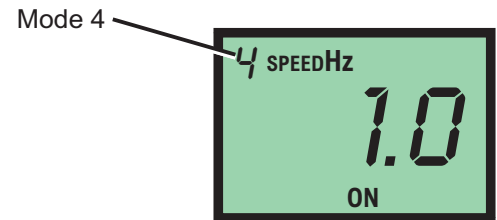

### Step 7

To exit Setup, press and hold MODE button for a few seconds until you return to Run screen.

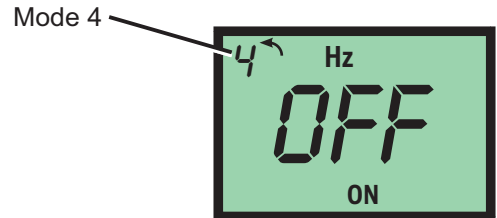

## 11.1 Mode 4 - Pulse Batch Operation Screen Shots

### Runtime Screen Shot 1

Display **motor speed percentage**.  
Pump Running in Pulse Batch Operation

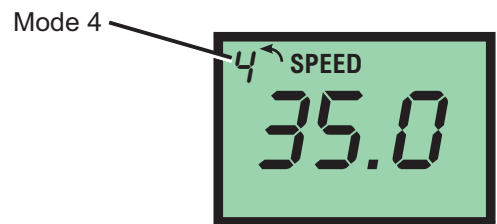

### Runtime Screen Shot 2

Display current number of pulses received  
Press and release MODE button to view number of **pulses received** in real-time.

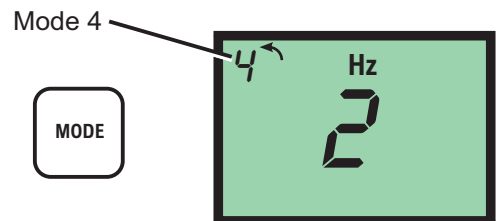

### Runtime Screen Shot 3

Press and release MODE button again to view **mA output** value in real-time (available on select models only).  
Press and release MODE button again to view **motor speed percentage**, as in Screen Shot 1.

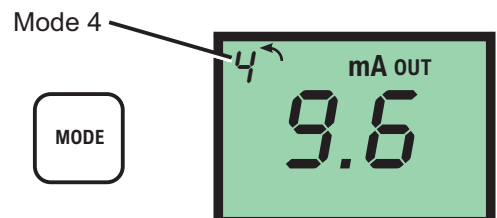

## 12.0 Alarm Relay

Pump has a built in 3 amp alarm output relay. Relay is pre-configured to energize on diaphragm failure detection (DFD) and on Flow Verification Sensor (FVS).

A Flow Verification Sensor must be installed and configured for relay to trigger on no-flow conditions. See page 9 for wiring details.

## 13.0 Volumetric Test - Calibration

This volumetric test will take into account individual installation factors such as line pressure, fluid viscosity, suction lift, etc. This test is most accurate for measuring injector's output in an individual installation.

1. Be sure Injection Fitting and Footvalve / Strainer are clean and working properly.
2. Fill a large graduated cylinder with solution to be injected.
3. With pump installed under normal operating conditions, place suction tubing with Footvalve / Strainer installed in graduated cylinder.
4. Push 3/8" tubing onto priming valve. Place other side of 3/8" tubing in solution tank. Make sure priming valve is closed by turning valve to right.
5. Run pump until all air is removed from suction line and solution enters discharge tubing.  
If pump does not easily prime, loosen priming valve 1 - 2 turns counter clock wise. Once air is removed close priming valve.
6. Remove suction tubing from graduated cylinder and refill graduated cylinder if necessary. Note amount of solution in graduated cylinder.
7. Place suction tubing with Footvalve / Strainer installed back into graduated cylinder.
8. Run injector for a measured amount of time. A longer testing time will produce more accurate results.
9. Remove suction tubing from graduated cylinder. Measure amount of chemical injected.

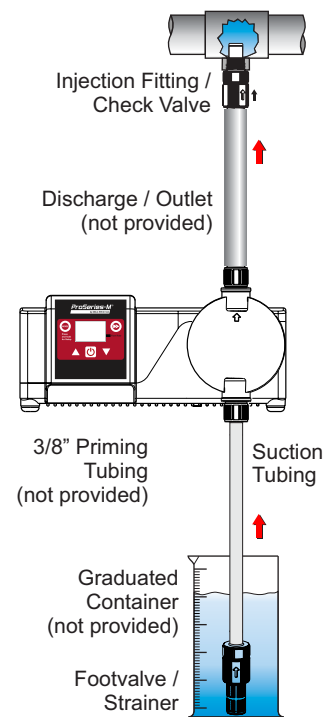

### Example:

During your 1 minute calibration period, say Chem-Pro pumped 1000 Milliliters in 1 minute.

$$1 \text{ US Gallon} = 3.785 \text{ Liters} = 3785 \text{ Milliliters}$$



$$\left( \frac{1000 \text{ ML/Min}}{3785} \right) 60 = 15.85 \text{ GPH (US gallons per hour)}$$

Minutes per hour

Milliliters in a US gallon

**Note:** All diagrams are strictly for guideline purposes only. Always consult an expert before installing pump into specialized systems. Pump should be **serviced by qualified persons only.**

## 14.0 Pump Maintenance

<b>CAUTION</b> 	Prior to service, pump clean water through pump and suction / discharge line to remove chemical.
<b>CAUTION</b> 	Always wear protective clothing, face shield, safety glasses and gloves when working on or near your metering pump. Additional precautions should be taken depending on solution being pumped. Refer to MSDS precautions from your solution supplier.

### 14.1 Routine Inspection and Maintenance

Pump requires very little maintenance. However, pump and all accessories should be checked weekly. This is especially important when pumping chemicals. Inspect all components for signs of leaking, swelling, cracking, discoloration or corrosion. Replace worn or damaged components immediately.

Cracking, crazing, discoloration during first week of operation are signs of severe chemical attack. If this occurs, immediately remove chemical from pump. Determine which parts are being attacked and replace them with parts that have been manufactured using more suitable materials. Manufacturer does not assume responsibility for damage to pump that has been caused by chemical attack.

Brush Kit Life Cycle over 3,000 hours of continuous use at max speed. A spare brush kit is located inside of pump housing.

### 14.2 Cleaning Pump

Pump will require occasional cleaning, especially Injection fitting, Footvalve / Strainer, and pump head valves. Frequency will depend on type and severity of service.

- ✓ Inspect and replace pump head valves as required.
- ✓ When changing diaphragm, pump head chamber and pump head cover should be wiped free of any dirt and debris. The pump stroke must be FORWARD when screwing in the diaphragm and BACKWARD when installing and tightening the pump head.
- ✓ Periodically clean injection / check valve assembly, especially when injecting fluids that calcify such as sodium hypochlorite. These lime deposits and other build ups can clog fitting, increase back pressure and interfere with check valve operation.
- ✓ Periodically clean suction strainer.
- ✓ Periodically inspect pump housing (enclosure) for chemical attack. Protect pump housing from continuous exposure to chemicals, such as drips or fumes from surrounding equipment and plumbing.

## 14.3 Motor Brush Replacement

Brushes wear differently on each side of motor. It is recommended to replace both brushes at the same time.

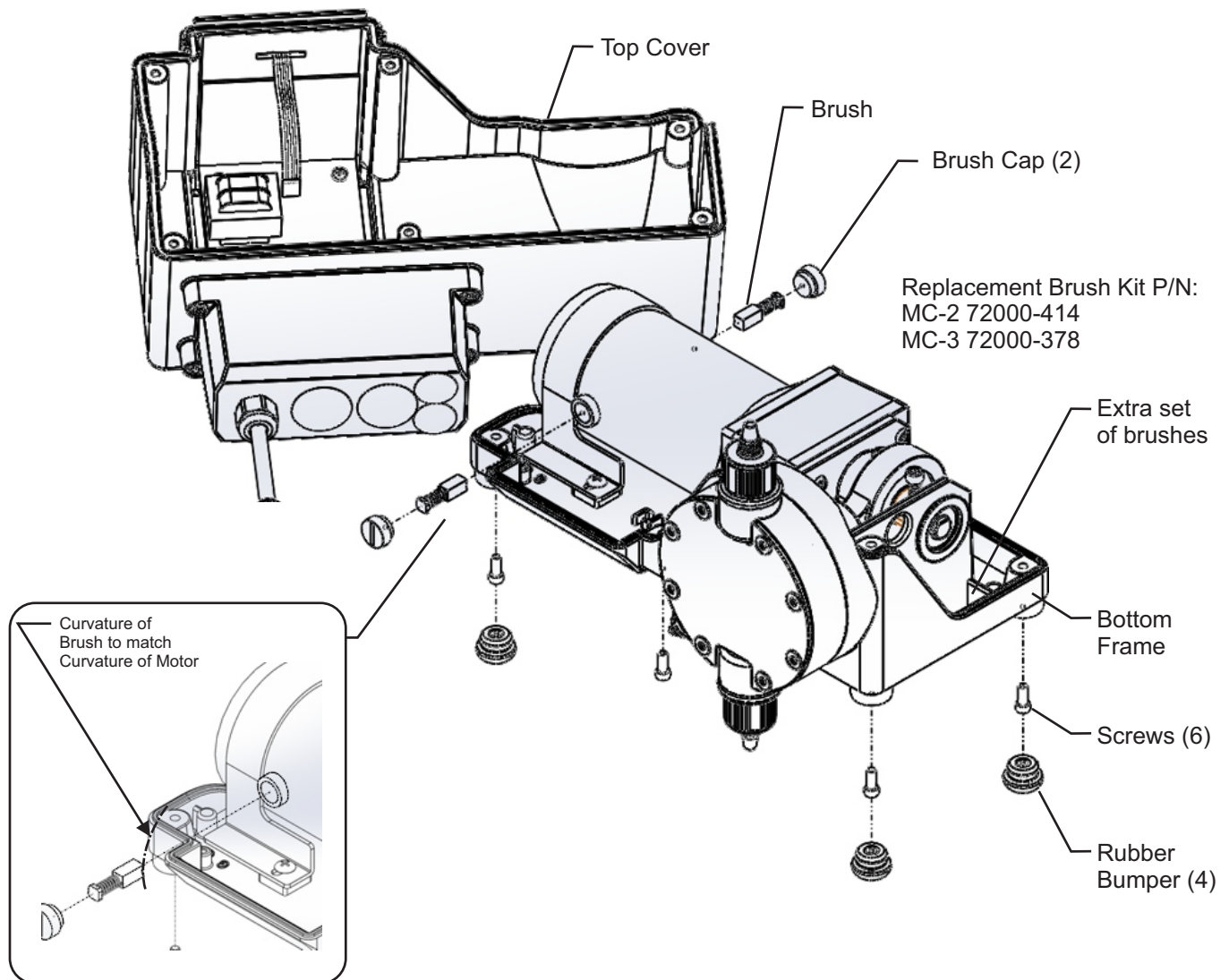

### Step 1

Remove 4 black rubber bumpers from bottom frame.

### Step 2

Remove 6 screws from underneath side of bottom frame.

### Step 4

Lift off top cover from bottom frame carefully. Place top cover close to bottom frame.

*Please Note:* Wires connecting top and bottom may become unplugged if pulled too far apart.

### Step 5

Unscrew and remove brush caps by turning counter-clockwise.

### Step 6

Remove used brushes and discard properly.

### Step 7

Insert new brushes. Be sure to install brushes to that curvature of brush is concentric to curvature of motor. Please note: One extra set of brushes are provided inside frame.

Intentionally left blank

## 15.0 Replacement Parts List

### 15.1 MC-2 Parts List

ITEM	PART NO.	DESCRIPTION	QTY REQ.
2	70004-109	COVER P/H, CM-2, SS	1
3	90011-149	SCREW 10X32 X 1.25	8
4	90011-094	WASHER #10 P/H SS	8
6	71010-446	P/HEAD MICRO MC-2 PVDF	1
	90002-273	P/HEAD SM MC-2 PVDF	
	90002-272	P/HEAD LG MC-2 PVDF	
7	70001-349	VALVE .5 M/NPT VIT	2
	70001-350	VALVE .5 M/NPT EP	
	70001-351	VALVE .5 F/NPT VIT	
	70001-352	VALVE .5 F/NPT EP	
	70001-347	VALVE .5 T-BARB VIT	
	70001-348	VALVE .5 T-BARB EP	
	70001-372	VALVE .375 TUBE VIT	
	70001-373	VALVE .375 TUBE EP	
	8	20000-194	
20000-195		KIT 4 EA. VALVE EP	
9	72000-551	MICRO DIAPHRAGM KIT	1
	72000-296	SMALL DIAPHRAGM KIT	
	72000-297	LARGE DIAPHRAGM KIT	
	72000-606	MICRO DIA KIT FLEX-A-PRENE	
	72000-607	SM DIA KIT FLEX-A-PRENE	
	72000-605	LG DIA KIT FLEX-A-PRENE	
11	71001-002	FRAME INSERT LG. W/SEAL	1
	71001-003	FRAME INSERT SM. W/SEAL	
13	90003-561	BUMPER FEET	4
14	90002-326	UV LCD CVR PLYCRB	1
16	71000-984	J-BOX KIT W/ 115V	1
	71010-032	J-BOX KIT W/ 220V	1
	71010-031	J-BOX KIT W/ 230V	1
	71010-033	J-BOX KIT W/ 240V	1
21	71000-575	FOOTVALVE .5 T CR VIT	1
	71000-447	FTVALVE .5 CR VT/AF NO SP	
	71000-325	FOOTVALVE .5 CR EP NO SP	
22	90008-043	CLAMP SS .5"	1

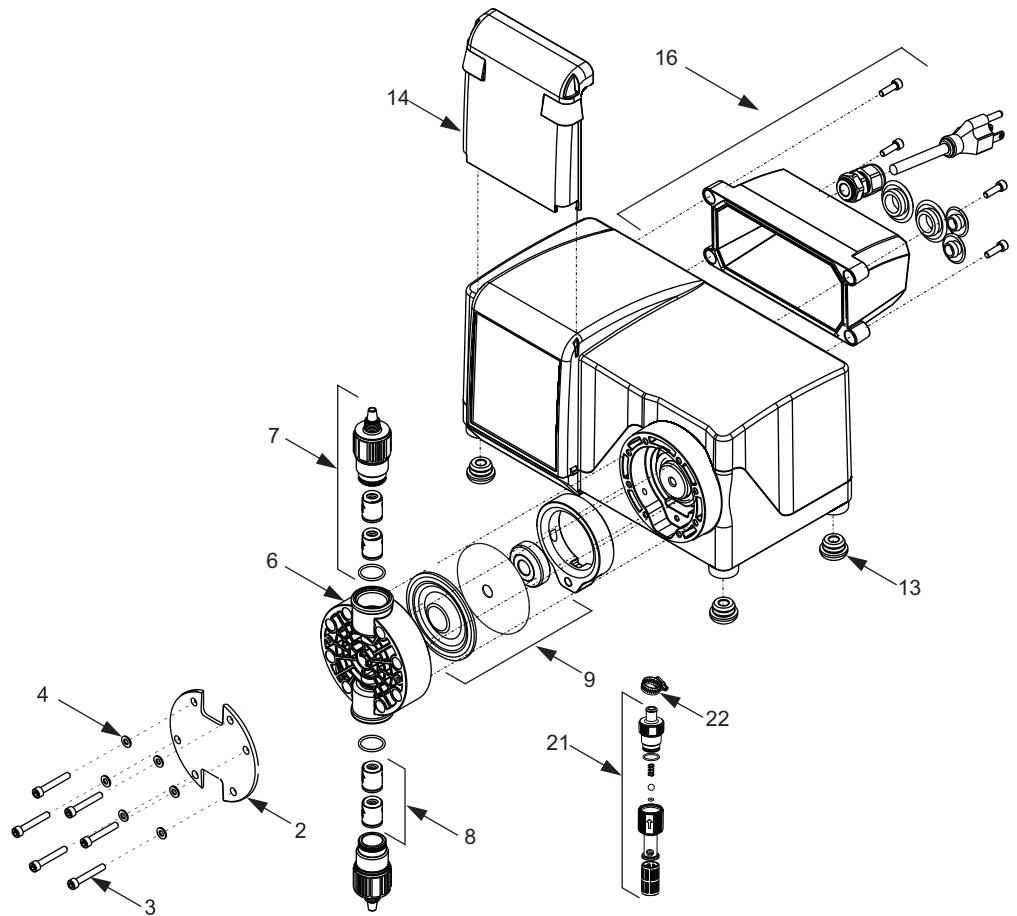



### 15.2 MC-3 Parts List

ITEM	PART NO.	DESCRIPTION	QTY REQ.
2	70004-110	COVER P/H, CM-3, SS	1
3	90011-149	SCREW 10X32 X 1.25	8
4	90011-094	WASHER #10 P/H SS	8
6	90002-258	P/HEAD LG C3 PVDF	1
7	70001-349	VALVE .5 M/NPT VIT	2
	70001-350	VALVE .5 M/NPT EP	
	70001-351	VALVE .5 F/NPT VIT	
	70001-352	VALVE .5 F/NPT EP	
	70001-347	VALVE .5 T-BARB VIT	
	70001-348	VALVE .5 T-BARB EP	
	8	20000-194	
20000-195	KIT 4 EA. VALVE EP		
9	72000-295	DIAPHRAGM KIT	1
	72000-604	DIAPHRAGM KIT FLEX-A-PRENE	
13	90003-561	BUMPER FEET	4
14	90002-326	UV LCD CVR PLYCRB	1
16	71000-984	J-BOX KIT W/ 115V	1
	71010-032	J-BOX KIT W/ 220V	
	71010-031	J-BOX KIT W/ 230V	
	71010-033	J-BOX KIT W/ 240V	
21	71000-575	FOOTVALVE .5 T CR VIT	1
	71000-447	FTVALVE .5 CR VIT/AF NO SP	
	71000-325	FOOTVALVE .5 CR EP NO SP	
22	90008-043	CLAMP SS .5"	1

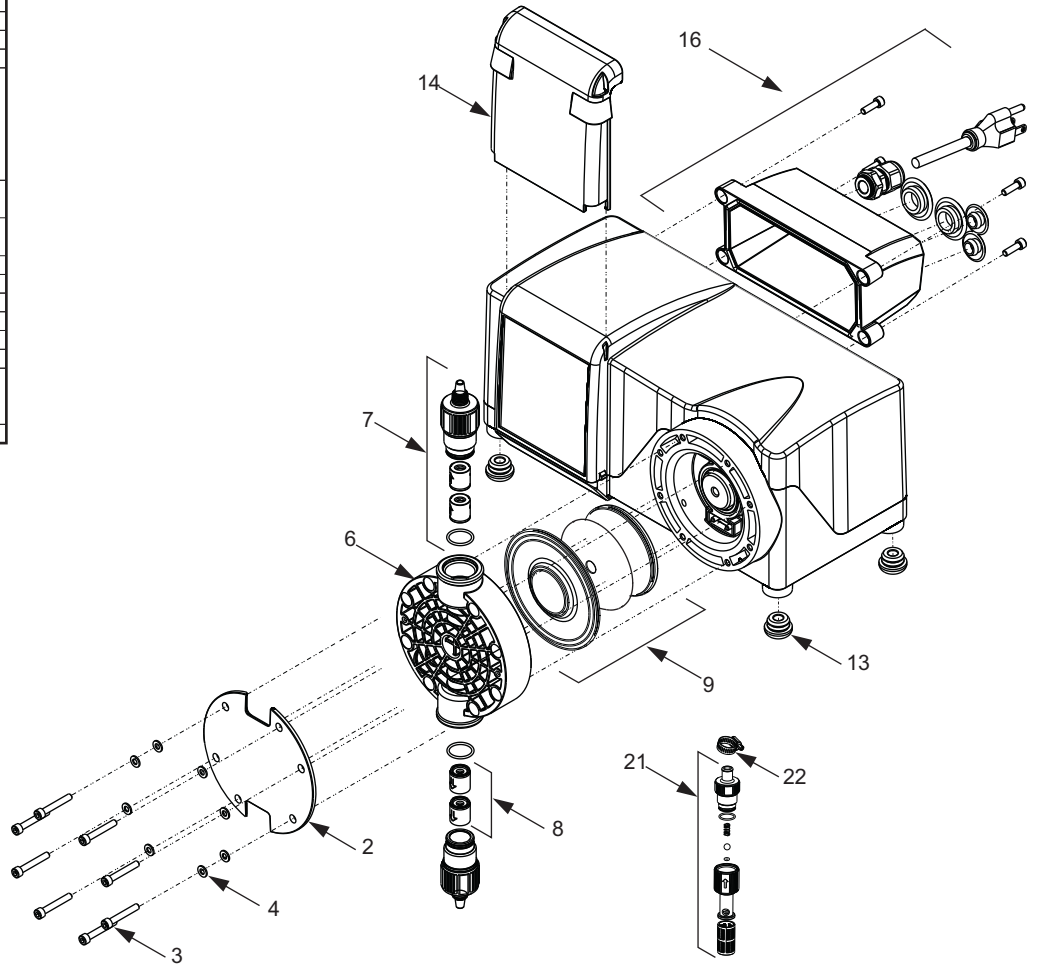

### 16.0 DFD (Diaphragm Failure Detection)

Chem-Pro® is equipped with a Diaphragm Failure Detection System which is designed to stop pump and provide an output alarm in event diaphragm should rupture and chemical enters pump head. Pump will detect a chemical with a conductivity reading greater than 500 microsiemens. Chemicals with a conductivity of less than 500 microsiemens will not be detected.

This system is capable of detecting presence of a large number of chemicals including Sodium Hypochlorite (Chlorine), Hydrochloric (muriatic) Acid, Sodium Hydroxide, and many others. System will not be triggered by water (rain, condensation, etc.) or lubricants.

If system has detected chemical, pump diaphragm must be replaced and pump head must be thoroughly cleaned. Failure to clean pump head will void warranty.

If DFD alarm occurs, pump will stop, close an alarm output, and screen will flash DFD with an alarm icon.

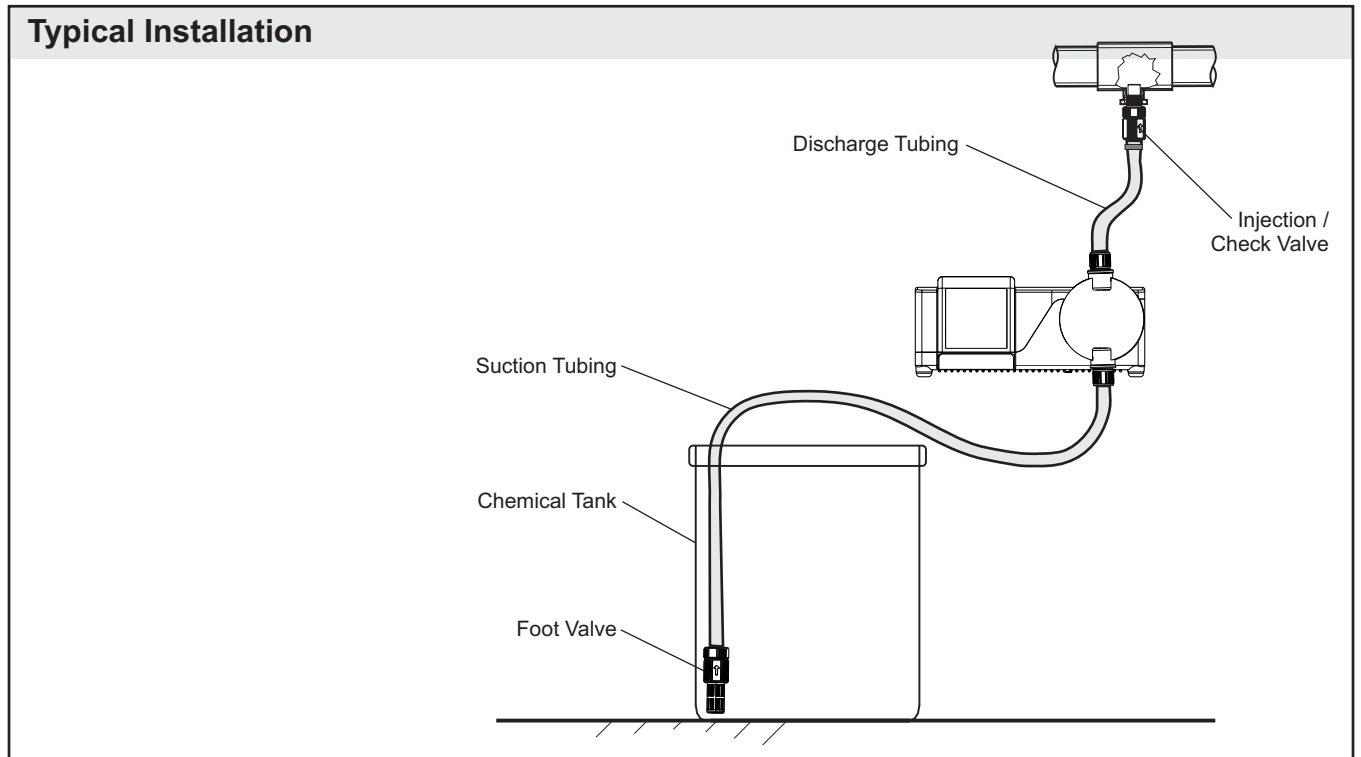
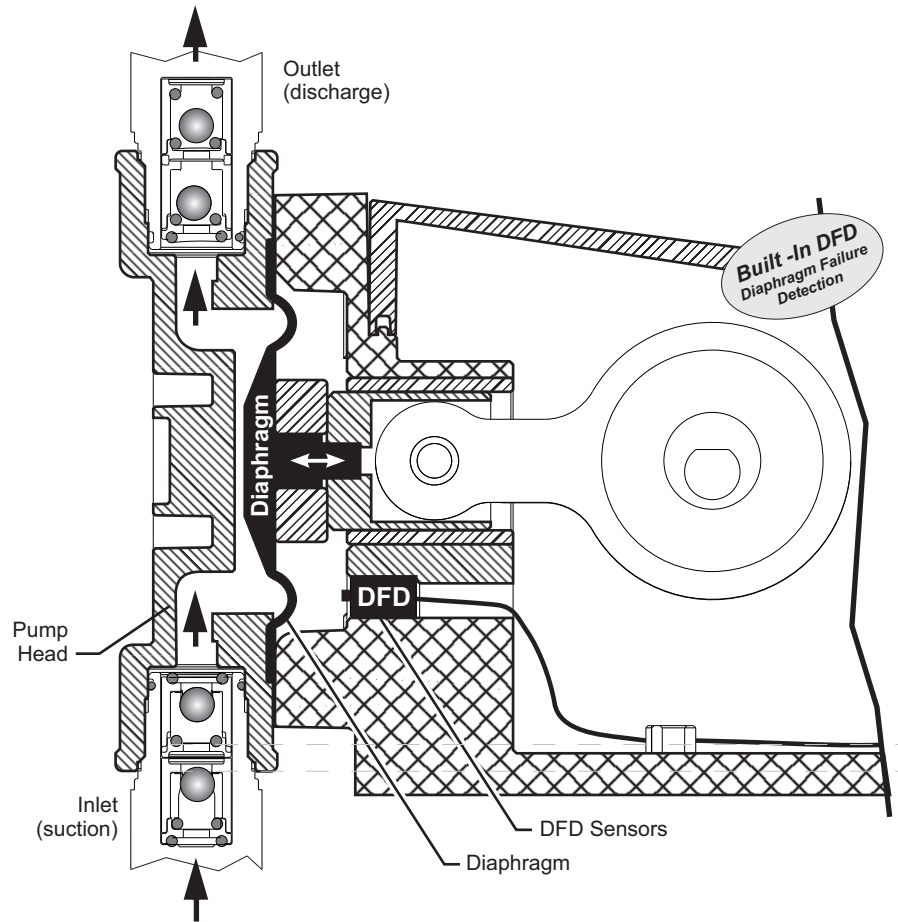

17.0 Output Versus Pressure

17.1 MC-2 Output V. Pressure

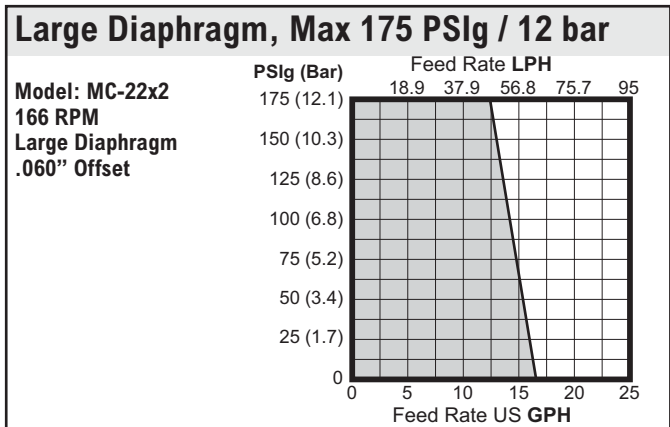
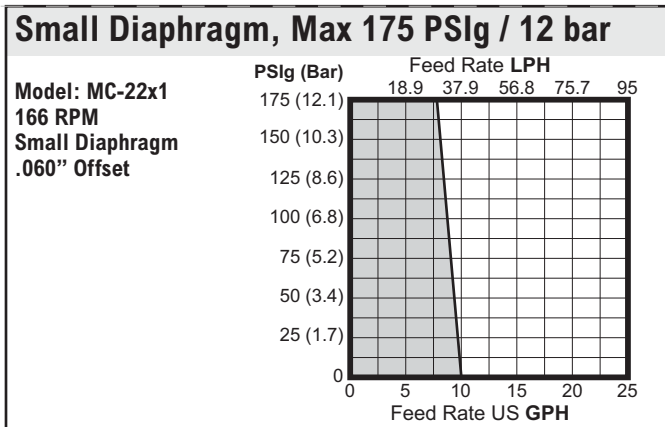
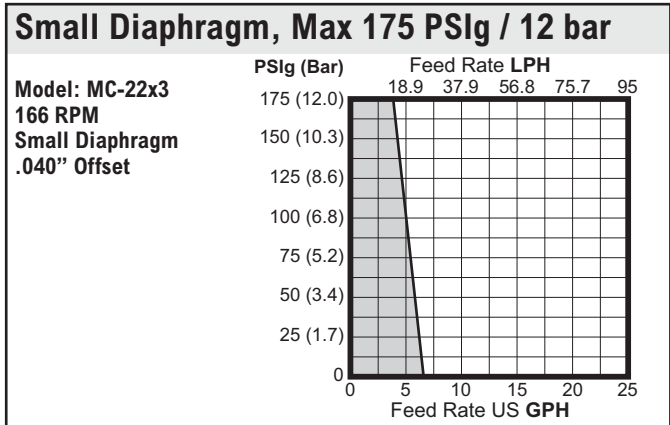
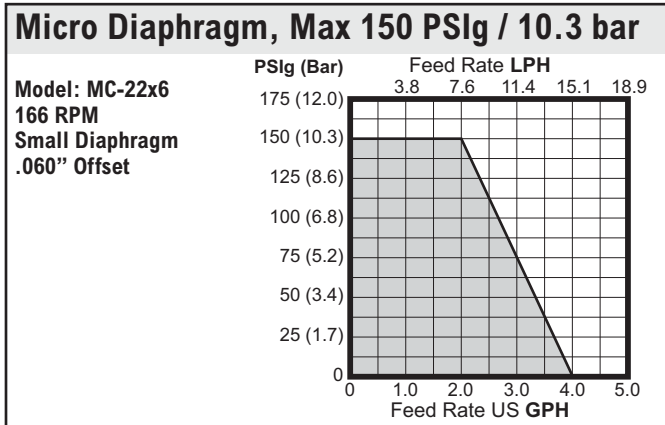
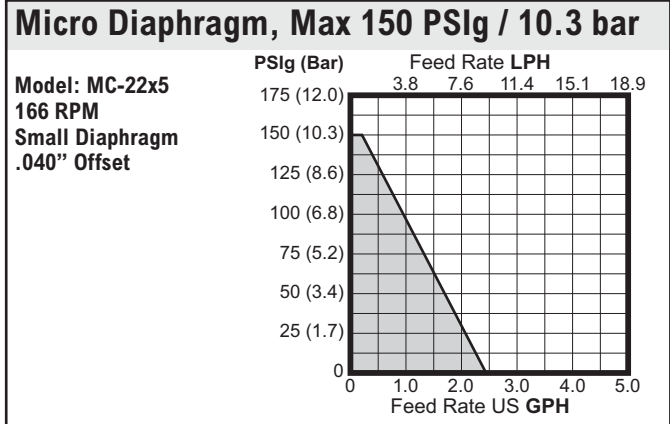

17.2 MC-3 Output V. Pressure

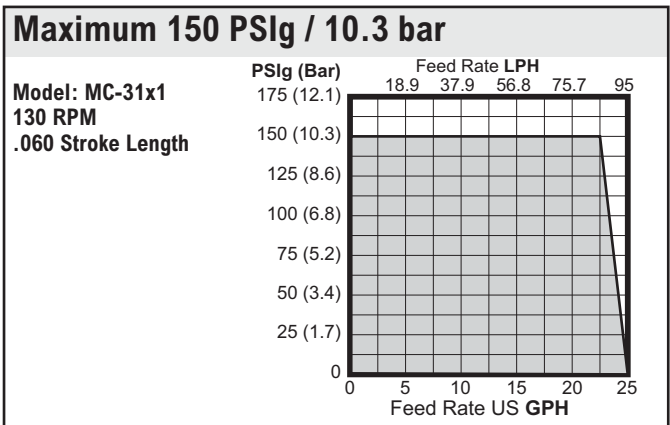
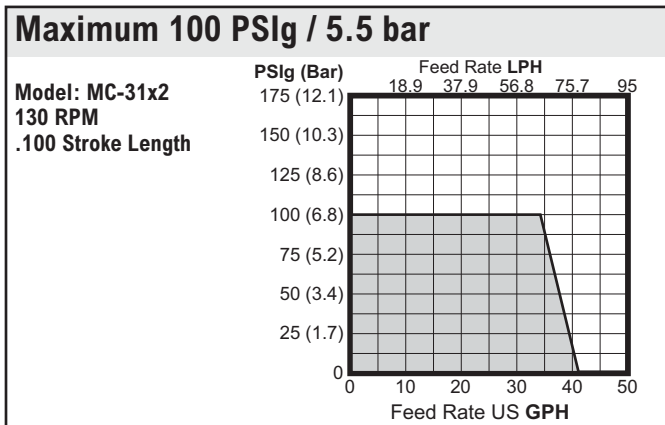

### LIMITED WARRANTY

Your new Chem-Pro pump is a quality product and is warranted for 36 months from date of purchase (proof of purchase is required). The pump will be repaired or replaced at our discretion.

### WHAT IS NOT COVERED

- **Pump diaphragm and rubber components – They are perishable and require periodic replacement.**
- **Pump removal, or re-installation, and any related labor charge.**
- **Freight to the factory, or ProSeries service center.**
- **Pumps that have been tampered with, or in pieces.**
- **Damage to the pump that results from misuse, carelessness such as chemical spills on the enclosure, abuse, lack of maintenance, or alteration which is out of our control.**
- **Pumps damaged by faulty wiring, power surges or acts of nature.**

Blue-White Industries does not assume responsibility for any loss, damage, or expense directly or indirectly related to or arising out of the use of its products. Failure must have occurred due to defect in material or workmanship and not as a result of operation of the product other than in normal operation as defined in the pump manual.

Warranty status is determined by the pump's serial label and the sales invoice or receipt. The serial label must be on the pump and legible. The warranty status of the pump will be verified by Blue-White Industries or a factory authorized service center.

### OTHER IMPORTANT WARRANTY INFORMATION

Please be advised; injection and metering devices are not intended as a means of treating water to render it suitable for human consumption. When used as hypochlorinators, they are meant to destroy bacteria and algae contamination, before its removal by filtration. Acid and soda injectors are used for PH control (balance). Blue-White Industries injectors are factory tested with water only for pressure and performance. Installers and operators of these devices must be well informed and aware of the precautions to be taken when injecting various chemicals -especially those considered hazardous or dangerous, eye protection must be worn when working around this product or any other metering type of pump.

Should it become necessary to return the pump for repair or service, you must attach information regarding the chemical used as some residue may be present within the unit which could be a hazard to service personnel.

Blue-White Industries will not be liable for any damage that may result by the use of chemicals with their injectors and its components. Thank you.

### PROCEDURE FOR IN WARRANTY REPAIR

Contact the factory to obtain a RMA (Return Material Authorization) number. Carefully pack the pump to be repaired. It is recommended to include foot strainer and injection/check valve fitting since these devices may be clogged and part of the problem. Please enclose a brief description of the problem as well as the original invoice or sales receipt, or copy showing the date of purchase. Prepay all shipping costs. COD shipments will not be accepted. Warranty service must be performed by the factory or an authorized ProSeries service center. Damage caused by improper packaging is the responsibility of the sender. When In-Warranty repair or replacement is completed, the factory pays for return shipping to the dealer or customer.



Users of electrical and electronic equipment (EEE) with the WEEE marking per Annex IV of the WEEE Directive must not dispose of end of life EEE as unsorted municipal waste, but use the collection framework available to them for the return, recycle, recovery of WEEE and minimize any potential effects of EEE on the environment and human health due to the presence of hazardous substances. The WEEE marking applies only to countries within the European Union (EU) and Norway. Appliances are labeled in accordance with European Directive 2002/96/EC. Contact your local waste recovery agency for a *Designated Collection Facility* in your area.

**ProSeries<sup>®</sup>**  
by Blue-White Ind.

5300 Business Drive, Huntington Beach, CA 92649 USA

Phone: 714-893-8529 FAX: 714-894-9492

E mail: sales@blue-white.com or techsupport@blue-white.com URL: www.ProSeries-M.com