

SUBMITTAL INFORMATION

Monitor Cover - (No. MC-xx-T style)

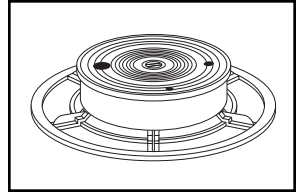

MONITOR COVER WITH LOCKING ELECTRONIC METER READING LID

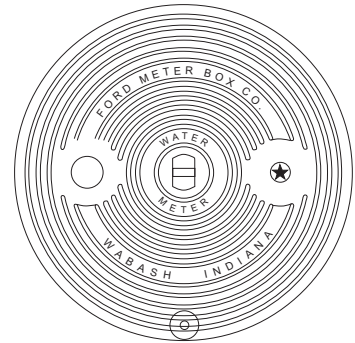
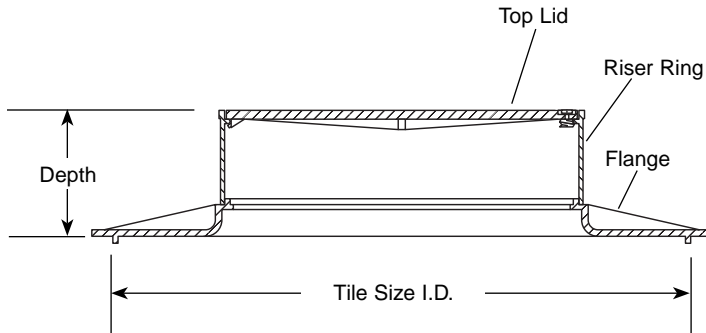

Lid Size*	Cover Depth	Tile Size I.D.	Approx. Wt. Lbs.	Part Number	✓ Submitted Items
20"	7-1/2"	24"	103.0	MC-24-T	
20"	7-1/2"	30"	131.0	MC-30-T	
20"	8"	36"	185.0	MC-36-T	
20"	7-1/2"	24"	127.0	MC-24H-T	
20"	7-1/2"	30"	155.0	MC-30H-T	
20"	8"	36"	209.0	MC-36H-T	
20"	7-1/2"	24"	136.0	MC-24HH-T	
20"	7-1/2"	30"	164.0	MC-30HH-T	
20"	8"	36"	218.0	MC-36HH-T	

*Lid size indicates approximate pit access opening; actual lid diameter is approximately 1" larger.

FEATURES

- Manufactured of cast iron per ASTM A48-92 Class 25
- Hat-shape design to minimize surface exposure and provide additional ground insulation.
- Inset lid design rests flush with the top of the Riser Ring.
- Standard pentagon bolt furnished with locking lids.
Larger size is available. Add "-LB" to catalog number. For non-locking lid, add "-LL".
- Lid has 2" precast hole for electronic meter reading modules.
Add to catalog number: "-TT" for two E-Read holes.

The Ford Meter Box Company considers the information in this submittal form to be correct at the time of publication. Item and option availability, including specifications, are subject to change without notice. Please verify that your product information is current.



The Ford Meter Box Company, Inc.

P.O. Box 443, Wabash, Indiana U.S.A. 46992-0443
 Phone: 260-563-3171 / Fax: 800-826-3487
 Overseas Fax: 260-563-0167
<http://www.fordmeterbox.com>

05/03/06



36 Hudson Rd
 Sudbury MA 01776



800-225-4616
www.tisales.com