

Critical Communication and Easy Migration

Neptune® R900® System: LoRaWAN® Endpoints



Neptune's R900® System endpoints greatly improve access to meter readings while delivering accurate, detailed, and timely consumption information to proactively identify and resolve high bill complaints, reduce delinquent payments, and eliminate write-offs to maximize revenue. The user-friendly, intuitive endpoint design simplifies the installation process and increases operational efficiency.

Neptune® LoRaWAN® wall and pit endpoints provide continuous transmission of meter data and the flexibility of mobile or fixed network reading methods. The built-in LoRaWAN technology improves range, supports time synchronization for top-of-the-hour readings, and provides robust, end-to-end security. Migrate easily to AMI when you're ready without separate reading systems, site visits, or endpoint reconfiguration. When combined with Network-as-a-Service (NaaS), alleviate the operational burden of network maintenance while ensuring service area coverage.

- Improve meter reading efficiency with robust walk-by, mobile, and long-range fixed network connectivity
- Build on to existing technology investments with forward and backward compatible endpoints
- Improve quality of service and billing accuracy with detailed top-of-the-hour consumption data
- Fast installation and no programming required
- Works seamlessly with existing assets and future enhancements
- Pinpoint trouble areas quickly with flags that identify leaks, reverse flow, and tampering
- Peace of mind with access to 96 days of stored history and end-to-end data security



NEPTUNE
TECHNOLOGY GROUP

#winyourday

Technical Specifications

Electrical Specifications

- Endpoint power: Lithium battery with capacitor

Transmitter Specifications

- Two-way endpoint
- Transmit options (interleaved mobile and fixed network messages):
 - R900 mobile message
 - R900 fixed network message
 - LoRaWAN® fixed network message
- FCC verification: Part 15.247
 - Transmitter channels: 50 (R900 mobile and fixed network messages) and 64 (LoRaWAN fixed network message); frequency-hopping, spread-spectrum
 - Frequency range: 902 to 928 MHz
- Encoder register reading interval:
 - Every 15 minutes
- Data logging interval:
 - 96 days of hourly data

Environmental Conditions

- Operating temperature:
-22°F to +149°F (-30°C to +65°C)
- Storage temperature:
-40°F to +158°F (-40°C to +70°C)
- Operating humidity:
100% condensing

Antennas

- Wall endpoint: standard internal antenna
- Pit endpoint: standard through-the-lid antenna
 - 18" Coax
 - 6' Coax
 - 20' Coax

Encoded Register Compatibility

- Neptune ARB® V, ProRead™, ProCoder™, and E-CODER®
- Sensus ECR II, ICE, iPerl, Electronic Register and OMNI
- Hersey/Mueller Translator
- Badger ADE and HR E|LCD
- Elster/AMCO InVision (Sensus protocol version)

Options

System Compatibility

- Handhelds with R900® belt clip transceiver - mobile RF
- R900 mobile data collector - mobile RF
- R900 gateways - fixed network RF
- LoRaWAN gateway and NaaS

Dimensions

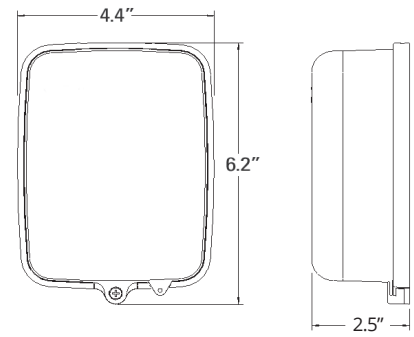

LoRaWAN® Wall Endpoint

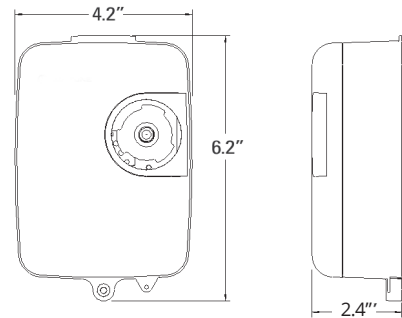

LoRaWAN® Pit Endpoint

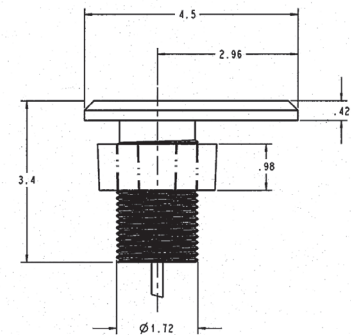

LoRaWAN® Pit Antenna



36 Hudson Rd
Sudbury, MA 01776

800.225.4616
www.tisales.com



Metering Systems Support
978.261.7683