

SUBMITTAL INFORMATION

Restrained Coupling for PVC Pipe - (RCPP-xx-I style)

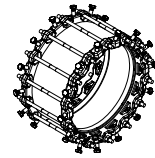

14" - 36" RESTRAINED COUPLING FOR AWWA C900, C909 OR HDPE PIPE

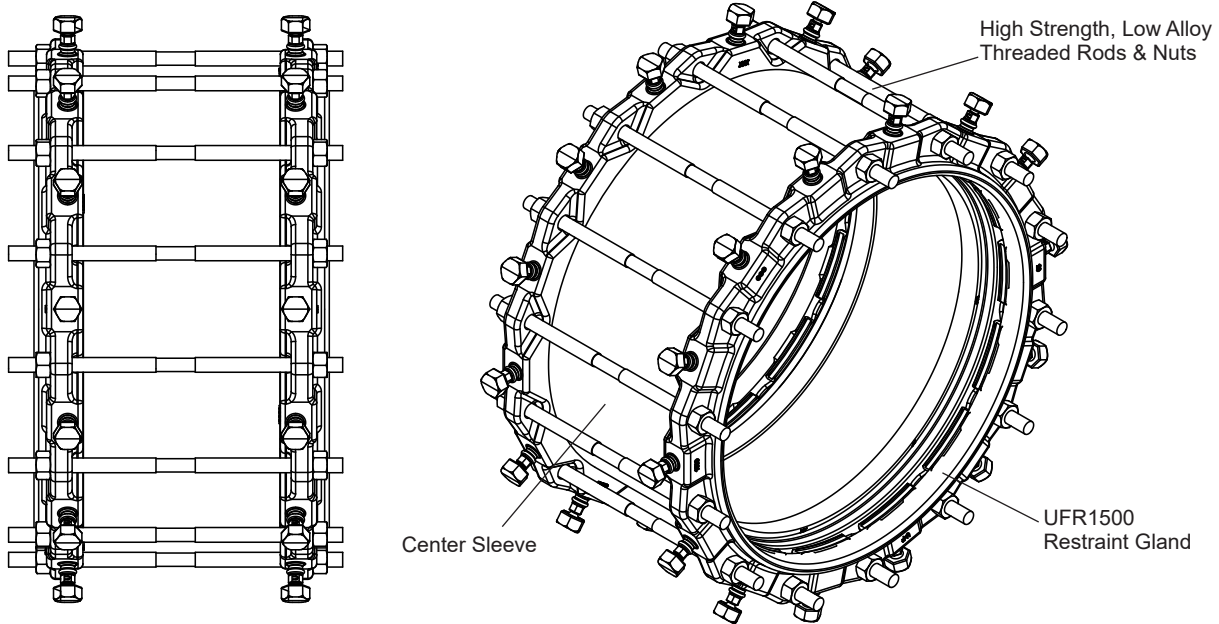

NOMINAL PIPE SIZE	PIPE O.D. RANGE (INCHES)	SLEEVE LENGTH	DEGREES DEFLECTION	No. OF RODS	SIZE OF RODS	APPROX. Wt. LBS	PART NUMBER	✓ SUBMITTED ITEM(S)
14"	15.30	10"	3°	10	3/4" x 17"	185	RCPP-14-I	
16"	17.40	10"	3°	12	3/4" x 17"	230	RCPP-16-I	
18"	19.50	10"	3°	12	3/4" x 17"	270	RCPP-18-I	
20"	21.60	10"	3°	14	3/4" x 17"	310	RCPP-20-I	
24"	25.80	10"	3°	16	3/4" x 17"	400	RCPP-24-I	
30"	32.00	10"	1°	20	1" x 20"	520	RCPP-30-I	
36"	38.30	10"	1°	24	1" x 20"	640	RCPP-36-I	

FEATURES

- Center Sleeve - Carbon steel per ASTM A36, black enamel shop coat
- Restraint Gland Ends - Ductile iron per ASTM A536, e-coat epoxy with red top coat
- Double End Rod & Nuts - High strength, low alloy steel per ASTM A242 and AWWA C111
- Gaskets - SBR rubber per ASTM D2000
- Rated to the pressure rating of the pipe on which is it installed with a 2:1 safety factor
- Fabricated sleeve and imported ductile iron restraint castings
- May be used on ductile sized HDPE with an approved insert
- Complies with AWWA C219

The Ford Meter Box Company considers the information in this submittal form to be correct at the time of publication. Item and option availability, including specifications, are subject to change without notice. Please verify that your product information is current. Our standard warranty applies.



The Ford Meter Box Company, Inc.
 P.O. Box 443, Wabash, Indiana U.S.A. 46992-0443
 Phone: 260-563-3171 / Fax: 800-826-3487
 Overseas Fax: 260-563-0167
 www.fordmeterbox.com

10/12/21

Submitted By:



36 Hudson Rd
 Sudbury MA 01776



800-225-4616
 www.tisales.com