

AVK CHECK VALVES

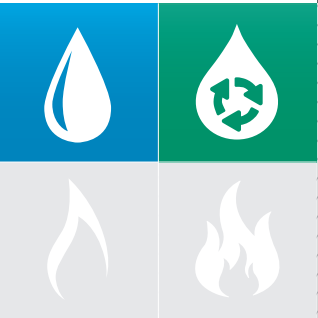
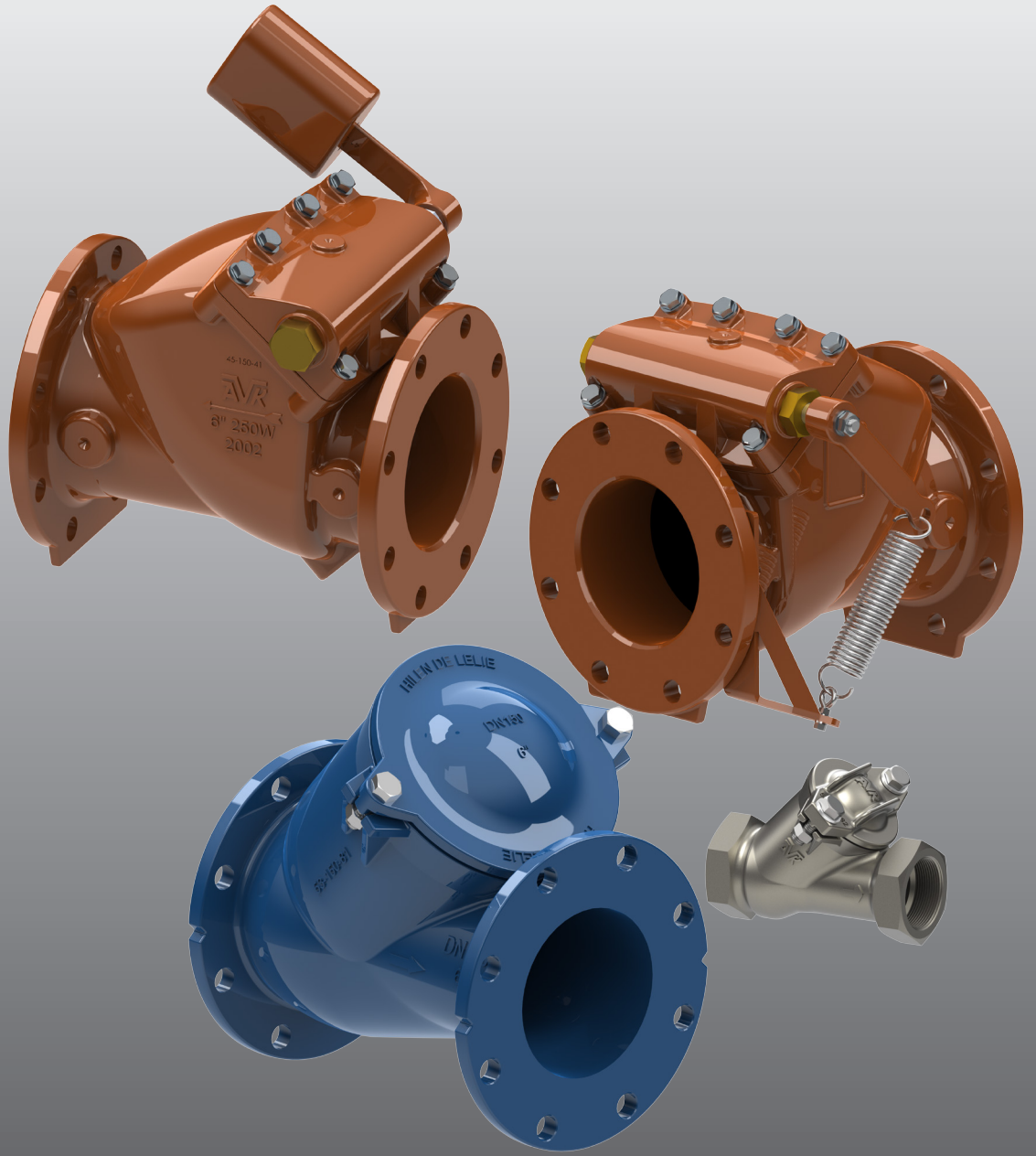

EXPECT
SUPERIOR
DESIGN

Expect... **AVR**

AVK SWING CHECK VALVES

AVK offers a wide range of swing check valves featuring a clear waterway and low head loss, resulting in maximum utilization of pump capacity. The check valves can be installed in both horizontal and vertical positions and are easy to maintain. Different options are available for prevention of water hammer.

EASE OF MAINTENANCE

- The AVK Series 41 is designed to be the easiest to maintain check valve on the market. Simply remove the bonnets bolts – bonnet, hinge, and disc can be removed as one unit, leaving the valve body inline. The valve can then be easily cleaned and any repairs can be made without having to reach into the valve. A new head assembly can be installed immediately to reduce downtime.



CLEAR WATERWAY DESIGN

- For improved flow characteristics and lower head loss, the AVK swing check valve is a clear waterway design. There are no obstructions in the flow path for a 100% clear waterway

EXPECT FUNCTIONALITY

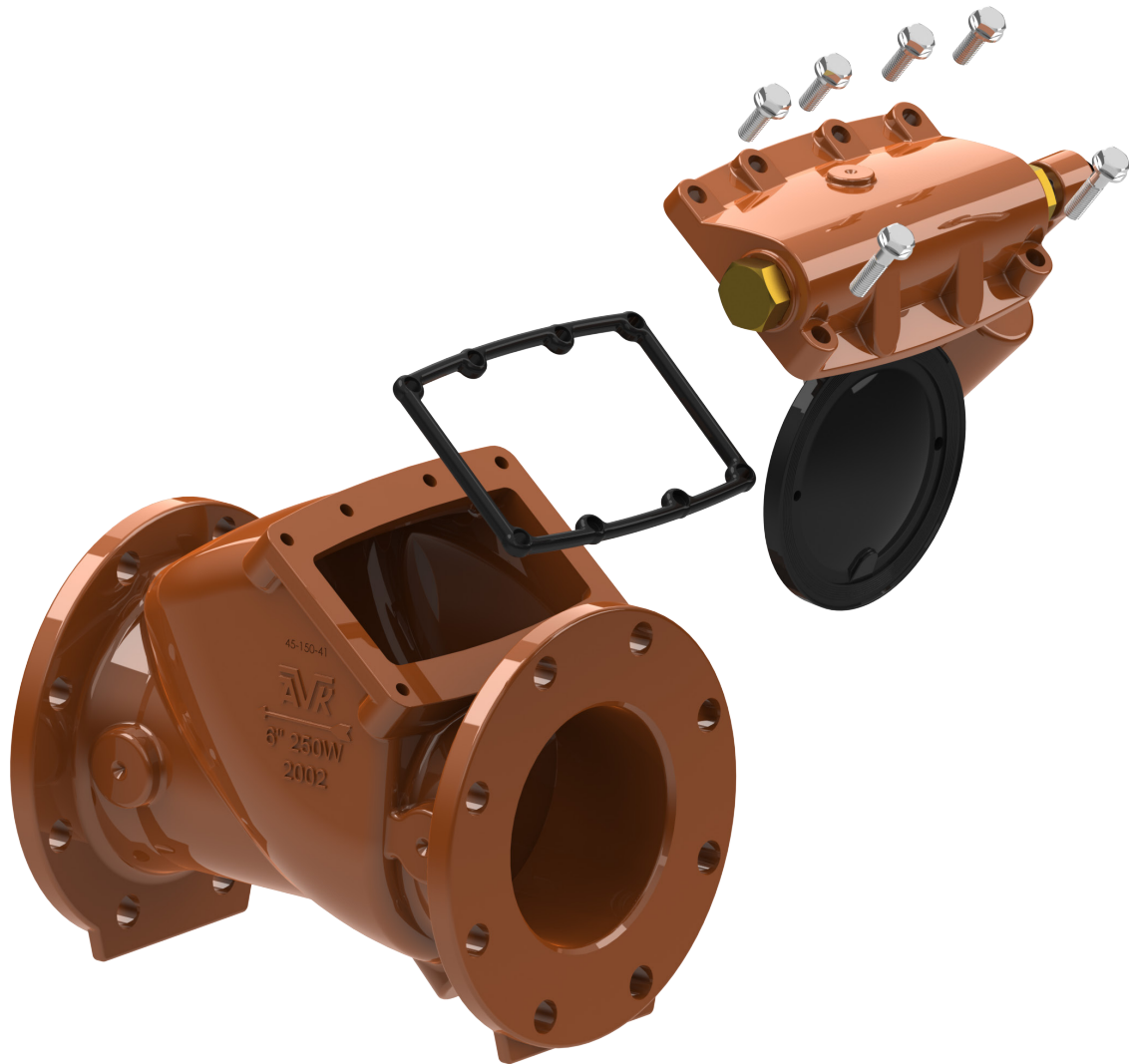

SWING CHECK VALVE FEATURES

- Meets or exceeds AWWA C508
- Available in 3" through 12"
- All internal exposed metal is stainless steel or fusion bonded epoxy coated
- Lightweight disc reduces inertia and assists in closing
- Reduced opening angle for faster closure
- Tested to 1,000,000 cycles; rated to 250 psi
- Easily maintained, with no need to remove valve from the line
- Steel disc is encapsulated in EPDM rubber
- Hinge, bonnet and disc are one easily removable assembly
- Interior and exterior, fusion bonded, epoxy coating meets or exceeds the requirements of AWWA C550
- Hinge shaft is sealed with o-rings for long-life and easy replacement
- Stainless steel bonnet bolts are sealed by bonnet gasket

EXPECT SERVICEABILITY

OPTIONS

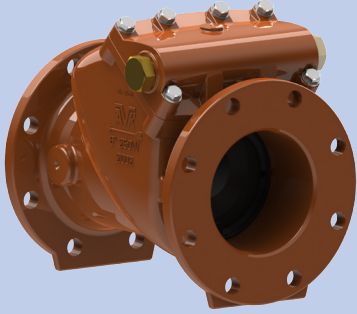

STANDARD CHECK VALVE

- Standard swing check valve is provided without lever and weight or springs

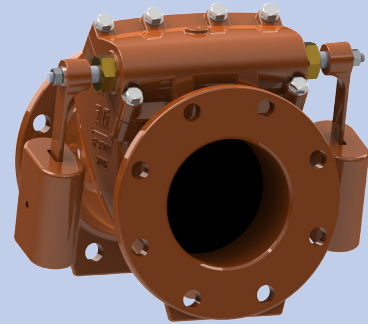

DUAL LEVER AND WEIGHT

- Additional option for accelerated closure

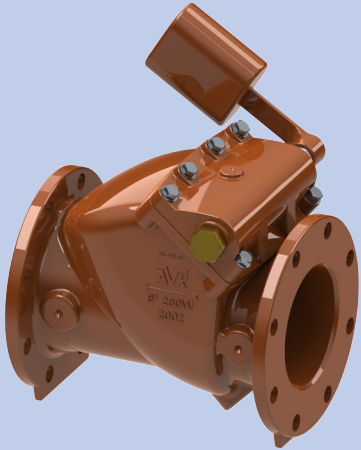

LEVER AND WEIGHT

- A lever and weight may be mounted on either the left-hand or right-hand side. Right-hand mounting is standard.

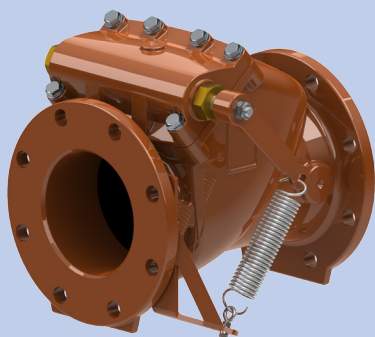

LEVER AND SPRING

- A lever and spring can be also provided to assist with quicker closure

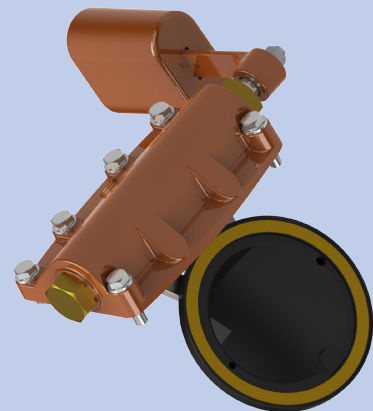

BRONZE SEATED DISC

- Bronze seated valves also available

AVK BALL CHECK VALVES

AVK ball check valves feature a clear waterway and low head loss to maximize efficient utilization of pump capacity. Random seating of the ball, on closing, ensures long life. Check valves can be installed in both horizontal and vertical positions and are easy to maintain. Sinking and floating balls are available for different installation configurations.

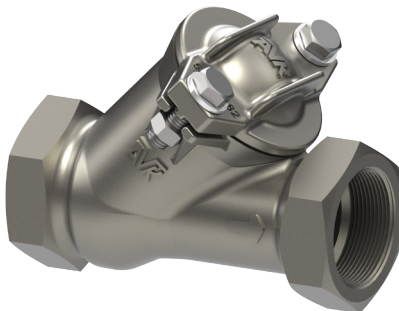
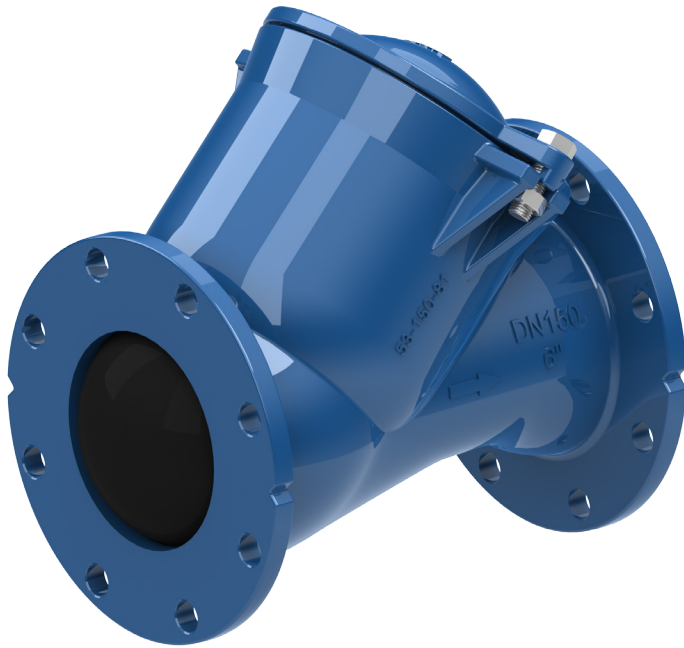

BALL CHECK VALVE FEATURES

- Flange to flange dimensions are to ANSI/ASME B16.10
- Flanged sizes available in 2" through 24", ductile iron
- Ductile iron and stainless steel NPT available in 1½" and 2" sizes
- Pressure rated to 150 psi
- 100% testing – All valves tested to 150 psi leak test/225 psi hydrostatic shell test
- Simple bolt-on cover for easy inspection and maintenance
- Can be mounted vertically or horizontally
- Vertical installations can have downward flow when floating ball is used
- Nitrile (NBR) and Polyurethane (PUR) balls available

American AVK Company Locations

American AVK Company

2155 Meridian Blvd.
Minden, NV
89423
USA

Tel.: 775-552-1400
Fax.: 775-552-1031
www.americanavk.com

GenCV_TFB/03-20-2014
Copyright©AVK Group A/S 2014

Ti SALES

36 Hudson Rd
Sudbury MA 01776



800-225-4616
www.tisales.com

Expect... **AVR**