

AMERICAN AVK SWING CHECK VALVE, 250 PSI
Tested to AWWA C508 - Resilient Seated with Lever & Weight
Flanged Ends Drilled to ANSI B16.1 Class 125 - Valve Sizes 3" - 12"

41/42-43X
RSLT/LW

Use:

For potable water and sewage to maximum 160°F.

Tests:

Hydraulic test to AWWA C508:

Shell Test: 500 PSI

Seat Test: 250 PSI

Optional Extras:

Available with Lever right-hand or left-hand mounted.

Dual Lever&Weight

Tapping boss, tapped and plugged.

Priming Device (3-inch through 8-inch)

Standard Materials:

Body, Bonnet, Weight, Lever Hinge (10"-12") Ductile iron, ASTM A536

Coating Electrostatically applied fusion-bonded epoxy. Meets or exceeds AWWA C550

O-Rings, Bonnet Gasket NBR

Shaft, (Hinge, 3"- 8") Bonnet Bolts, Washers, Keys Stainless steel

Bushings Bronze

Resilient Seated Disc EPDM rubber with a carbon steel core

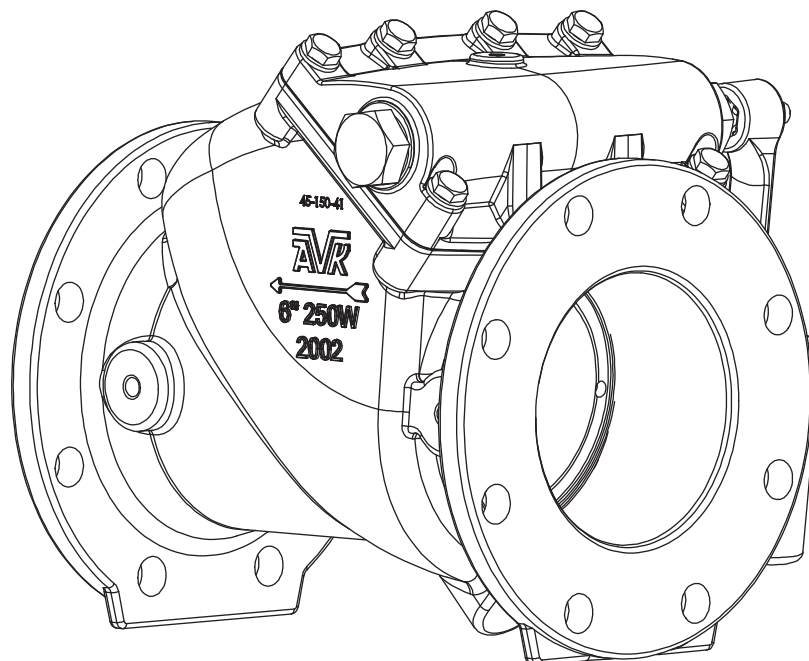

C508 clear waterway design. Laylength to ANSI B16.10



AMERICAN AVK SWING CHECK VALVE, 250 PSI
Tested to AWWA C508 - Resilient Seated with Lever & Weight
Flanged Ends Drilled to ANSI B16.1 Class 125 - Valve Sizes 3" - 12"

41/42-43X
RSLT/LW

Components

400. Body	406. Bonnet Bolt	412. Bonnet Gasket	418. Inner Bushing O-ring	423. Disc Lock Washer**
401. Disc Nut	407. Bonnet	413. Disc	419. Weight	429. Bonnet O-ring*
402. Disc Washer	408. Shaft	414. Shaft Nut	420. Set Screw	430. Hinge Connector*
403. Disc Bushing	409. Key	415. Shaft Washer	421. Outer Bushing O-ring	431. Retaining Washers*
404. Hinge	410. Lock Washer	416. Lever	422. Closed Bushing	432. Shaft Spacers*
405. Bonnet Washer	411. Hinge Bolt	417. Open Bushing		

* 10" and 12" Valves (not shown)

** As of March 1st, 2008 on 3" through 8" valves, the Disc Lock Washer (423), and Disc Nut (401), are replaced by a new self locking Disc Nut (401).

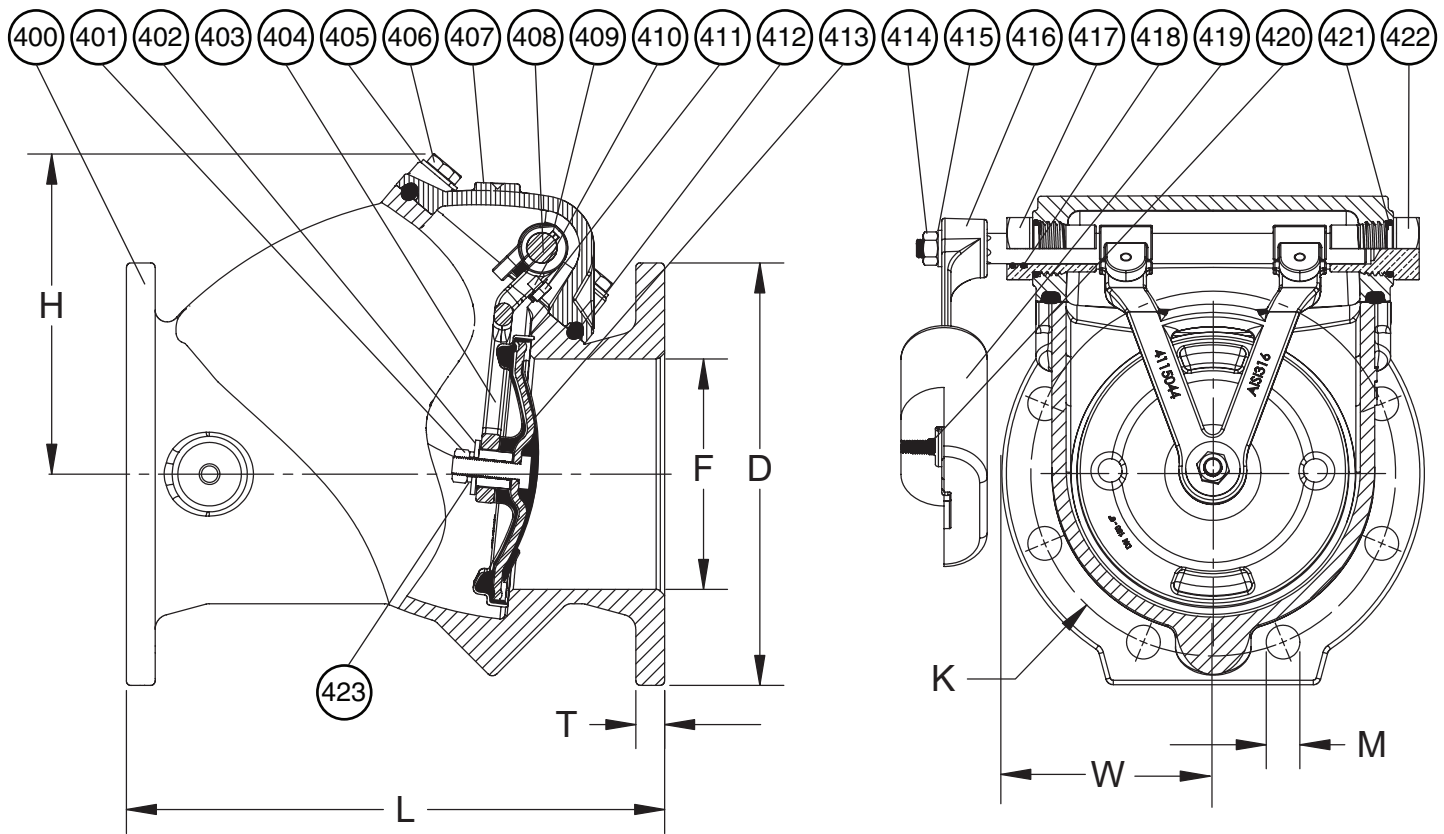

Ref No.	Size	D	F	H	K	L	M	T	W	Flange Holes	Weight (lbs.)
41-080-42-43X	3"	7.50"	3.00"	5.50"	6.00"	9.50"	0.75"	0.75"	3.76"	4	35
41-100-42-43X	4"	9.00"	4.00"	6.00"	7.50"	11.50"	0.75"	0.75"	4.50"	8	51
41-150-42-43X	6"	11.00"	6.00"	7.75"	9.50"	14.00"	0.88"	0.75"	5.50"	8	86
41-200-42-43X	8"	13.50"	8.00"	9.00"	11.75"	19.50"	0.88"	0.80"	6.75"	8	165
41-250-42-43X	10"	16.00"	10.00"	13.50"	14.25"	24.50"	1.00"	1.20"	8.01"	12	450
41-300-42-43X	12"	19.00"	12.00"	15.37"	17.00"	27.50"	1.00"	1.26"	9.50"	12	590

42 = Lever & Weight Right Side

43 = Lever & Weight Left Side



36 Hudson Rd
 Sudbury MA 01776



800-225-4616
 www.tisales.com

DS S41/4243X RSLT LW
 Subject to change without notice. (rev. 01/13)