

AMERICAN AVK RESILIENT SEATED DUCTILE IRON GATE VALVE
250 PSI, Tested to AWWA C509 / C515 (NRS)
Mechanical Joint Ends - Valve Sizes 4" - 16"

45/0X
MJxMJ

Use:

For water and neutral liquids to maximum 160°F.

Tests:

Hydraulic test to AWWA C509:

Shell Test: 500 PSI

Seat Test: 250 PSI

Operating Torque Test

Optional Materials:

Stem	Option a): For UL, FM, ULC Low zinc bronze ASTM B763
Anti Friction Washers	Polyamide
Bonnet Bolts	Option a): For UL, FM, ULC ASTM A164 zinc coated steel sealed with hot melt Option b): Stainless Steel - 316 sealed with hot melt
Gland Bolts	Option a): For UL, FM, ULC ASTM A164 zinc coated steel Hexagon bolt Option b): Stainless Steel - 316 Hexagon bolt

Standard Materials:

Body, Bonnet, Gland Flange, Wrench Nut	Ductile iron ASTM A536 (Wrench Nut-painted black for open left, red for open right)
Coating	Electrostatically applied fusion- bonded epoxy-resin Meets or exceeds AWWA C550
Stem	Standard: Stainless steel ASTM A582
Wedge	Ductile iron ASTM A536 encapsulated with EPDM-rubber compound
Wedge Nut, Thrust Collar Bonnet Bolts	Bronze Stainless Steel - 304 sealed with hot melt
Gland Bolts	Stainless Steel - 304 Hexagon bolt
Bonnet Gasket, Wiper Ring, O-Ring Stem Seals, O-Ring Gland Seal	ASTM D2000 Buna "N" nitrile rubber

Approvals:



*UL/ULC Listed, 4" -12"

*FM Approved, 4"-12"

NSF-61 (audited by UL), 4"- 16"

* Approved at 250 PSI working pressure

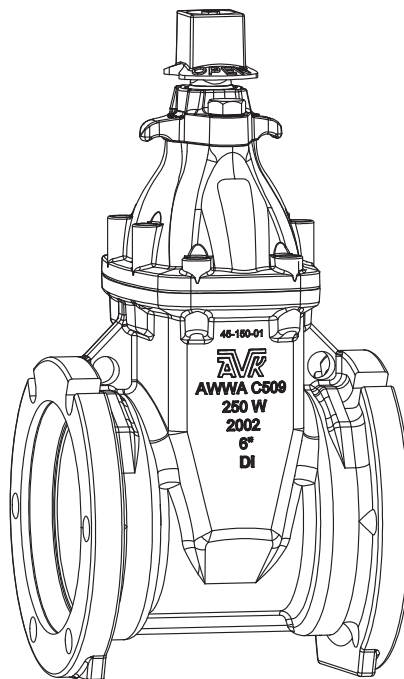

American AVK Company
an ISO 9001-2000 registered company

DS S450X MJMJ
Subject to change without notice. (rev. 03/08)

AMERICAN AVK RESILIENT SEATED DUCTILE IRON GATE VALVE
250 PSI, Tested to AWWA C509 / C515 (NRS)
Mechanical Joint End - Valve Sizes 4" - 16"

45/0X
MJxMJ

Component List:

- | | | |
|--------------------|------------------------------|-----------------------------|
| 217. Bonnet | 227. Gland Flange Bolt | 232. Lower Stem Seal O-Ring |
| 218. Bonnet Gasket | 228. Gland Flange | 233. NRS Stem |
| 219. Body | 229. Gland O-Ring | 234. Thrust Collar |
| 225. Wrench Nut | 230. Upper Stem Seal O-Rings | 237. Wedge |
| 226. Wiper Ring | 231. Stem Seal Bushing | |

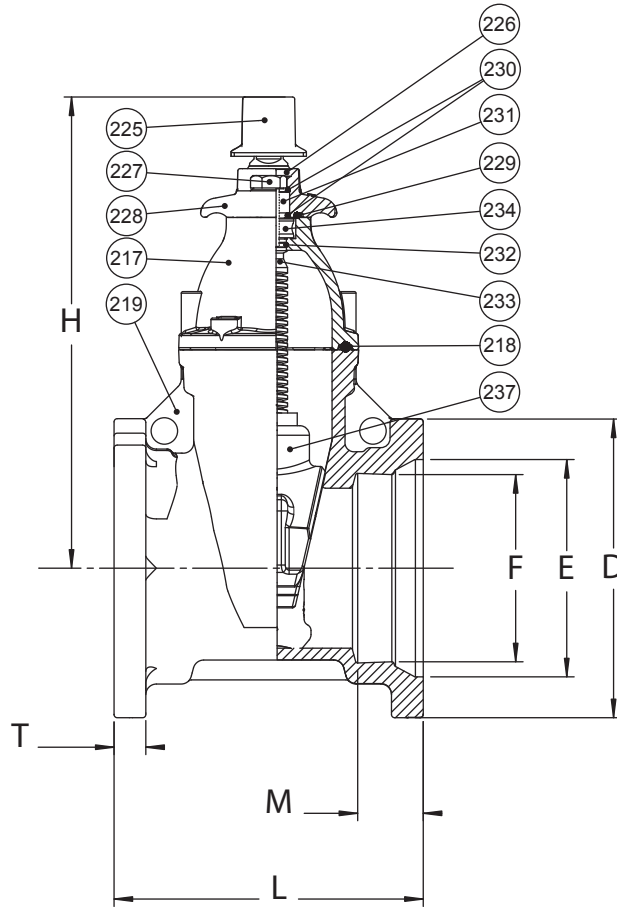

Ref No.	Size	D	E	F	H	L	M	T	Turns to Open	Weight (lbs.)
45-100-0X	4"	9.12"	6.00"	4.90"	13.50"	10.00"	2.50"	1.00"	14	62
45-150-0X	6"	11.12"	8.12"	7.00"	17.50"	11.50"	2.50"	1.18"	21	103
45-200-0X	8"	13.37"	10.27"	9.15"	21.50"	11.50"	2.50"	1.24"	26	155
45-250-0X	10"	15.69"	12.34"	11.20"	24.75"	13.00"	2.50"	1.14"	32	240
45-300-0X	12"	17.88"	14.44"	13.30"	27.63"	14.00"	2.50"	1.22"	38	337
45-350-0X	14"	20.31"	16.61"	15.50"	35.75"	17.95"	3.50"	1.32"	51	794
45-400-0X	16"	22.56"	18.64"	16.12"	34.75"	18.00"	3.50"	1.34"	51	800



36 Hudson Rd
 Sudbury MA 01776



800-225-4616
 www.tisales.com