

**AMERICAN AVK RESILIENT SEATED DUCTILE IRON GATE VALVE**  
**250 PSI, Tested to AWWA C509 (OS&Y)**  
**ANSI B16.1 Class 125 Flanged x Flanged Ends - Valve Sizes 2 1/2" - 12"**

**45/45X**  
**FLxFL**

**Use:**

For water and neutral liquids to maximum 160°F.

**Tests:**

Hydraulic test to AWWA C509:

Shell Test: 500 PSI

Seat Test: 250 PSI

Operating Torque Test

**Optional Materials:**

Bonnet Bolts, Stud Bolts	Stainless Steel,
Washers, Nuts	Grade 304

**Standard Materials:**

Body, Bonnet, Yoke, Gland Follower	Ductile iron ASTM A536
Handwheel	Cast iron ASTM A126 class B
Coating	Electrostatically applied fusion-bonded epoxy-resin Meets or exceeds AWWA C550
Stem, Anti-Friction Washer, Wedge Nut 2-piece Stem Nut	Bronze
Wedge	Ductile iron ASTM A536 encapsulated with EPDM - rubber compound.
Bonnet Bolts	4"-8": ASTM A 164 Zinc Plated Steel 10"-12": Grade 8 Steel
Stud Bolts, Washers, Nuts	Zinc Plated Steel
Bonnet Gasket, O-rings	NBR
Gland, Gland Bushing	Akulon

**Approvals:**



\*UL/ULC Listed,

\*FM Approved

\* Approved at 250 PSI working pressure

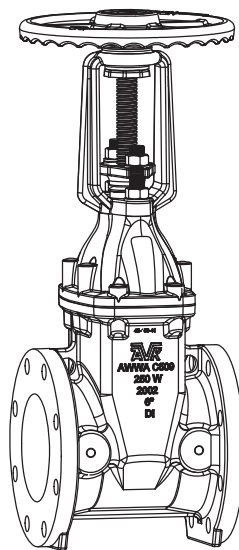

**AMERICAN AVK RESILIENT SEATED DUCTILE IRON GATE VALVE**  
**250 PSI, Tested to AWWA C509 (OS&Y)**  
**ANSI B16.1 Class 125 Flanged x Flanged Ends - Valve Sizes 2 1/2" - 12"**

**45/45X**  
**FLxFL**

**Component List:**

- |                                 |                           |                               |
|---------------------------------|---------------------------|-------------------------------|
| 201. Upper Stem Nut             | 208. Gland Follower       | 215. OS&Y Stem Assembly       |
| 202. OS&Y Handwheel             | 209. Gland                | 216. Bonnet Bolts (Not Shown) |
| 203. Anti-Friction Washer       | 210. Stud Bolt            | 217. Bonnet                   |
| 204. Yoke                       | 211. Stem Seal O-rings    | 218. Bonnet Gasket            |
| 205. Lower Stem Nut             | 212. Inner Bushing O-ring | 219. Body                     |
| 206. Gland Follower/Yoke Nut    | 213. OS&Y Bushing         |                               |
| 207. Gland Follower/Yoke Washer | 214. Outer Bushing O-ring |                               |

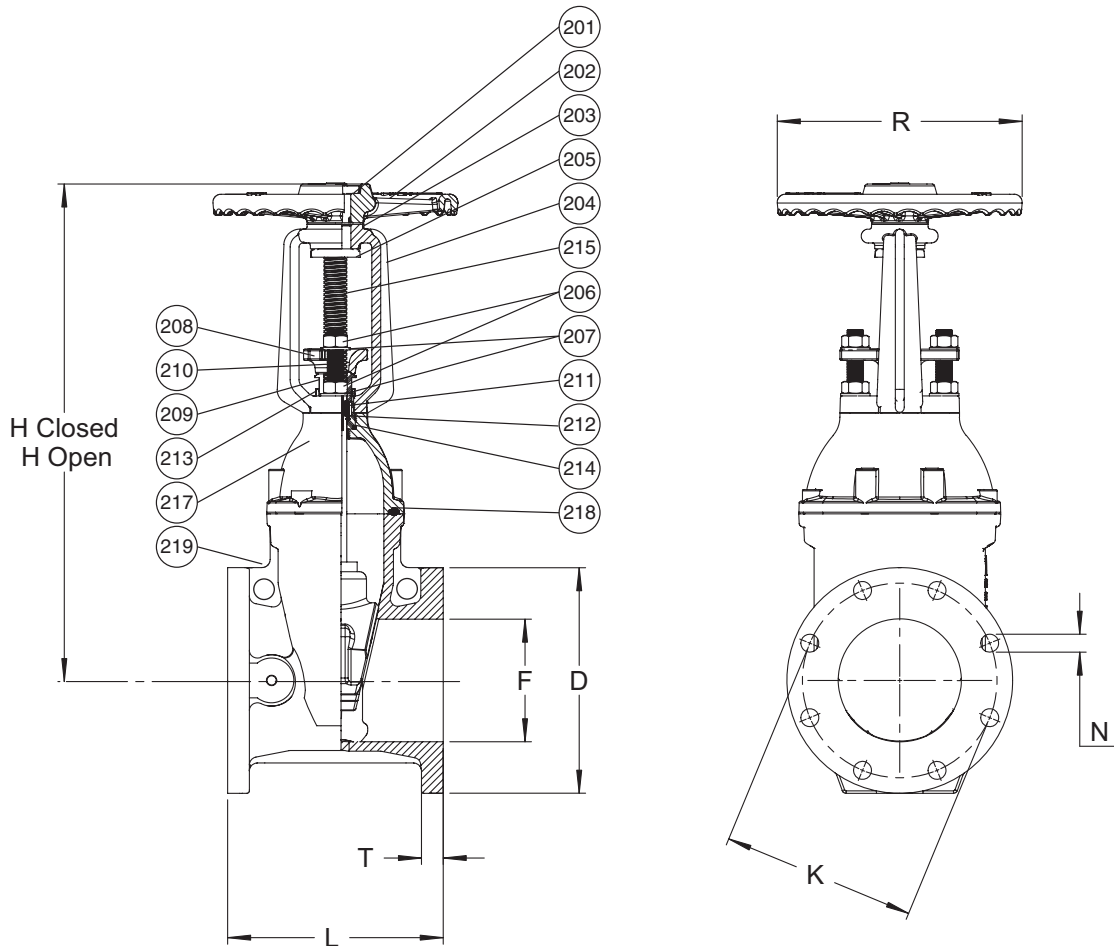

Ref. nos.	Size	D	F	H open	H closed	K	L	N	R	T	Flange holes	Turns to open	Wt. Lbs.
45-065-45X	2.5"	7.00"	2.50"	17.50"	15.00"	5.50"	7.50"	0.75"	7.00"	0.70"	4	17	42
45-080-45X	3"	7.50"	3.00"	18.63"	15.63"	6.00"	8.00"	0.75"	7.00"	0.79"	4	20	56
45-100-45X	4"	9.00"	4.00"	22.63"	18.63"	7.50"	9.00"	0.75"	10.00"	1.00"	8	21	84
45-150-45X	6"	11.00"	6.00"	31.00"	25.00"	9.50"	10.50"	0.88"	12.00"	1.06"	8	26	138
45-200-45X	8"	13.50"	8.00"	39.00"	31.00"	11.75"	11.50"	0.88"	14.00"	1.14"	8	35	211
45-250-45X	10"	16.00"	10.00"	46.80"	36.80"	14.25"	13.00"	1.00"	17.00"	1.22"	12	37	303
45-300-45X	12"	19.00"	12.00"	53.50"	41.50"	17.00"	14.00"	1.00"	17.00"	1.30"	12	44	431



36 Hudson Rd  
 Sudbury MA 01776



800-225-4616  
 www.tisales.com