

AMERICAN AVK RESILIENT SEATED GATE VALVE
250 PSI, Tested to AWWA C515 (NRS)
Flange Ends to ANSI B16.1 Class 125 - Valve Sizes 18" - 24"

55/5X
FLxFL

Use:

For water and neutral liquids to maximum 160°F.

Tests:

Hydraulic test to AWWA C515:

Shell Test: 500 PSI

Seat Test: 250 PSI

Operating Torque Test

Optional Materials:

Stem Bronze

Anti Friction Washer Polyamide

Bonnet Bolts Stainless steel - Stainless Steel - 316
 bolt sealed with hot melt

Gland Bolts, Lifting Eyes Stainless steel - Stainless Steel - 316

Options:

Handwheel, Electric Actuator, Bevel Gear, Spur Gear

Standard Materials:

Body, Bonnet, Gland Flange Ductile iron ASTM A536

Coating Electrostatically applied fusion-bonded epoxy-resin
 Meets or exceeds AWWA C550

Wrench Nut Ductile Iron ASTM A536
 - painted black for open left, red for open right.

Stem Standard: Stainless steel ASTM A582

Wedge Ductile iron ASTM A536
 encapsulated with EPDM-rubber compound

Wedge Nut, Thrust Collar Bronze

Bonnet Bolts, Gland Bolts Stainless Steel -304 sealed with hot melt

Lifting Eyes Stainless Steel -304

Bonnet Gasket, Wiper Ring, O-Ring Stem Seals, O-Ring Gland Seal ASTM D2000 Buna "N" nitrile rubber

Approvals:

NSF-61 (audited by UL)

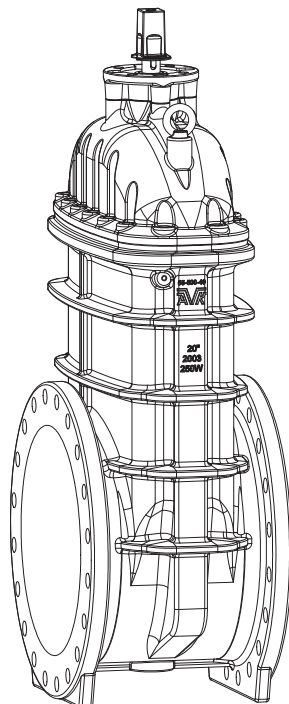

American AVK Company
 an ISO 9001-2000 registered company

DS S555X FLFL
 Subject to change without notice. (rev. 02/08)

AMERICAN AVK RESILIENT SEATED GATE VALVE
250 PSI, Tested to AWWA C515 (NRS)
Flange Ends to ANSI B16.1 Class 125 - Valve Sizes 18" - 24"

55/5X
FLxFL

Component List:

- | | | |
|------------------------|------------------------------|--------------------|
| 217. Bonnet | 228. Gland Flange | 233. Stem Rod |
| 218. Bonnet Gasket | 229. Gland O-Ring | 234. Thrust Collar |
| 219. Body | 230. Upper Stem Seal O-Rings | 237. Wedge |
| 226. Wiper Ring | 231. Stem Seal Bushing | 238. Lifting Eye |
| 227. Gland Flange Bolt | 232. Lower Stem Seal O-Ring | |

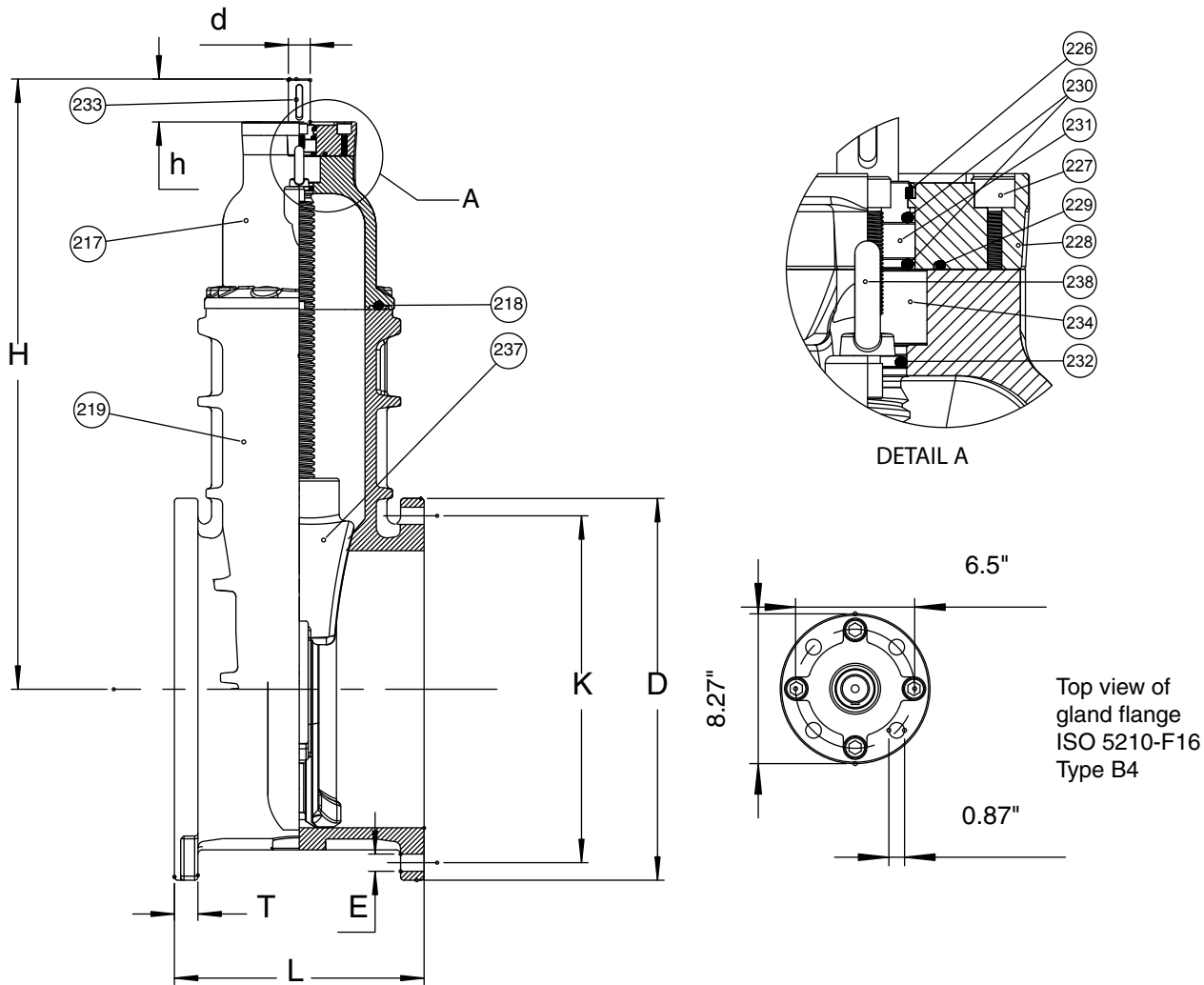

Ref. nos	Size	D	d	E	H	h	K	L	T	Flange Holes	Turns to open	Wt. Lbs.
55-450-5X	18"	25.00"	1.18"	1.25"	44.5"	3.13"	22.75"	17.00"	1.56"	16	42	1321
55-500-5X	20"	27.50"	1.18"	1.25"	44.5"	3.13"	25.00"	18.00"	1.70"	20	42	1408
55-600-5X	24"	32.00"	1.18"	1.38"	51.50"	3.13"	29.50"	20.00"	1.90"	20	51	1886



36 Hudson Rd
 Sudbury MA 01776



800-225-4616
 www.tisales.com