

**AMERICAN AVK RESILIENT SEATED DUCTILE IRON GATE VALVE**  
**250 PSI, Tested to AWWA C515 (NRS)**  
**Flanged Ends to ANSI B16.1 Class 125 - Valve sizes 2.5" - 12"**

**65/5X**  
**FLxFL**

**Use:**

For water and neutral liquids to maximum 160°F.

**Tests:**

Hydraulic test:

Shell Test: 500 PSI

Seat Test: 250 PSI

Operating Torque Test

**Optional Materials:**

Stem	Low zinc bronze ASTM B763
Anti Friction Washers	Polyamide
Bonnet Bolts	Option a): ASTM A164 zinc coated steel sealed with hot melt  Option b): Stainless Steel - 316 sealed with hot melt
Gland Bolts	Option a): ASTM A164 zinc coated steel Hexagon bolt  Option b): Stainless Steel - 316 Hexagon bolt

**Standard Materials:**

Body, Bonnet, Gland Flange, Wrench Nut	Ductile iron ASTM A536 (Wrench Nut-painted black for open left, red for open right)
Coating	VeloCorr™ Coating; fusion-bonded epoxy-resin process exceeds AWWA C550. Certified Holiday-Free, interior coating
Stem	Standard: Stainless steel ASTM A582
Wedge	Ductile iron ASTM A536 encapsulated with EPDM-rubber compound
Wedge Nut, Thrust Collar	Bronze
Bonnet Bolts	Stainless Steel - 304 sealed with hot melt
Gland Bolts	Stainless Steel - 304 Hexagon bolt
Bonnet Gasket, Wiper Ring, O-Ring Stem Seals, O-Ring Gland Seal	ASTM D2000 Buna "N" nitrile rubber

**Approvals:**

Certified to:  
ANSI/NSF 61, ANSI/NSF 372

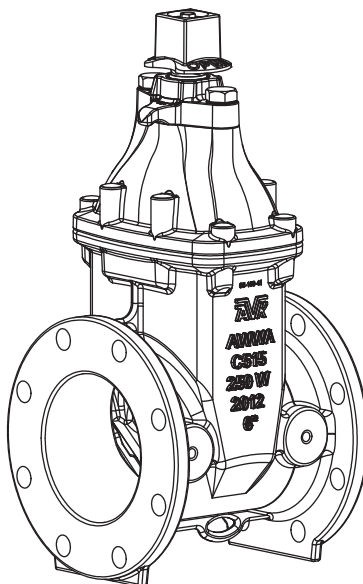

**AMERICAN AVK RESILIENT SEATED DUCTILE IRON GATE VALVE**  
**250 PSI, Tested to AWWA C515 (NRS)**  
**Flanged Ends to ANSI B 16.1 Class 125 - Valve sizes 2.5" - 12"**

**65/5X**  
**FLxFL**

**Component List:**

- |                    |                              |                             |
|--------------------|------------------------------|-----------------------------|
| 217. Bonnet        | 227. Gland Flange Bolt       | 232. Lower Stem Seal O-Ring |
| 218. Bonnet Gasket | 228. Gland Flange            | 233. NRS Stem               |
| 219. Body          | 229. Gland O-Ring            | 234. Thrust Collar          |
| 225. Wrench Nut    | 230. Upper Stem Seal O-Rings | 237. Wedge                  |
| 226. Wiper Ring    | 231. Stem Seal Bushing       |                             |

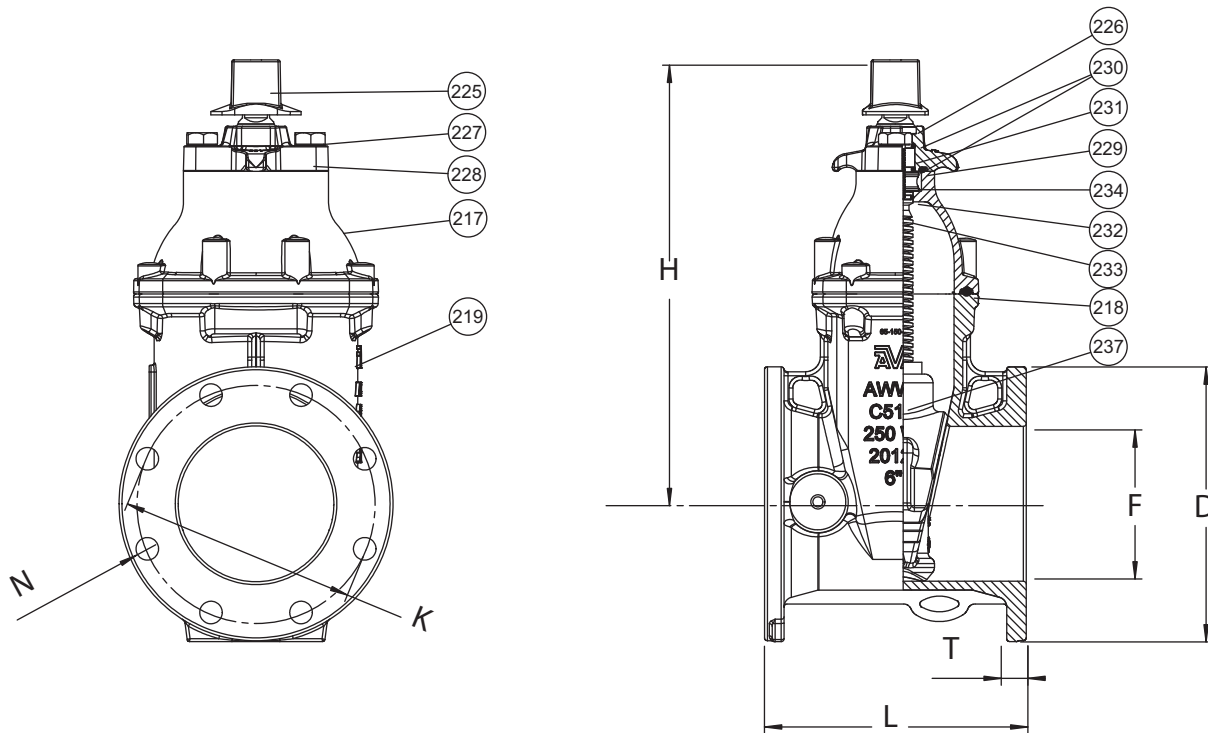

Ref No.	Size	D	F	H	K	L	N	T	Flange Holes	Turns to Open	Weight (lbs.)
65-065-5X	2.5"	7.00"	2.63"	12.09"	5.50"	7.50"	0.75"	0.69"	4	12.5	38
65-080-5X	3"	7.50"	3.13"	12.28"	6.00"	8.00"	0.75"	0.79"	4	15.5	46
65-100-5X	4"	9.00"	4.25"	13.82"	7.50"	9.00"	0.75"	0.79"	8	17.5	62
65-150-5X	6"	11.00"	6.25"	17.81"	9.50"	10.50"	0.88"	0.79"	8	24.5	103
65-200-5X	8"	13.50"	8.25"	21.83"	11.75"	11.50"	0.88"	0.91"	8	27.5	146
65-250-5X	10"	16.00"	10.25"	25.06"	14.25"	13.00"	1.00"	0.97"	12	34.5	224
65-300-5X	12"	19.00"	12.25"	27.96"	17.00"	14.00"	1.00"	1.04"	12	41.5	310



36 Hudson Rd  
 Sudbury MA 01776



800-225-4616  
 www.tisales.com