

AMERICAN AVK RESILIENT SEATED DUCTILE IRON GATE VALVE 65/HFN-WD
250 PSI, Tested to AWWA C515 (NRS) HYxFL
HYMAX GRIP® - Flanged Ends to ASME B 16.42 Class 150 - Valve sizes 4" - 12"

Use:

For water and neutral liquids to maximum 160°F.

Tests:

Hydraulic test to AWWA C509:

Shell Test: 500 PSI 3"-16"

Seat Test: 250 PSI 3"-16"

Operating Torque Test

Optional Materials:

Wedge Ductile iron ASTM A536
 encapsulated with NBR-rubber
 compound

Standard Materials:

Body, Bonnet, Gland Flange, Wrench Nut	Ductile iron ASTM A536 (Wrench Nut-painted black for open left, red for open right)
Coating	Electrostatically applied fusion- bonded epoxy-resin Meets or exceeds AWWA C550
Stem	Standard: Stainless steel 430F
Wedge	Ductile iron ASTM A536 encapsulated with EPDM-rubber compound
Wedge Nut, Thrust Collar	Bronze
Bonnet Bolts	Stainless Steel - 316 sealed with hot melt
Gland Bolts	Stainless Steel - 316 Hexagon bolt
Bonnet Gasket, Wiper Ring, O-Ring Stem Seals, O-Ring Gland Seal	ASTM D2000 Buna "N" nitrile rubber

Approvals:

Certified to: ANSI/NSF 61, ANSI/NSF 372

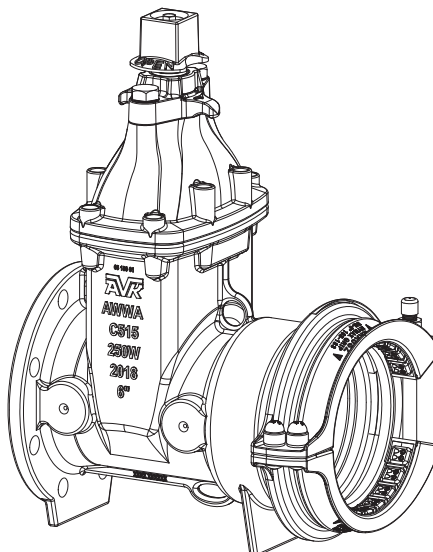

36 Hudson Rd 800-225-4616
 Sudbury MA 01776 www.tisales.com

AMERICAN AVK RESILIENT SEATED DUCTILE IRON GATE VALVE
250 PSI, Tested to AWWA C515 (NRS)
HYMAX GRIP® - Flanged Ends to ASME B 16.42 Class 150 - Valve sizes 4" - 12"

65/HFN-WD
HYxFL

Component List:

- | | | |
|--------------------|------------------------------|-----------------------------|
| 217. Bonnet | 227. Gland Flange Bolt | 232. Lower Stem Seal O-Ring |
| 218. Bonnet Gasket | 228. Gland Flange | 233. NRS Stem |
| 219. Body | 229. Gland O-Ring | 234. Thrust Collar |
| 225. Wrench Nut | 230. Upper Stem Seal O-Rings | 237. Wedge |
| 226. Wiper Ring | 231. Stem Seal Bushing | |

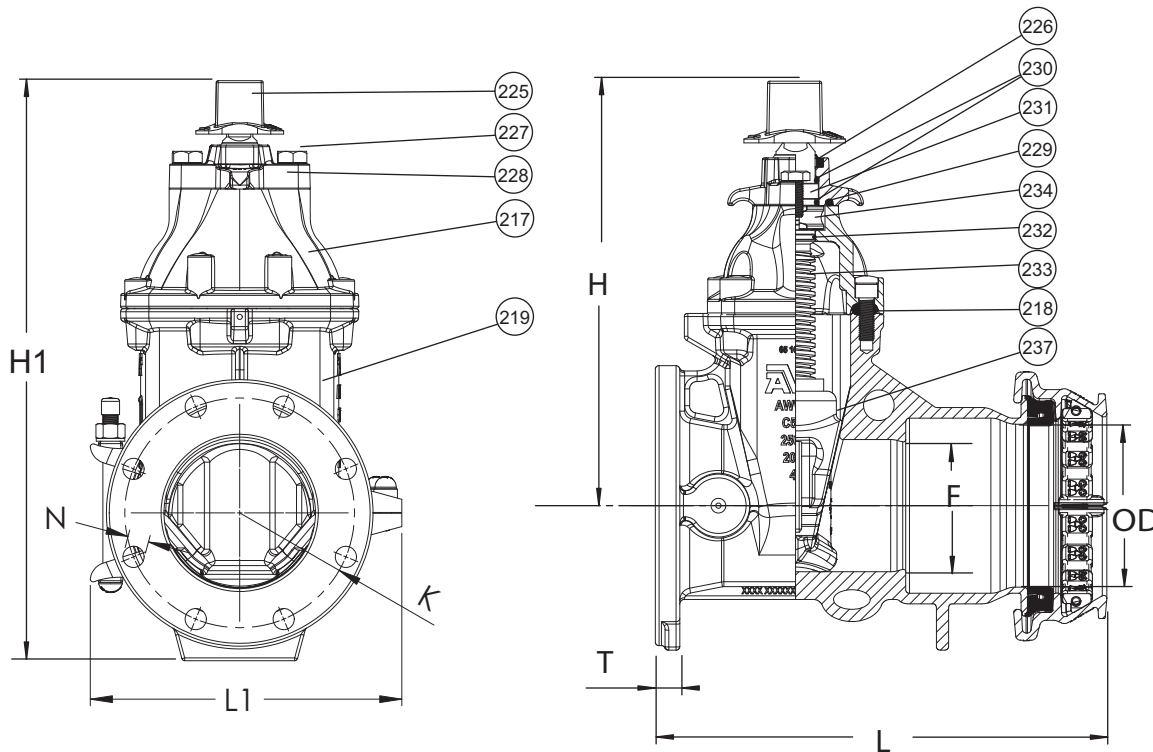

Ref No.	Size	Pipe OD		F	H	H1	K	L	L1	N	T	Flange Holes	Turns to Open	Weight (lbs.)
		Min/Max												
65-100-HFN-WD	4"	4.40"/5.10"		4.10"	13.82"	18.47"	7.50"	14.74"	10.60"	0.75"	0.79"	8	17	73
65-150-HFN-WD	6"	6.50"/7.20"		6.18"	17.81"	23.91"	9.50"	16.15"	12.90"	0.88"	0.79"	8	21	119
65-200-HFN-WD	8"	8.50"/9.40"		8.19"	21.83"	29.31"	11.75"	17.63"	15.70"	0.88"	0.91"	8	27	170
65-250-HFN-WD	10"	10.65"/11.55"		10.25"	25.06"	33.72"	14.25"	18.91"	18.20"	1.00"	0.97"	12	34	253
65-300-HFN-WD	12"	12.68"/13.39"		12.25"	27.96"	37.41"	17.00"	19.67"	19.80"	1.00"	1.04"	12	41	331

Min. Coupling Torque - Ft. Lbs.

- | | |
|--------|-------|
| 4" | - 90 |
| 6" | - 110 |
| 8"-12" | - 200 |



36 Hudson Rd
 Sudbury MA 01776



800-225-4616
www.tisales.com