



A PRODUCT SHEET OF NEPTUNE TECHNOLOGY GROUP

# T-10<sup>®</sup> METER

SIZES: 1 ½" and 2"



Every Neptune<sup>®</sup> T-10<sup>®</sup> water meter meets or exceeds the latest AWWA C700 Standard. Its nutating disc, positive displacement principle has been time-proven for accuracy and dependability since 1892, ensuring maximum utility revenue.

The T-10 water meter consists of three major assemblies: a register, a lead free, high-copper alloy maincase, and a nutating disc measuring chamber.

The T-10 meter is available with a variety of register types. For reading convenience, the register can be mounted in one of four positions on the meter.

The corrosion-resistant maincase will withstand harsh service conditions: internal water pressure, rough handling, and in-line piping stress.

The innovative floating chamber design of the nutating disc measuring element protects the chamber from frost damage while the unique chamber seal extends the low-flow accuracy by sealing the chamber outlet port to the maincase outlet port. The nutating disc measuring element utilizes corrosion-resistant materials throughout and a thrust roller to minimize wear.

## KEY FEATURES

### Register

- Magnetic-driven, low-torque registration ensures accuracy
- Impact-resistant register
- High-resolution, low-flow leak detection
- Bayonet-style register mount allows in-line serviceability
- Tamperproof seal pin deters theft
- Date of manufacture, size, and model stamped on dial face

### Lead Free Maincase

- Made from lead free, high-copper alloy
- NSF/ANSI 61 Certified
- NSF/ANSI 372 Certified
- Lifetime guarantee
- Resists internal pressure stresses and external damage
- Handles in-line piping variations and stresses
- Provides residual value vs. plastic
- Electrical grounding continuity

### Nutating Disc Measuring Chamber

- Positive displacement
- Widest effective flow range for maximum revenue
- Proprietary polymer materials maximize long-term accuracy
- Floating chamber design is unaffected by in-line piping stresses

### 1 1/2" Accuracy

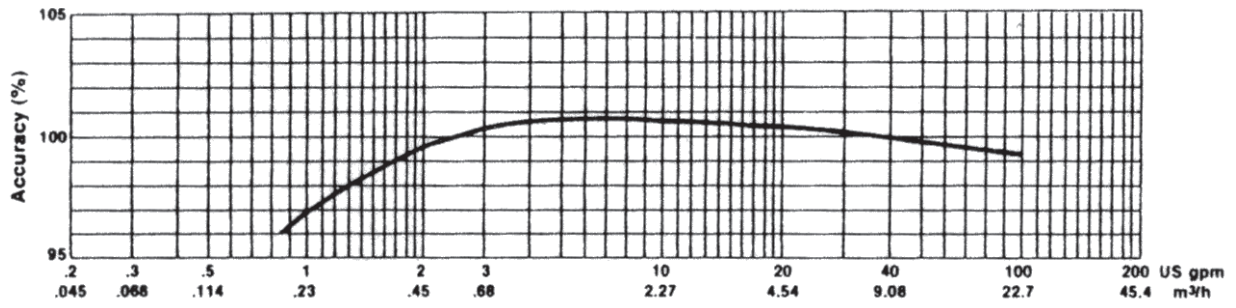

### 2" Accuracy

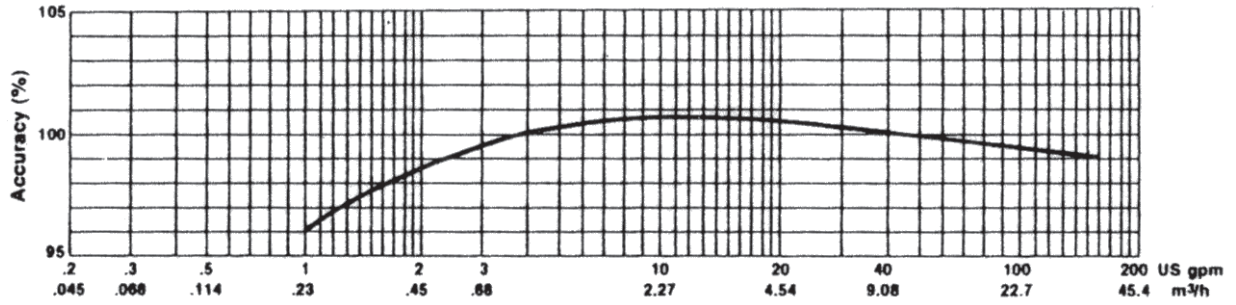

### 1 1/2" Pressure Loss

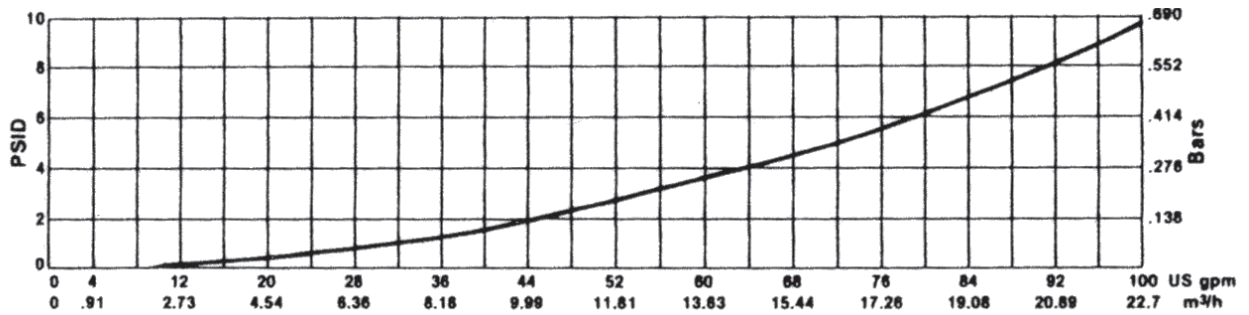

### 2" Pressure Loss

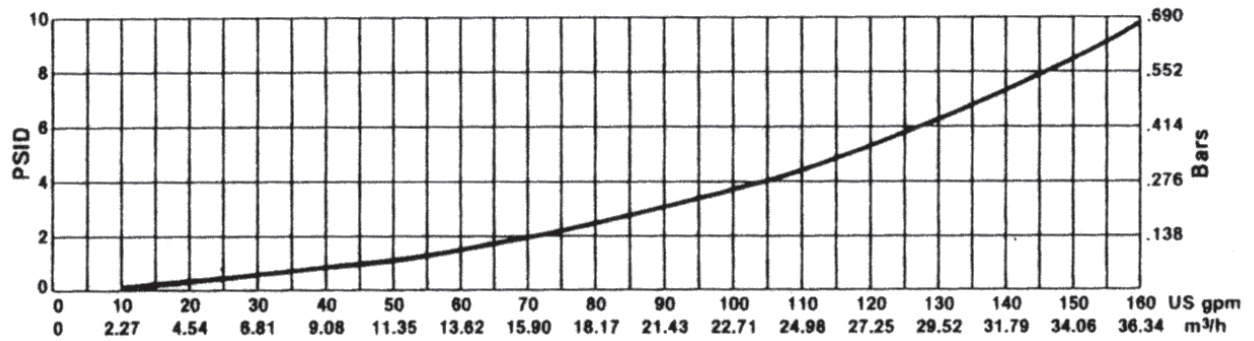

*These charts show typical meter performance. Individual results may vary.*

## Operating Characteristics

Meter Size	Normal Operating Range @100% Accuracy (±1.5%)	AWWA Standard	Low Flow @ 95% Accuracy
1 1/2"	2 to 100 US gpm 0.46 to 22.73 m <sup>3</sup> /h	5 to 100 US gpm 1.1 to 22.7 m <sup>3</sup> /h	3/4 US gpm 0.17 m <sup>3</sup> /h
2"	2 1/2 to 160 US gpm 0.57 to 36.36 m <sup>3</sup> /h	8 to 160 US gpm 1.8 to 36.3 m <sup>3</sup> /h	1 US gpm 0.23 m <sup>3</sup> /h

## Dimensions

Meter Size	A in/mm	B in/mm	C-Std. in/mm	C-ARB in/mm	C-E-CODER®) R900i™ or ProCoder™) R900i™	D-Threads per inch	D-Thread Type	E in/mm	Weight lbs/kg
1 1/2" Screw End	12 5/8 321	8 1/16 205	8 1/8 206	8 13/16 220.3	8 3/8 213	11 1/2	1 1/2 NPT	2 9/16 65	31 14.1
1 1/2" Flanged End	13 330	8 1/16 205	8 1/8 206	8 13/16 220.3	8 3/8 213	—	—	2 9/16 65	35 15.9
2" Screw End	15 1/4 387	9 7/16 240	9 5/16 237	9 15/16 248.4	9 1/2 241	11 1/2	2" NPT	3 1/8 79	40 18.1
2" Flanged End	17 432	9 7/16 240	9 5/16 237	9 15/16 248.4	9 1/2 241	—	—	3 1/8 79	44 20.0

T-10 With Standard Register

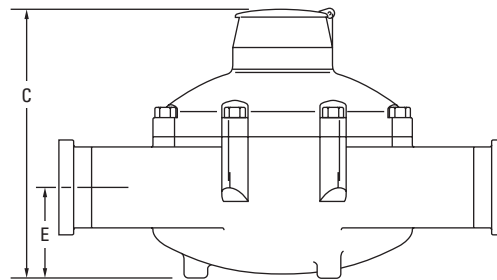
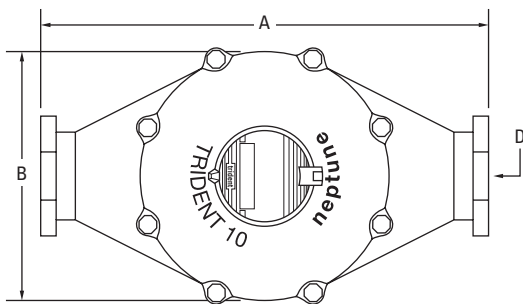

T-10 With E-CODER®)R900i™ or ProCoder™)R900i™ Pit Register

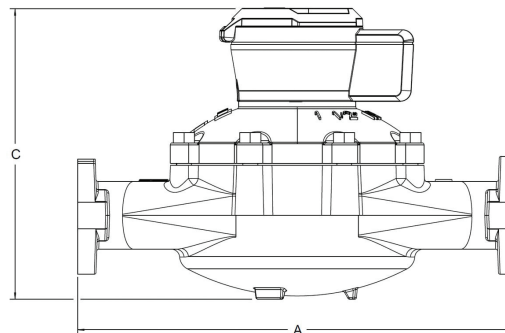
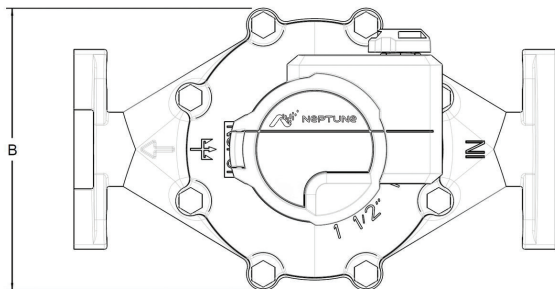

## Guaranteed Compatibility

All T-10 meters are guaranteed adaptable to our ProRead™, ProCoder™, E-CODER®, E-CODER®)R900i™, E-CODER®)R450i™, ProCoder™)R900i™, TRICON®/S, TRICON/E®3, and Neptune Utility Systems™ without removing the meter from service.

## Registration

ProRead Registration (per sweep hand revolution)		1 ½"	2"
100	US Gallons	✓	✓
100	Imperial Gallons	✓	✓
10	Cubic Feet	✓	✓
1	Cubic Metre		✓
.01	Cubic Metre	✓	
Register Capacity ProRead, ProCoder, and E-CODER		1 ½"	2"
100,000,000	US Gallons	✓	✓
100,000,000	Imperial Gallons	✓	✓
10,000,000	Cubic Feet	✓	✓
100,000	Cubic Metres	✓*	
1,000,000	Cubic Metres	✓**	✓
E-CODER High Resolution (8-digit reading)		1 ½"	2"
1	US Gallons	✓	✓
1	Imperial Gallons	✓	✓
0.1	Cubic Feet	✓	✓
0.01	Cubic Metres		✓
0.001	Cubic Metres	✓	
ProCoder High Resolution (8-digit reading)		1 ½"	2"
1	US Gallons	✓	✓
1	Imperial Gallons	✓	✓
0.1	Cubic Feet	✓	✓
0.01	Cubic Metres	✓	✓

\*ProRead and E-CODER only \*\*ProCoder only

## Specifications

### Certification

- NSF/ANSI 61, NSF/ANSI 372

### Application

- Cold water measurement of flow in one direction

### Maximum Operating Water Pressure

- 150 psi (1,034 kPa)

### Maximum Operating Water Temperature

- 80°F

### Measuring Chamber

- Nutating disc technology design made from proprietary synthetic polymer

## Options

### Sizes

- 1 ½" flanged or threaded end
- 2" flanged or threaded end

### Units of Measure

- U.S. gallons, imperial gallons, cubic feet, cubic metres

### Register Types

- ProCoder, E-CODER, E-CODER)R900i, ProCoder)R900i
- Reclaim

### Measuring Chamber

- Synthetic polymer

### Companion Flanges

- Lead free, high-copper alloy

### Environmental Conditions

- Operating temperature: +33°F to +149°F (0°C to +65°C)
- Storage temperature: +33°F to +158°F (0°C to +70°C)

### Test Ports

- 1" (optional)

## Warranty

Neptune provides a limited warranty for performance, materials, and workmanship. See warranty statement for details.



36 Hudson Rd  
Sudbury, MA 01776

800.225.4616

www.tisales.com



Metering Systems Support  
978.261.7683