

# SUBMITTAL INFORMATION

## Adapter Flange - (UFA420-C-x series)

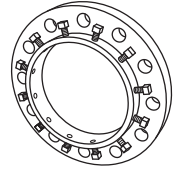

### UNI-FLANGE® SERIES 420 ADAPTER FLANGE FOR DUCTILE IRON PIPE

Set Screw - AISI 4140 Steel;  
Tensile 190,000 psi minimum.  
Heat treated to 35-39 Rockwell  
C, and zinc plated for corrosion  
resistance.

Flange - Ductile Iron per  
ASTM A536, Grade 65-45-  
12. Drilling to AWWA Class F,  
ANSI B16.1 (250 lb. cast iron),  
or ANSI B16.5 (300 lb. steel)

Finish: Shop coat

Color Code: Red for ductile  
iron applications

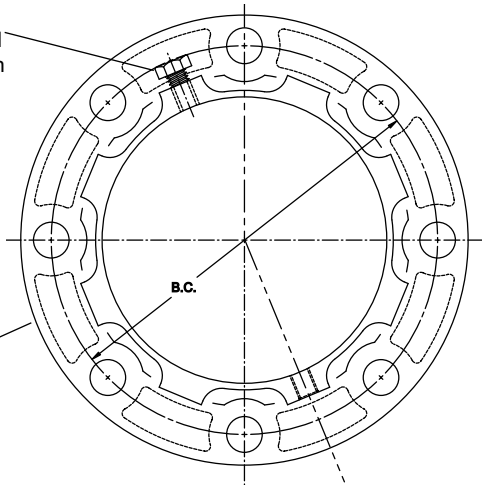

Gasket - SBR (Buna-S)  
mechanical joint gasket

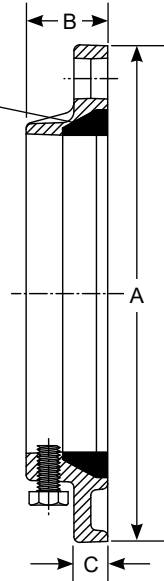

NOM. PIPE SIZE	DUCTILE IRON PIPE		APPROX. WT. LBS.	PRESSURE RATING PSI	SET SCREWS		FLANGE			NO. OF BOLT HOLES	BOLT CIRCLE DIA.	✓ SUBMITTED ITEM(S)
	OD (IN.)	CATALOG No.			NUMBER	SIZE	OD A	APPROX. THICKNESS B	APPROX. THICKNESS C			
2"	2.50	UFA420-C-2	9	400	8	1/2"x1"	6-1/2"	2-1/4"	1-7/64"	8	5"	
3"	3.96	UFA420-C-3	13	400	8	1/2"x1"	8-1/4"	2-3/8"	1-11/64"	8	6-5/8"	
4"	4.80	UFA420-C-4	21	400	8	1/2"x1"	10"	2-7/16"	1-1/4"	8	7-7/8"	
6"	6.90	UFA420-C-6	38	400	12	5/8"x1-1/4"	12-1/2"	2-9/16"	1-7/16"	12	10-5/8"	
8"	9.05	UFA420-C-8	46	400	12	5/8"x1-1/4"	15"	2-5/8"	1-5/8"	12	13"	
10"	11.10	UFA420-C-10	74	400	16	5/8"x1-1/4"	17-1/2"	3"	1-7/8"	16	15-1/4"	
12"	13.20	UFA420-C-12	91	400	16	5/8"x1-1/4"	20-1/2"	3-1/8"	2"	16	17-3/4"	

### FEATURES

- Restraint is provided by a set screw locking device similar to that used in mechanical joint retainer glands
- The gasket is an SBR (Buna-S) mechanical joint gasket. Available in optional EPDM or NBR (Buna-N) gasket
- Designed for ease of on-site installation. Eliminates bolt hole alignment problems and allows for pipe deflection
- Series 420 adapter flanges are not recommended for use on PVC pipe
- Optional Uni-Torque set screws are available for use with Series 420 adapter flanges for ductile iron pipe, class 52-56. To order, add "-UT" to the catalog number. Example: UFA420-C-6-UT
- Uni-Torque set screws should not be used on steel pipe thinner than schedule 40 or ductile iron thinner than class 52
- Optional EPDM gasket is available. To order, add "-EPDM" to end of catalog number. Example: UFA420-C-6-EPDM
- Optional stainless steel set screws, type 410 per ASTM F593, are available for Series 400 adapter flanges. To order, add "-SS" to the catalog number. Example: UFA420-C-6-SS

The Ford Meter Box Company considers the information in this submittal form to be correct at the time of publication. Item and option availability, including specifications, are subject to change without notice. Please verify that your product information is current. Our standard warranty applies.



**The Ford Meter Box Company, Inc.**  
P.O. Box 443, Wabash, Indiana U.S.A. 46992-0443  
Phone: 260-563-3171 / Fax: 800-826-3487  
Overseas Fax: 260-563-0167  
www.fordmeterbox.com

02/19/20

Submitted By:

**Ti SALES**

36 Hudson Rd  
Sudbury MA 01776



800-225-4616  
www.tisales.com