



# Model XT

## Water Thermal Expansion Tank

### Application

Designed for installation on potable water lines between the backflow preventer or pressure reducing valve and the water heater to protect against water thermal expansion. When system pressure increases, water enters the tank's polypropylene lined water chamber which expands a diaphragm into a pre-charged air chamber, keeping system pressure below the relief valve setting.

### Standards Compliance

- IAPMO® Listed
- Water Quality Association - Certified to NSF/ANSI 61 & 372\*  
\*(0.25% MAX. WEIGHTED AVERAGE LEAD CONTENT)

### Materials

Outer shell	Carbon Steel
Coatings	Epoxy finish (outer shell)
Connection	Stainless Steel
Liner	Polypropylene
Diaphragm	Butyl Rubber

### Features

Sizes (liters):	8, 18, 35
Maximum Supply Pressure:	80 PSI
End connections	Threaded NPT ANSI B1.20.1
Factory Pre-charge (adjustable)	40 PSI

**Note:** Model XT tanks are certified to NSF 61 domestic hot, but are suitable for temperatures up to 200° F.

**Note:** Not suitable for use on fire sprinkler systems as required by NFPA 13 or 13D.



LEAD FREE



NSF/ANSI 61  
NSF/ANSI 372

### Accessories

- NR3XL - Water pressure reducing valve
- TP1100A - Temperature & pressure relief valve
- P1000AXL - Pressure relief valve
- P3000CI - Pressure relief valve
- P3000BR - Pressure relief valve
- 975XL2 - Reduced pressure backflow preventer
- VR10XL - Vacuum relief valve

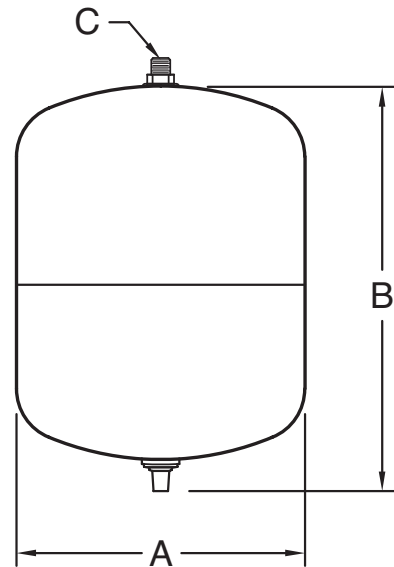

### Dimensions & Weights (do not include pkg.)

TANK DIMENSIONS AND CAPACITIES								
MODEL NUMBER	MAXIMUM SUPPLY PRESSURE psi	TANK VOLUME (gallons)	MAXIMUM ACCEPTANCE VOLUME (gallons)	FACTORY PRE-CHARGE psi	DIMENSIONS			WEIGHT lbs.
					DIAMETER A	HEIGHT B	SYSTEM CONNECTION C	
XT-8	80	2.1	1.0	40	8	10 1/2	3/4NPT	5.5
XT-18	80	4.8	2.4	40	11	13 1/2	3/4 NPT	10
XT-35	80	9.0	4.25	40	12 1/2	17 1/4	3/4 NPT	15.5

### Sizing Chart

Supply Pressure (PSIG)	Tank Pre-Charged (PSIG)	WATER HEATER CAPACITY (U.S. gal)										
		20	30	40	50	60	80	100	120	150	175	200
40	40	8	8	8	8	8	18	18	18	35	35	35
50	50	8	8	8	8	8	18	18	18	35	35	35
55	55	8	8	8	8	8	18	18	18	35	35	35
60	60	8	8	8	8	18	18	18	18	35	35	35
70	70	8	8	8	18	18	18	18	35	35	35	35
80	80	8	8	18	18	18	18	35	35	35	35	35

Based upon 100° temperature rise (40°F to 140°F) and 150 PSI maximum allowable tank pressure

### Typical Installation

Local codes shall govern installation requirements. Unless otherwise specified, the assembly shall be mounted on the cold water supply and at least 18" from the cold water inlet to the heater. **Note:** Pre-charge should be adjusted to match incoming water pressure (adjust pre-charge with no water pressure in tank).

Maximum allowable pre-charge in this expansion tank is 80 PSI. A properly sized pressure relief valve set at a maximum of 150 PSI must also be installed in the system. For installations that have a supply pressure above 80 PSI, a properly sized pressure reducing valve should be installed on the system.

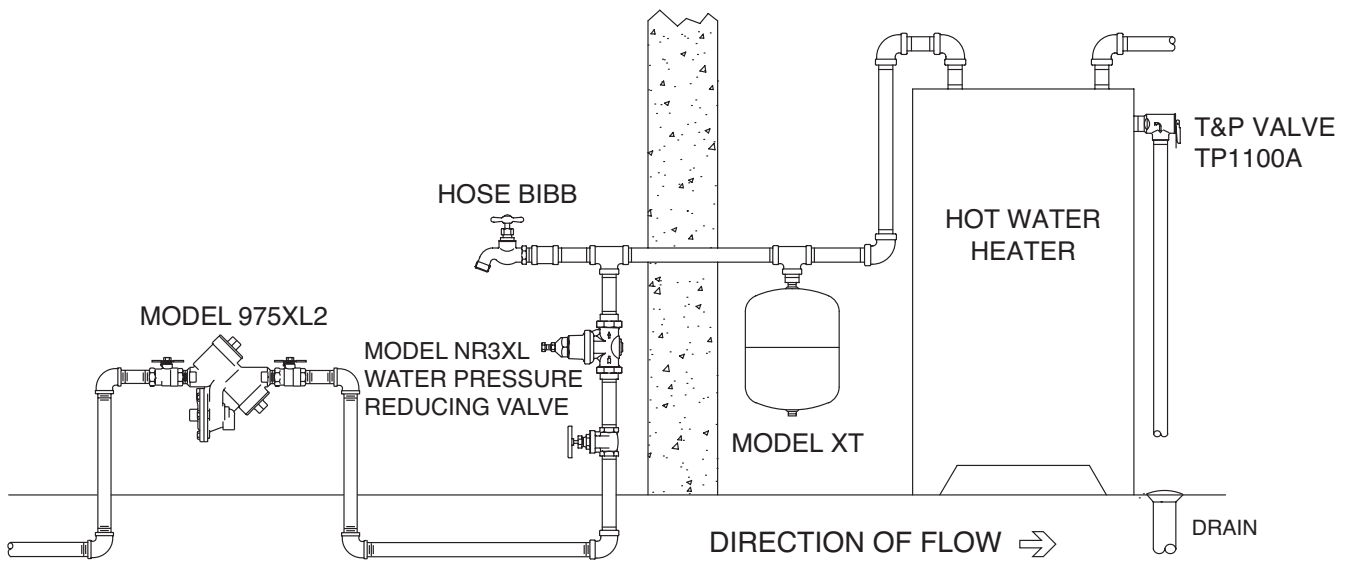

Model XT Installation

### Specifications

The Water Thermal Expansion Tank outer shell shall be carbon steel. The diaphragm shall be FDA approved butyl rubber and, the water chamber shall be polypropylene lined to preclude water contact with the shell interior. The assembly shall have a NPT Stainless steel system connection and a 0.301"-32 charging valve connection (standard tire valve) to facilitate the on-site charging of the tank to meet system requirements. The tank shall be IAPMO® listed and certified to NSF/ANSI 61 & 372. The Water Thermal Expansion Tank shall be a ZURN WILKINS Model XT.



36 Hudson Rd  
Sudbury MA 01776



800-225-4616  
www.tisales.com