

SUBMITTAL INFORMATION

Inverted Key Curb Stop - (Z41-xxx-NL style)

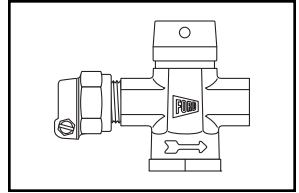

PACK JOINT FOR COPPER OR PLASTIC TUBING (CTS) INLET BY FEMALE IRON PIPE THREAD OUTLET

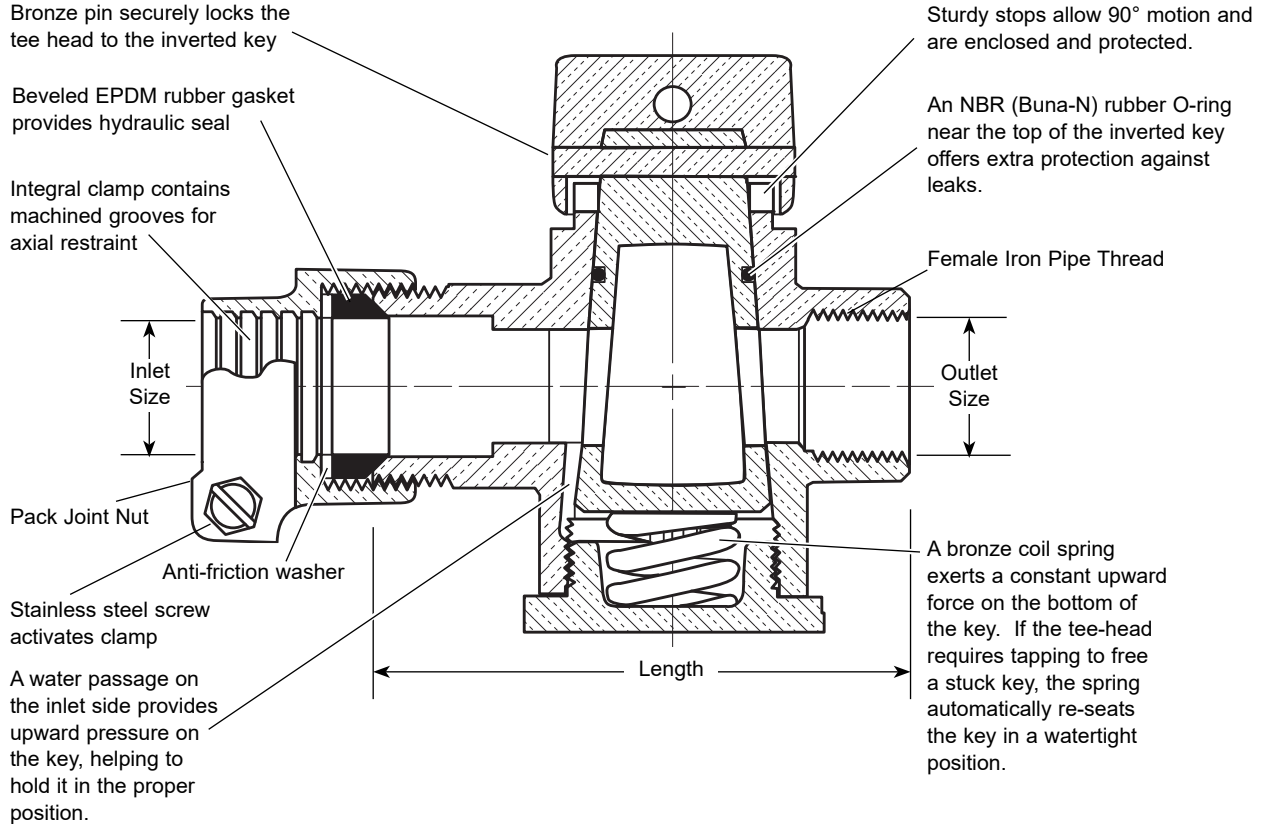

VALVE SIZE	INLET SIZE	OUTLET SIZE	LENGTH	APPROX. WT. LBS	PART NUMBER	✓ SUBMITTED ITEM(S)
3/4"	3/4"	3/4"	3-13/16"	2.4	Z41-333-NL	
1"	1"	1"	5-11/16"	4.1	Z41-444-NL	

Note: Ford recommends using insert stiffeners with plastic pipe or tubing

FEATURES

- All brass that comes in contact with potable water conforms to AWWA Standard C800 (ASTM B584, UNS C89833)
 - The product has the letters "NL" cast into the main body for lead-free identification
 - Certified to NSF/ANSI Standard 61 and NSF/ANSI Standard 372 where applicable
 - Brass components that do not come in contact with potable water conform to AWWA Standard C800 (ASTM B62 and ASTM B584, UNS C83600, 85-5-5-5)
 - Hole for attaching curb box rod or handle is provided in tee-head
 - 100 PSI working pressure
- Optional full 360° tee-head rotation.** Add "R" to end of part number

The Ford Meter Box Company considers the information in this submittal form to be correct at the time of publication. Item and option availability, including specifications, are subject to change without notice. Please verify that your product information is current. Our standard warranty applies.



The Ford Meter Box Company, Inc.
 P.O. Box 443, Wabash, Indiana U.S.A. 46992-0443
 Phone: 260-563-3171 / Fax: 800-826-3487
 Overseas Fax: 260-563-0167
 www.fordmeterbox.com

07/08/21

Submitted By:



36 Hudson Rd
 Sudbury MA 01776



800-225-4616
 www.tisales.com