

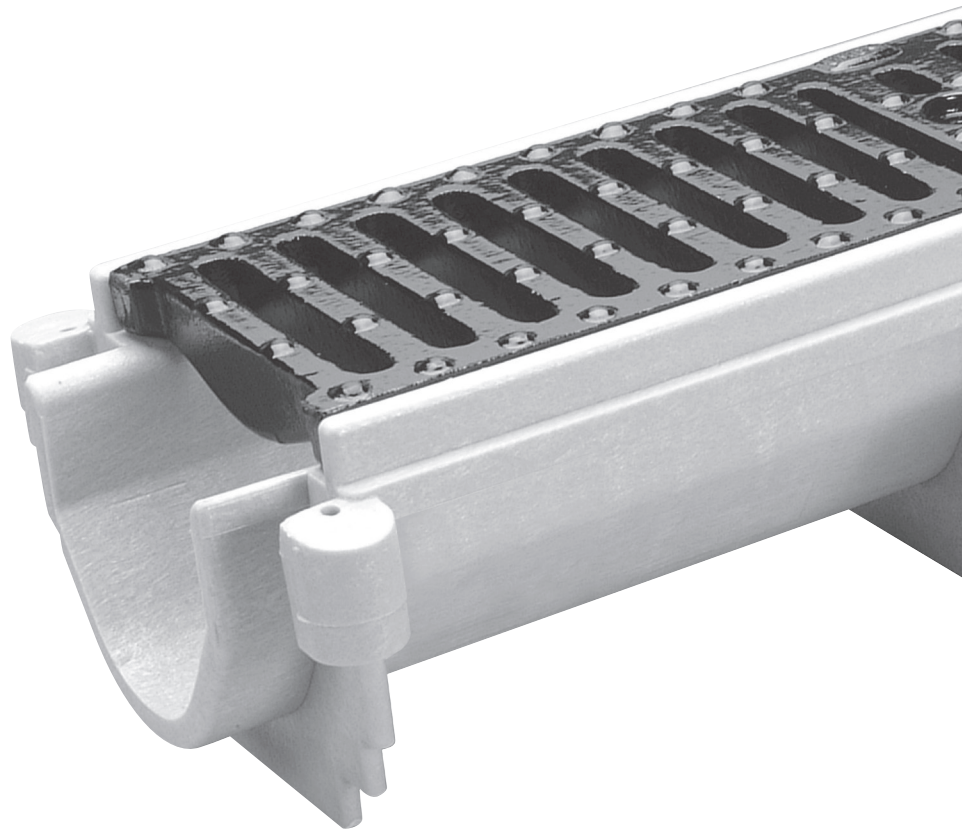

LINEAR DRAINAGE

# Z886 Perma-Trench

*6" Perma-Trench Installation Instructions*



36 Hudson Rd  
Sudbury MA 01776



800-225-4616  
[www.tisales.com](http://www.tisales.com)

1.855.ONE.ZURN | [ZURN.COM](http://ZURN.COM)



# Z886 Accessories

## 6" [152MM] WIDE TRENCH DRAIN SYSTEM

Below are the components of the Z886 trench drain typical to an installation. Check your order to verify you have all components particular to your job before beginning your installation. Contact customer service at 855-ONE-ZURN should additional material be required.

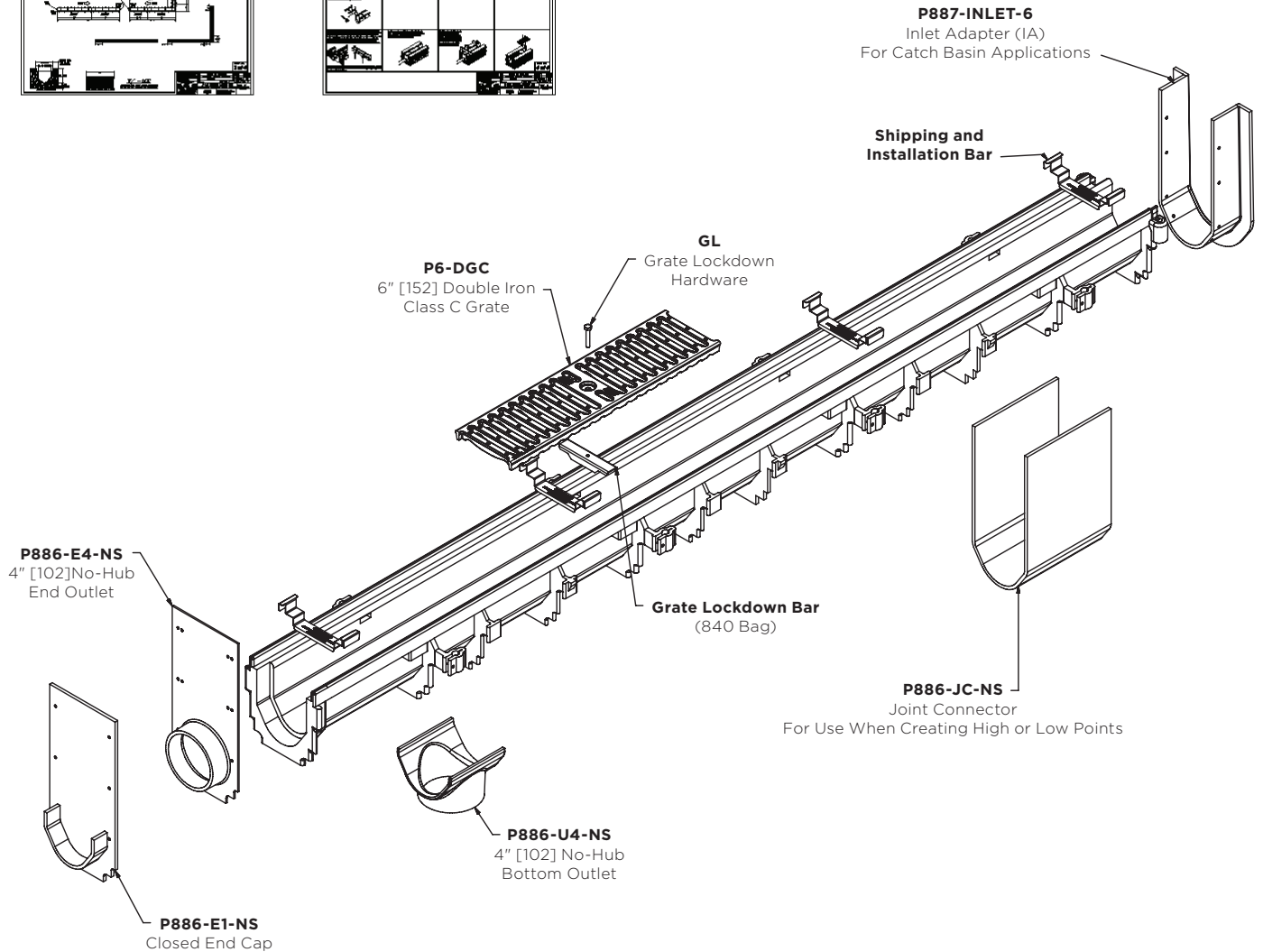
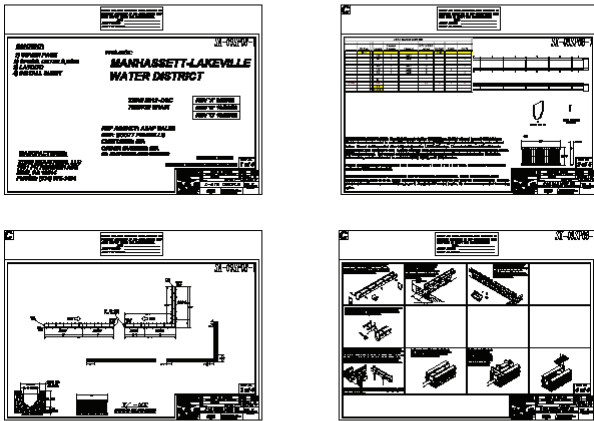

# Z886 Tools Required



Tape Measure

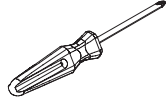

Phillips Head Screwdriver

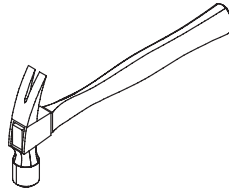

Hammer

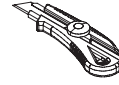

Utility Knife

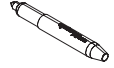

Marker

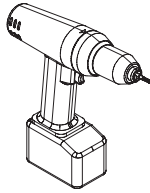

Cordless Drill

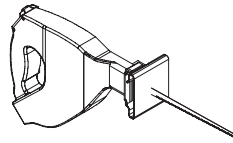

Reciprocating Saw



Ear Protection



Safety Glasses

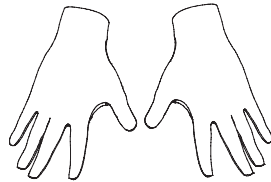

Gloves



Hole Saw

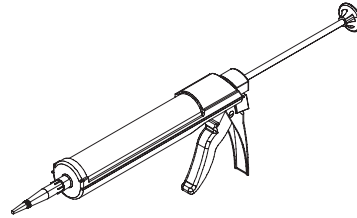

Caulk Gun

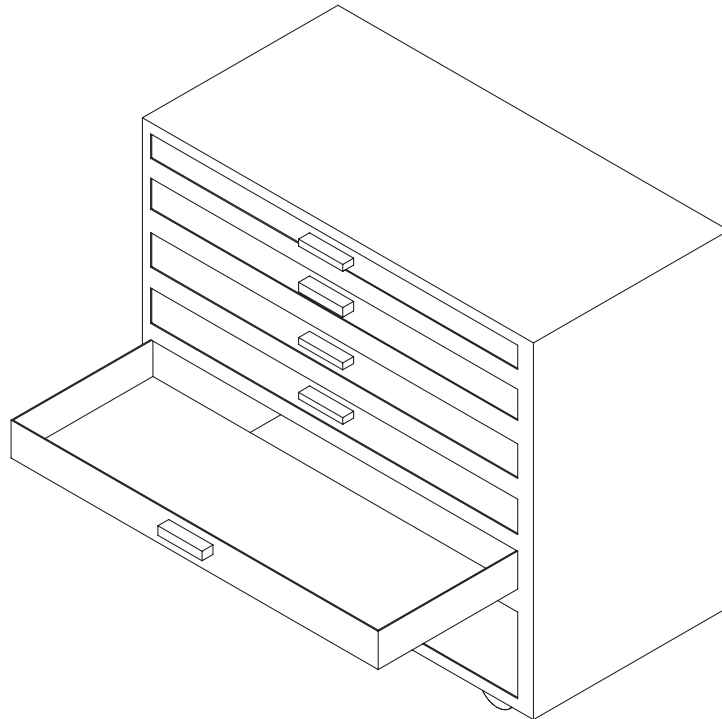



## Z886 Encasement

A 4" [102] new concrete encasement is minimum. Guidelines for reinforcing an encasement would be to use the same thick-ness and reinforcing used in the surrounding concrete slab. Concrete must be vibrated to remove air voids in encasement, especially under the frame rails.

Specifying engineer is responsible for concrete encasement and reinforcing based upon application and local codes.

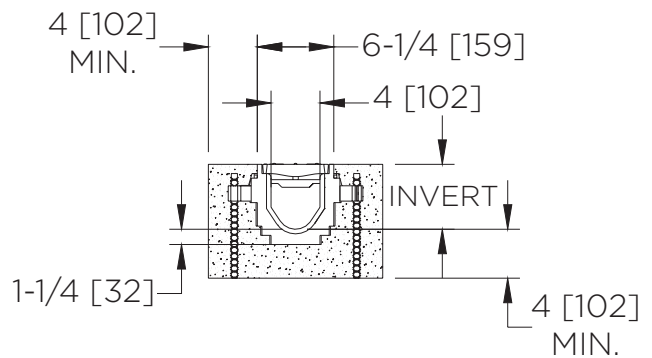

## Excavation

Trench excavation must include the minimum of 4" [102] on both sides and underneath or the slab thickness surrounding the trench. Soft and/or shifting soil substrates may cause cracking of the concrete and consequent movement of the trench. It is critical that the concrete be poured on an adequate foundation. Verify depth of trench excavation to allow for the same thickness of concrete under and beside the trench as the surrounding slab thickness.

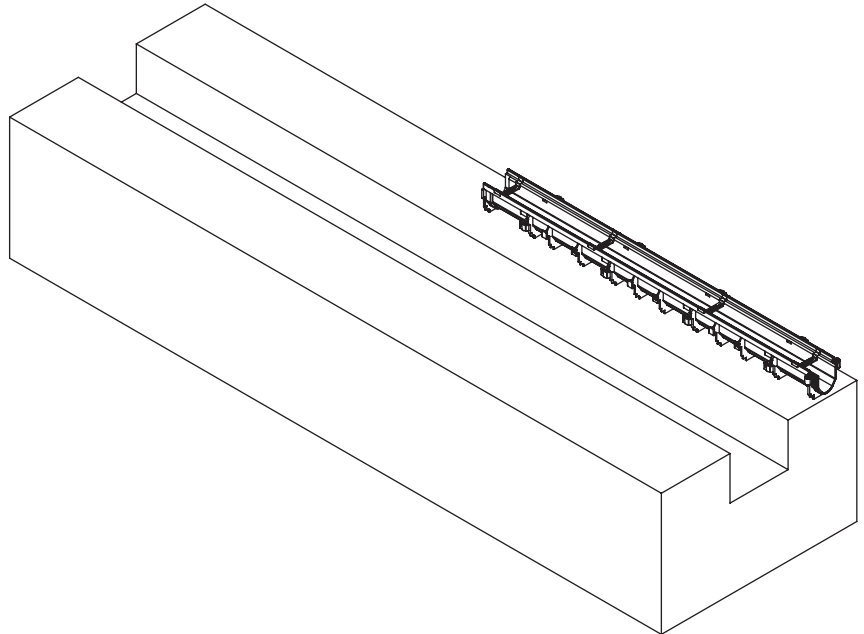

# Z886 Layout

Upon completion of the excavation, the channel should be placed in numeric order alongside the excavation according to the job layout. Each trench section has a trench identification number and flow direction indicating its sequence within the system. It is best to work from the deep or outlet end to the shallow. Grates are not installed at this time.

Four (4) shipping/installation bars per channel; recommended spacing is approximately 3"-6" [76-152] from end of rail for end pieces and 26"-29" [660-737] from end of rail for center pieces. All shipping/installation bar locations are approximate.

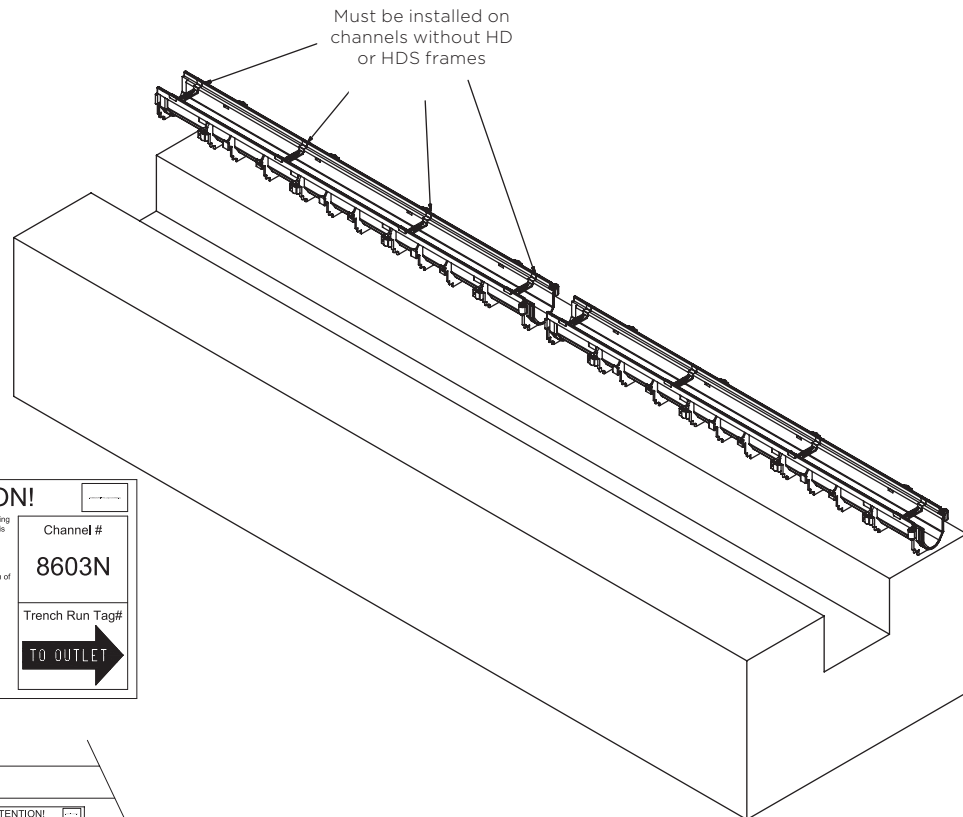
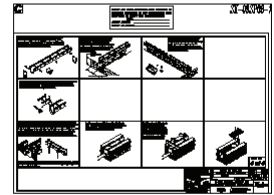
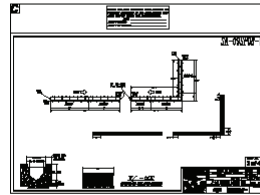
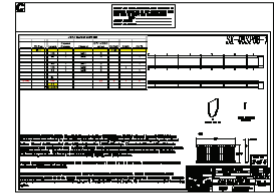
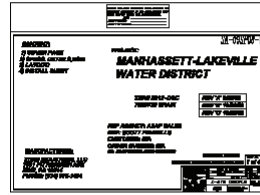

**ZURN** **ATTENTION!**

- Minimum of 4 installation shipping bars are to be used during concrete pour and removed during finishing (unless frame is attached)
- Trench shall not be used as an expansion joint
- Verify location and elevations prior to pouring concrete
- Set trench 116" below finish grade
- Encase in concrete per engineering specification (minimum of 4" complete encasement, sides and bottom)
- Standard concrete practices with expansion and crack induction joints per codes and standards
- Internal bracing is required with sidewalls
- Multiple lifts of concrete may be used
- Vibrate concrete adequately
- Conveys fluid up to 140°F
- Max temperature variation of 80°F
- Standard 1x6 lumber in the grate seat during the pour if desired
- Visit Zurn.com for more details

Channel #  
**8603N**

Trench Run Tag#  
**TO OUTLET** →

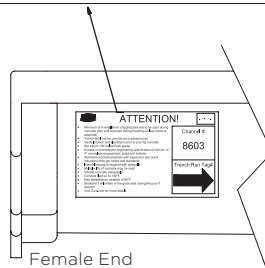



# Z886 End Outlet Connection Options

- 1 When installing end cap or end outlet, remove by cutting with saw the 1-1/4" [32] male overlap connection as shown.

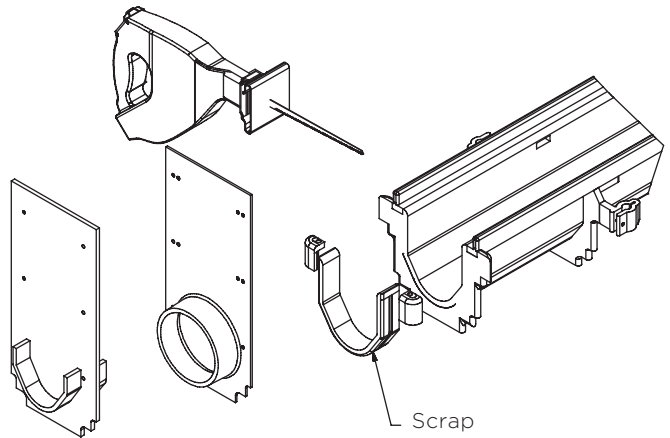

- 2 Once overlap is removed, trim end cap/end outlet to desired height.

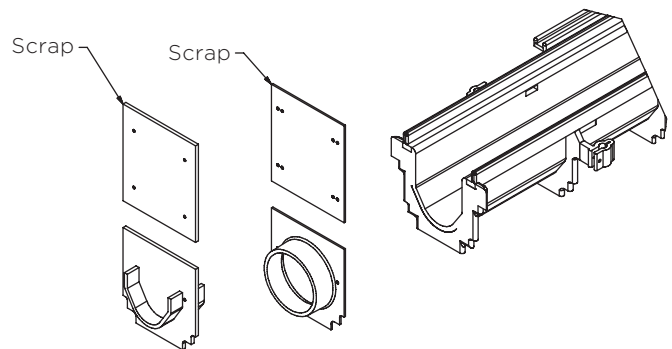

- 3 Attach end outlet or end cap to the channel with hardware provided.

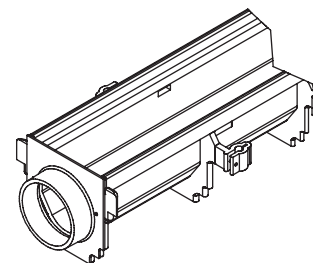

## ATTACHING END CAPS AND OUTLETS

Make sure all overlaps on trench are trimmed off prior to installing the end caps to ensure the finish installation has a frame above the trench channel. This ensures each trench will have a grate on it.

# Z886 Bottom Outlet Connection Option

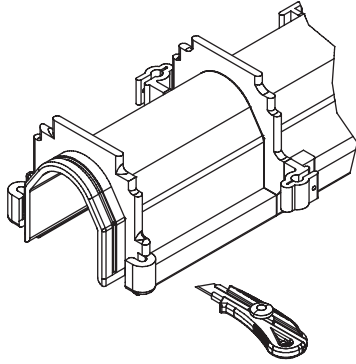

1 Score both sides of the rib with the utility knife.

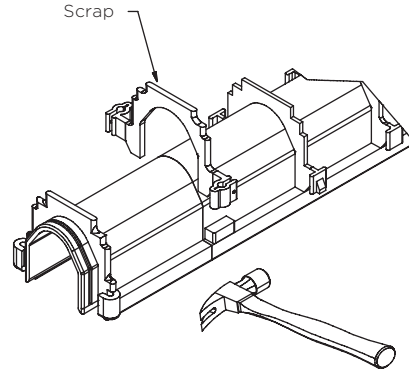

2 Tap rib with a hammer to remove rib when necessary.

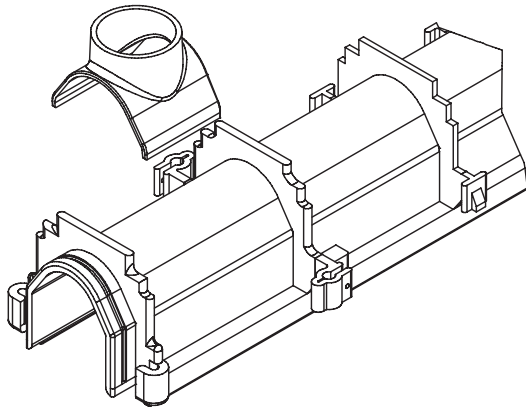

3 Attach bottom outlet to channel with hardware provided.

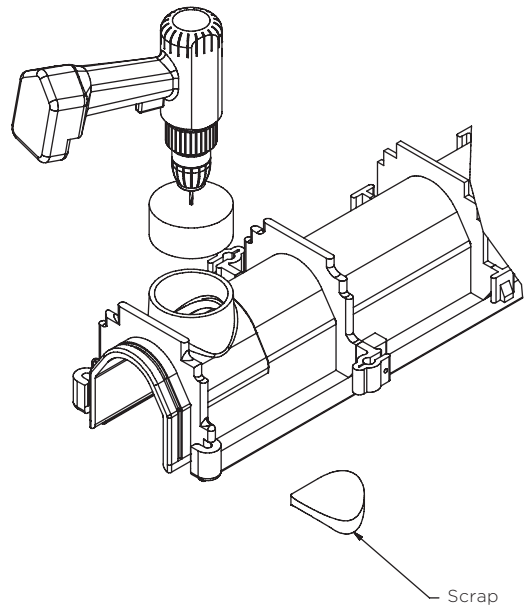

4 Cut out hole with hole saw that matches inside diameter of outlet.



## Z886 Channel Connection

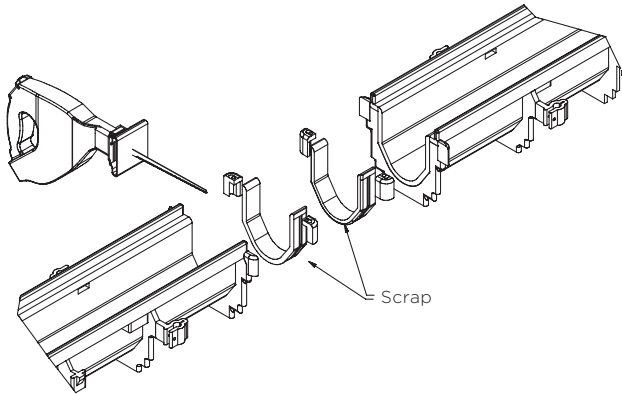

- 1 When job layout calls for male-to-male channel connection, cut male ends to be flush with end of integral frame on the ends that will be connected.

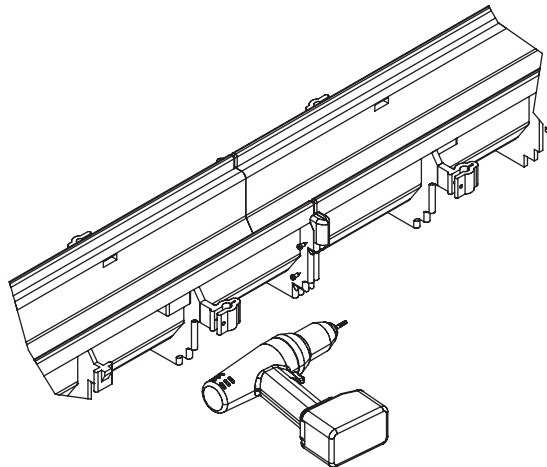

- 2 Screw the ribs together with the hardware provided. This method can also be used if you have a female-to-female connection.

## Z886 Neutral Cut Channel Connection

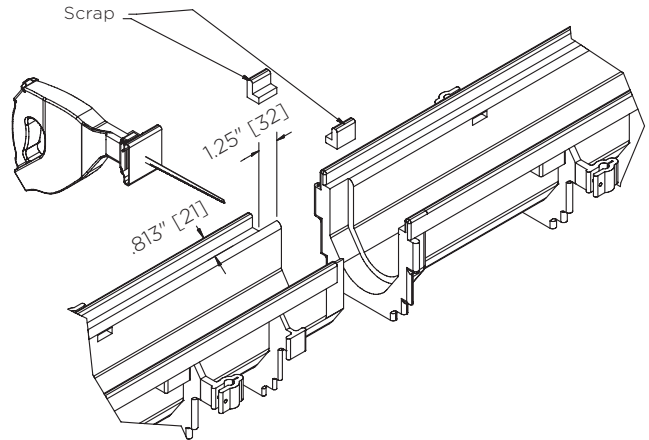

- 1 Cut a 1-1/4" [32] by 13/16" [21] section out of the end of the channel. This enables the end to act as a male end.

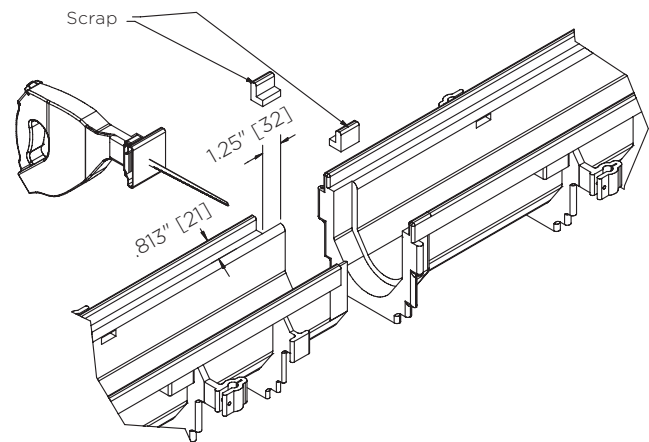

- 2 After removing the cutouts, attach channel through the female connection with hardware provided.



## Z886 Connecting the Trench

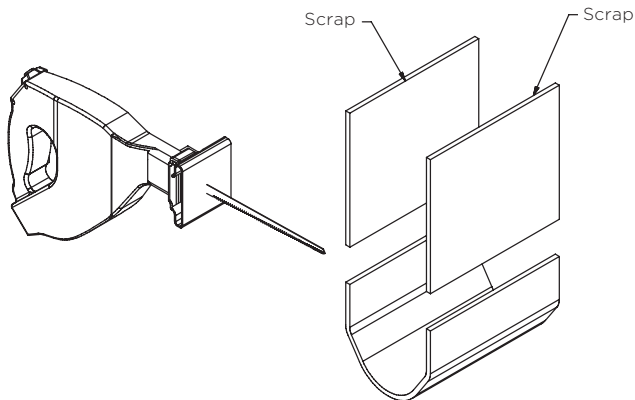

- 1 Cut joint connector to height. It should fit snug on the radius portion of the trench to just below the upper lip of the channel.

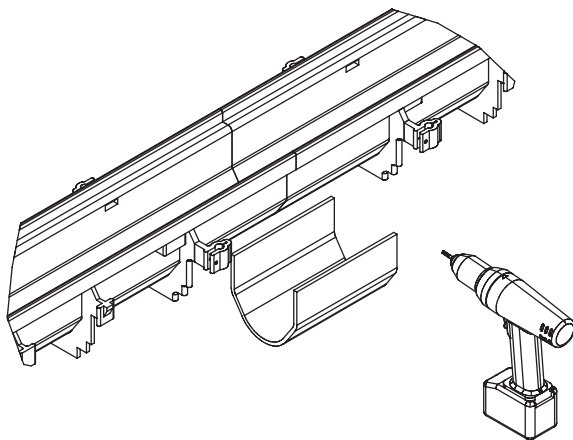

- 2 Attach to the channels with the hardware provided.

## Z886-HD Channel Connection

WITH JOINT CONNECTOR

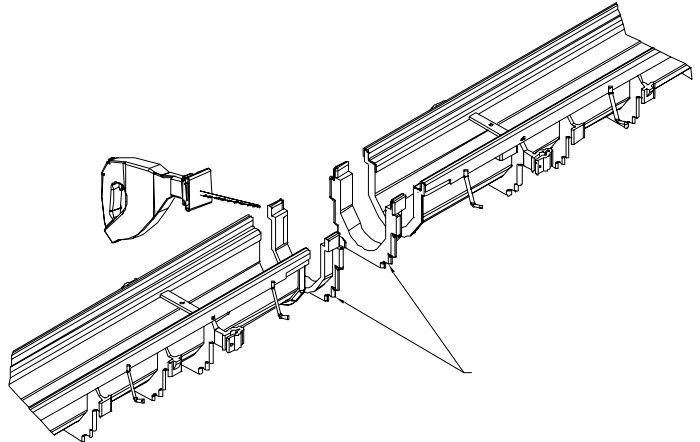

- 1 When job layout calls for female-to-female channel connection with HD frame, cut female ends to be flush with end of the HD frame on the ends that will be connected.

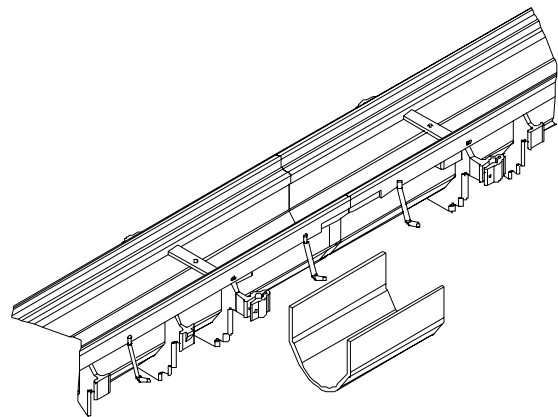

- 2 Screw the joint connector to the channel with the hardware provided. This method can also be used if you have a male-to-male connection. Ends are not cut off, but ribs will need to be trimmed (See page 7).



# Z886 Connecting the Trench with Sidewalls

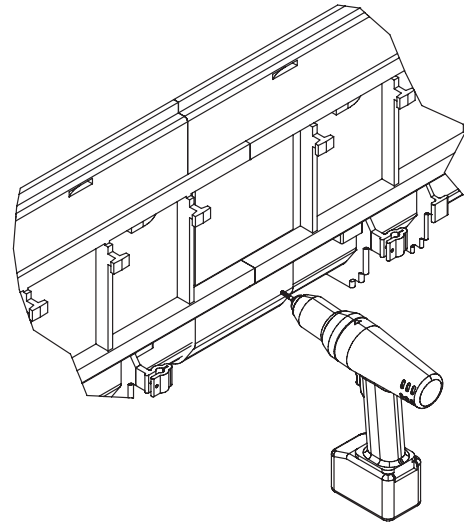
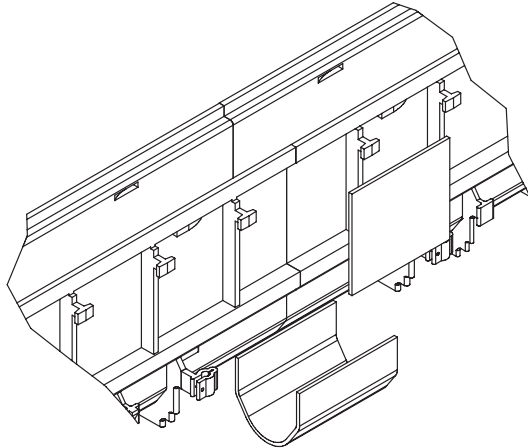

**1** When using sidewalls with a joint connector, be sure to keep the trimmed pieces to attach to the sidewall portion of the trench using the hardware provided.

**2** Attach to the channels with the hardware provided.

# Z886 Connecting the Trench

Channels should be installed from deep or outlet end to shallow end. This allows the next shallower channel's male connection to easily set onto the previous channel lip. Stake in place with No. 4 rebar (by others) and attach with the provided connection hardware.

## SEALING

- Channel connections are designed to be a good seal, meaning concrete aggregate will not intrude into the trench.
- Silicone sealant may be used as a gasket between the channels for a better seal.
- Channel connections may be welded with an HDPE welding gun for the best seal.

## CONNECTIONS

- The maximum gap between frames is 1/4" [6].

Rebar length dictated by trench depth and substrate for positive anchoring while setting to resist floating.

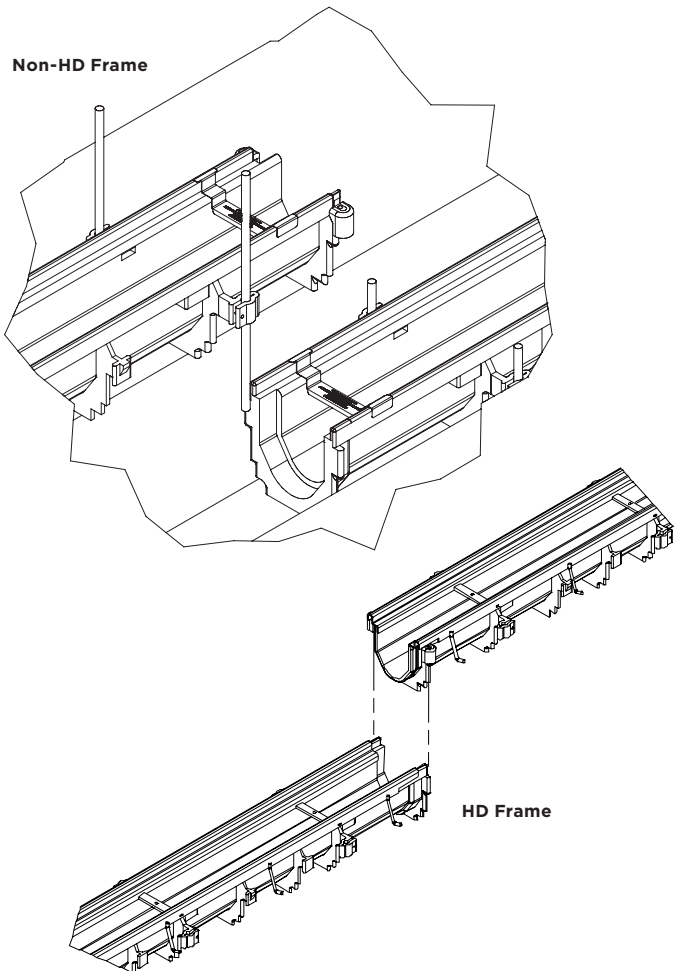

# Z886 Catch Basins

## CUT CHANNEL INSTALL

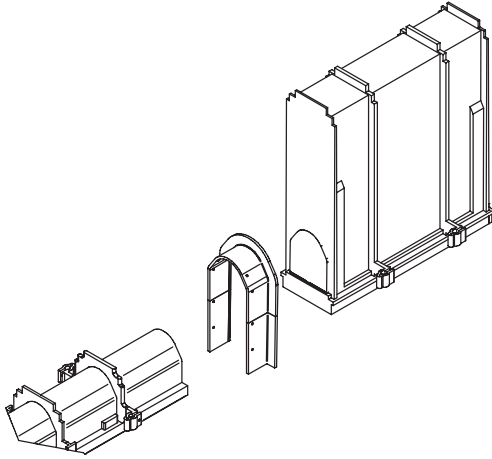

- 1 To make connection to a basin, invert the basin and channel and trace the outline of the channel onto the basin. This should be done for all sizes of basins.

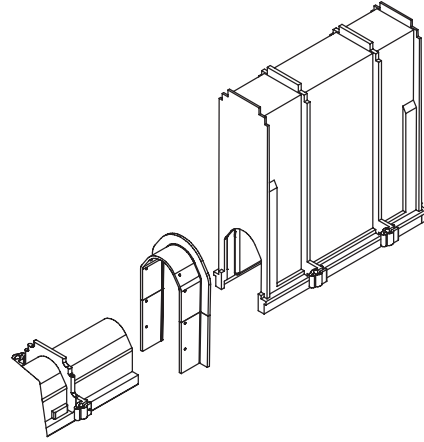

- 2 Cutting the hole in the basin can be easily accomplished with the use of a hand saw or power reciprocating saw. Cut out the material inside of the traced area, including the upper lip under the frame. **Do not cut the frame.**

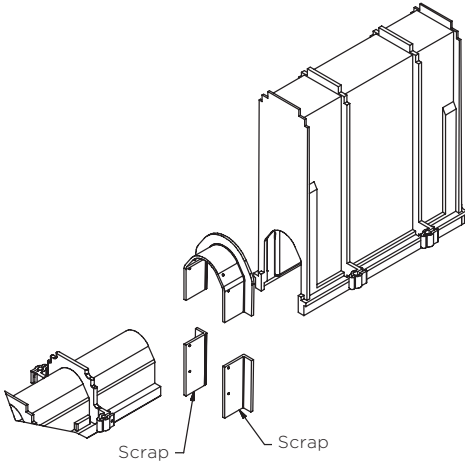

- 3 After the channel outline is removed from the catch basin, cut the inlet adapter to the height of the hole in the basin. Secure the inlet adapter to the basin using the hardware provided. Be sure to use silicone caulk or construction adhesive to seal the adapter to the basin.

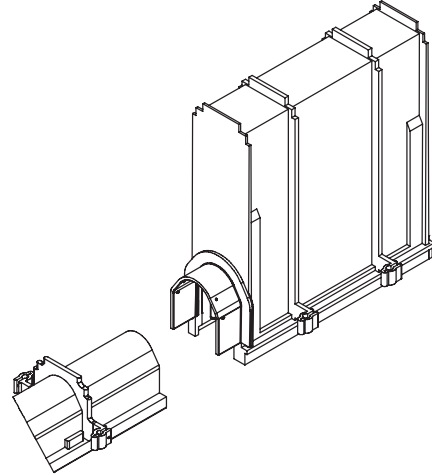

- 4 Slide the male end of the channel into the inlet adapter, attaching them together with the supplied hardware and silicone caulk or construction adhesive.



# Z886 Catch Basins

## FULL CHANNEL INSTALL

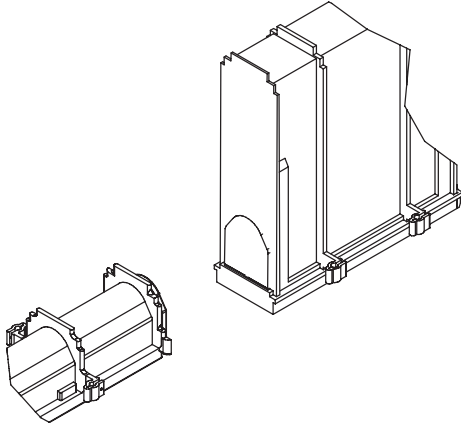

- 1** To make connection to a basin, invert the basin and channel and trace the outline of the channel onto the basin. This should be done for all sizes of basins. Then remove the mechanical joint.

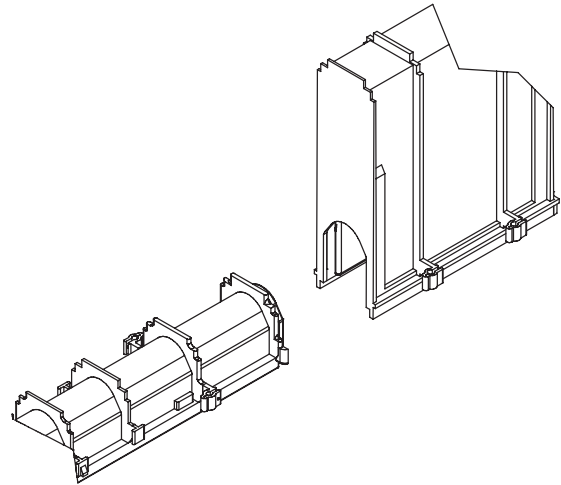

- 2** Cutting the hole in the basin can be easily accomplished with the use of a hand saw or power reciprocating saw. Cut out the material inside of the traced area.

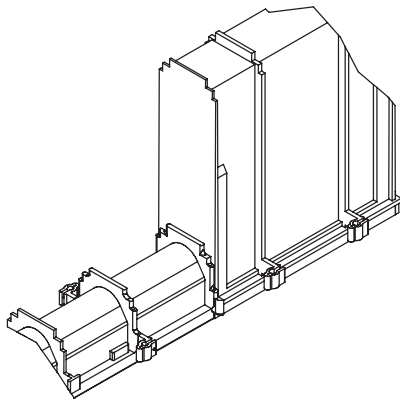

- 3** Slide the male end of the channel into the basin attaching them together with the supplied hardware and silicone caulk or construction adhesive through the ribbing.

# Z886 Catch Basins

## FULL CHANNEL INSTALL WITH HEAVY-DUTY FRAME

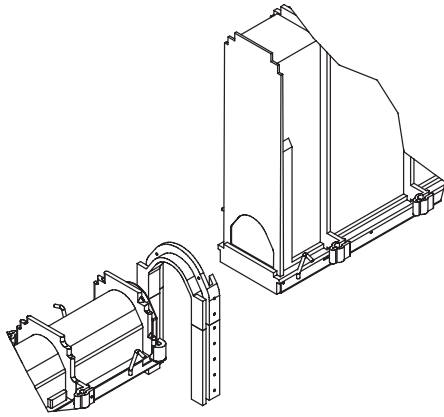

- 1 To make connection to a basin, invert the basin and channel and trace the outline of the channel onto the basin. This should be done for all sizes of basins.

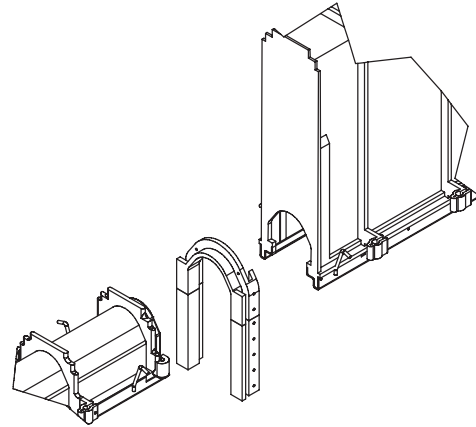

- 2 Cutting the hole in the basin can be easily accomplished with the use of a hand saw or power reciprocating saw. Cut out the material inside of the traced area.

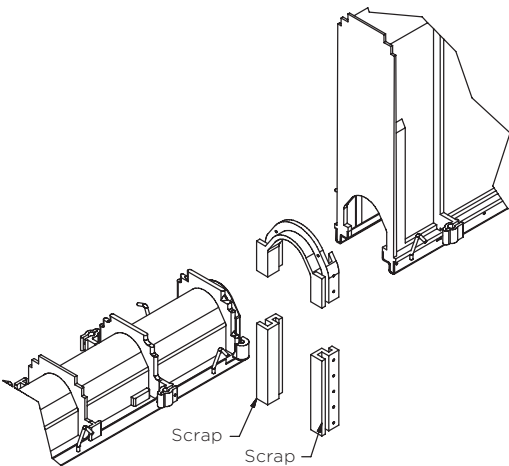

- 3 After the channel outline is removed from the catch basin, cut the inlet adapter to just under the top of the mechanical joint. Secure the inlet adapter to the basin using the hardware provided. Be sure to use silicone caulk or construction adhesive to seal the adapter to the basin.

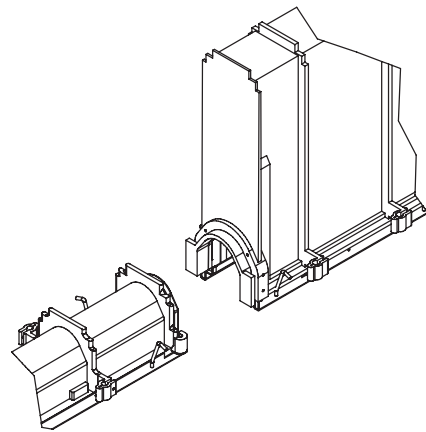

- 4 Slide the male end of the channel into the inlet adapter attaching them together with the supplied hardware and silicone caulk or construction adhesive.



# Z886

## Setting the Trench

### NEW CONSTRUCTION

Typically, a trench system is assembled from the outlet back. Starting with the deepest section or catch basin, set the first channel utilizing the integral rebar clip anchoring system. Rebar clips are on both sides of each trench drain for easy attachment to No. 4 rebar stakes. Slide the rebar into the rebar clips. Then drive the stakes into the ground for positive anchoring. Secure the trench to the rebar stakes with the hardware provided with bag No. 841.

Adjust the trench to the desired elevation and repeat the process with the next channel.

Set trench on rebar 1" [25] above final grade — this allows final elevation adjustment with a hammer prior to pouring concrete.

It is recommended to pour concrete the same day the trench is set.

Recess trench 1/8" [3] below finish grade to ensure positive flow into trench grate.

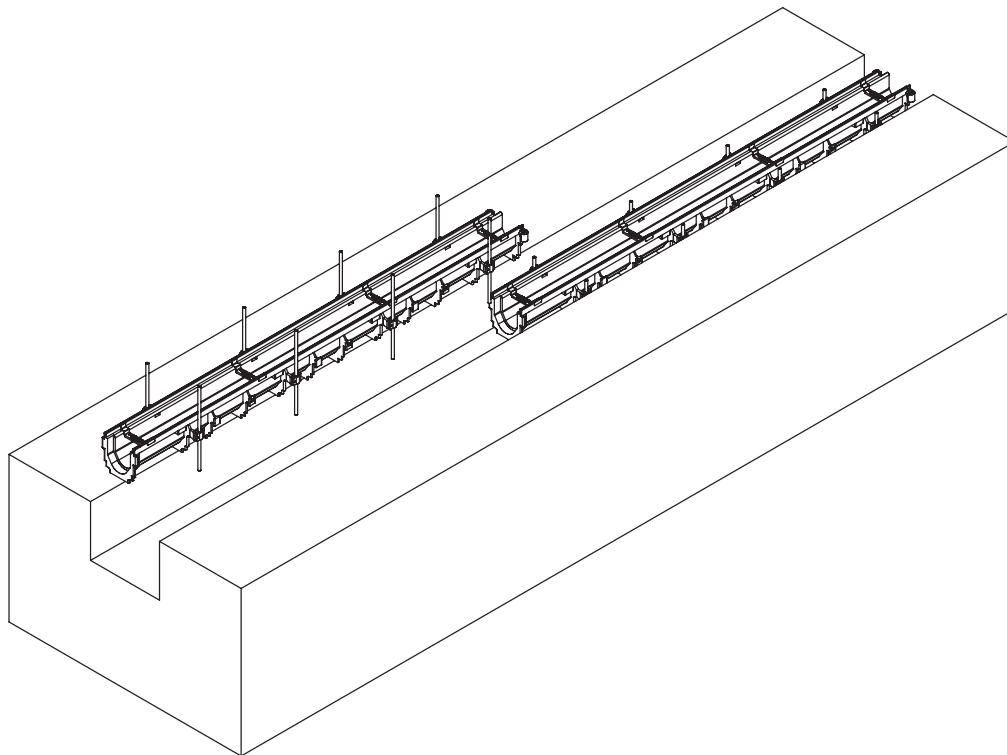

# Z886 Setting the Trench

BLOCKOUT, RETROFIT, HANGING

An alternative means of installation is to suspend the trench drain as shown. Wooden braces to hang the trench run can be attached to the drain body through the grate lockdown bars as illustrated below.

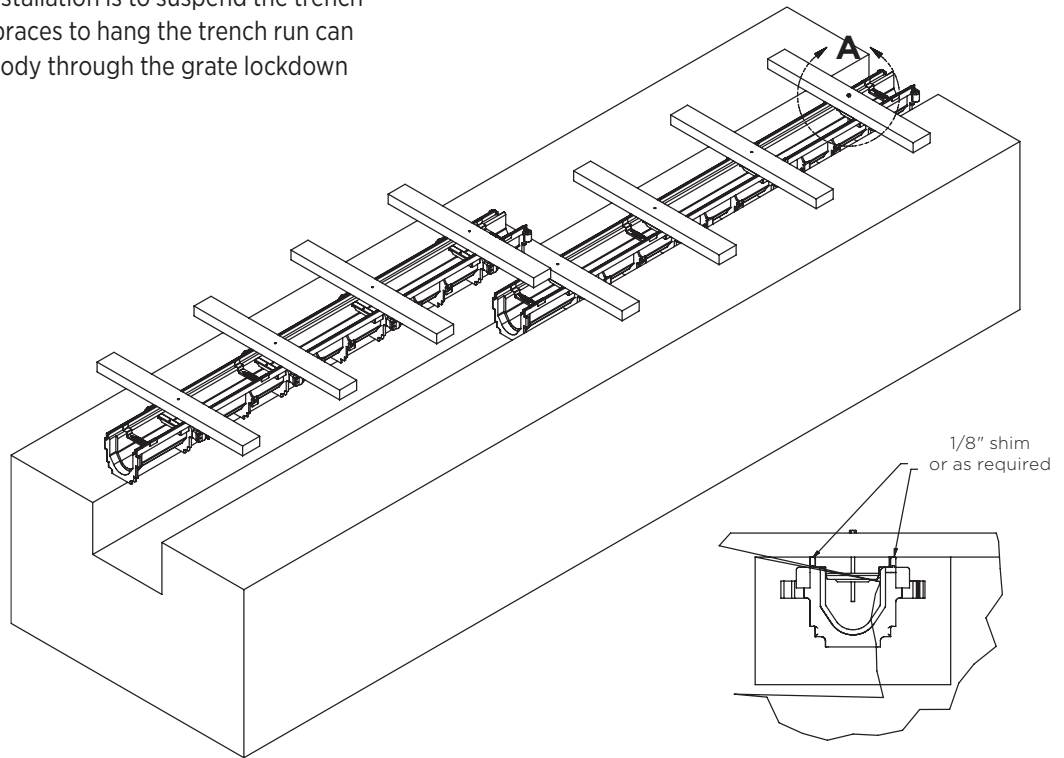



# Z886 Concrete Pour and Finish

Pour the concrete around the three sides of the trench drain. Be certain to adequately **vibrate** the concrete as it is being placed. Proper vibration will eliminate any unwanted voids within the concrete pour. If sidewalls are used, a first and second pour are recommended. **Verify layout is correct prior to pouring concrete.**

## PLACING CONCRETE

- Adhere to check that the trench drain is in the location required per the layout drawings prior to pouring concrete.
- Standard concrete practices with expansion and crack induction joints shall be followed based upon local codes and standards.
- The trench drain shall not be used as an expansion joint.

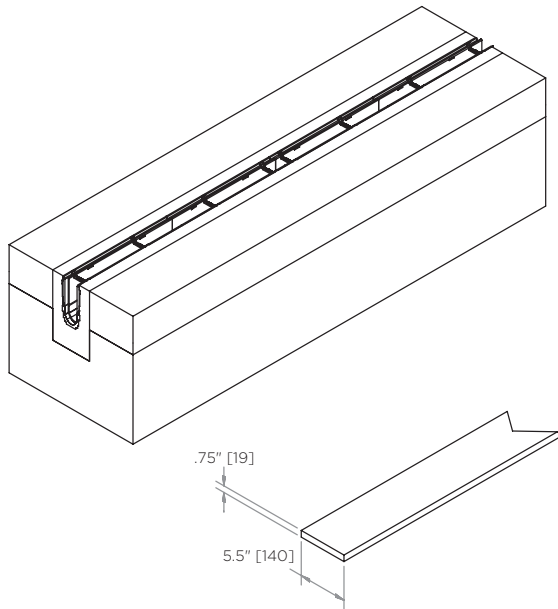

The use of nominal 1x6 (3/4" x 5-1/2") [20 x 140] lumber supplied by others may be used to keep channel clear during the concrete pour.

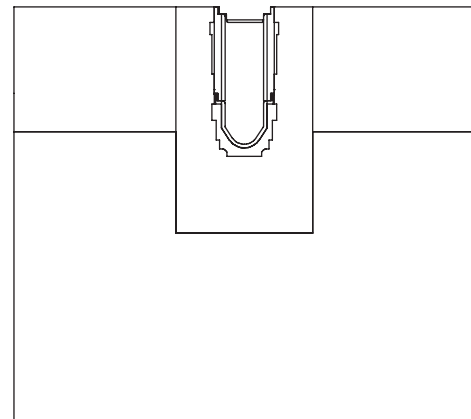
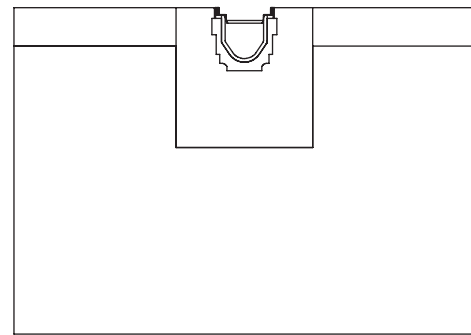
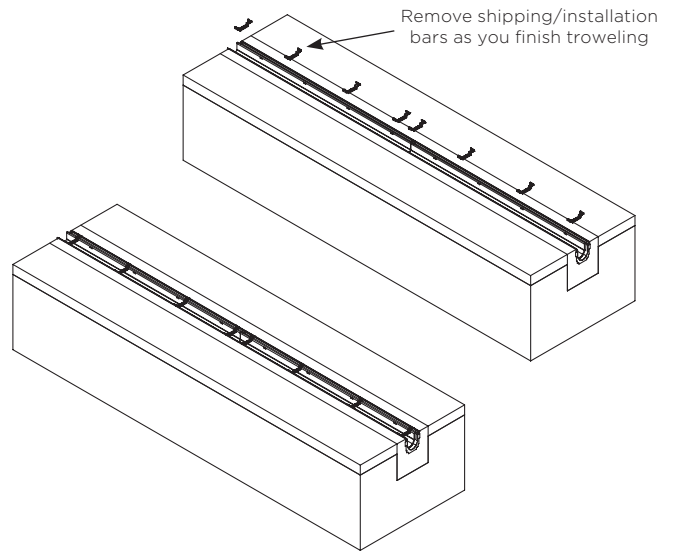

Finish troweling should be done to set the top edge of the trench drain 1/8" [3] below the floor grade. Remember to compensate for the concrete shrink that may occur during cure so that the edge of the trench drain does not protrude above the finished floor grade.



# Z886 Internal Sidewall Extension Bracing

## INSTALLATION WITH SIDEWALL EXTENSIONS

Use reinforcing every 10" [254] per bracing schedule  
(bracing provided by others).

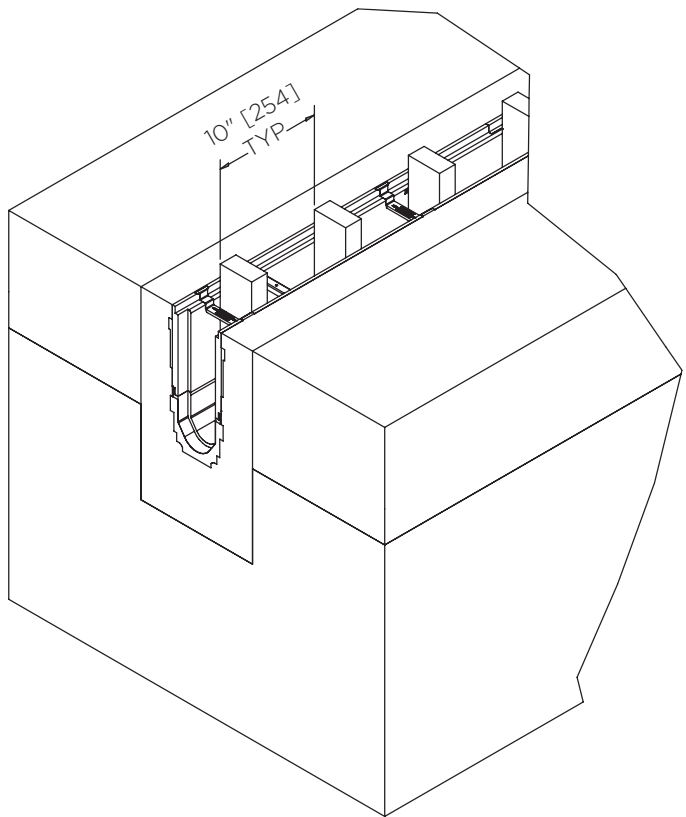
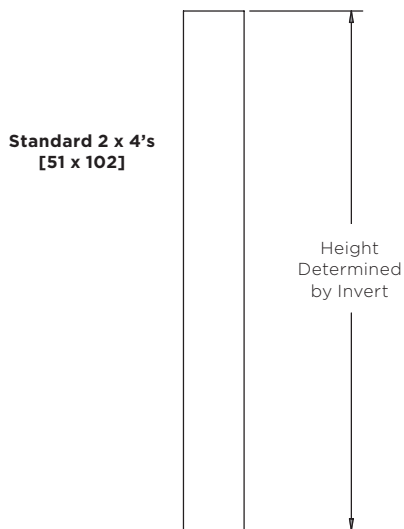



# Z886 Sidewall Concrete Pour

FULL CHANNEL INSTALL WITH HEAVY-DUTY FRAME

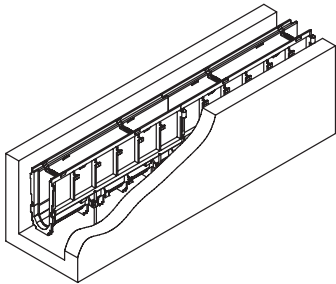

**1** Set the channel to the correct height.

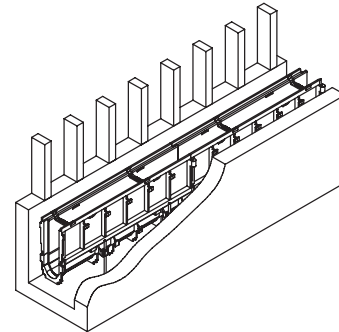

**2** Install reinforcing per bracing schedule (bracing provided by others).

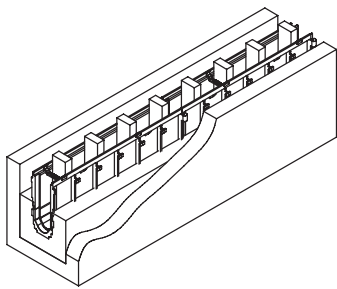

**3** Using the standard concrete pouring method, pour concrete so it is about 8" [204] from the top of the trench.

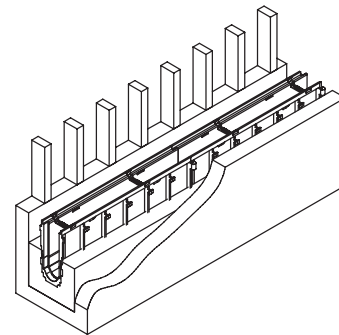

**4** Remove internal sidewall bracing.

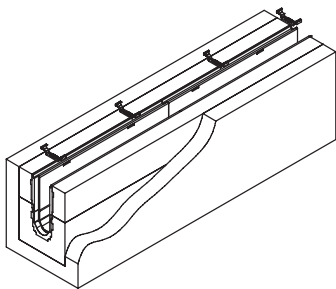

**5** Pour the remaining concrete, remove shipping/ installation bars, and use standard finishing practices to finish the concrete.

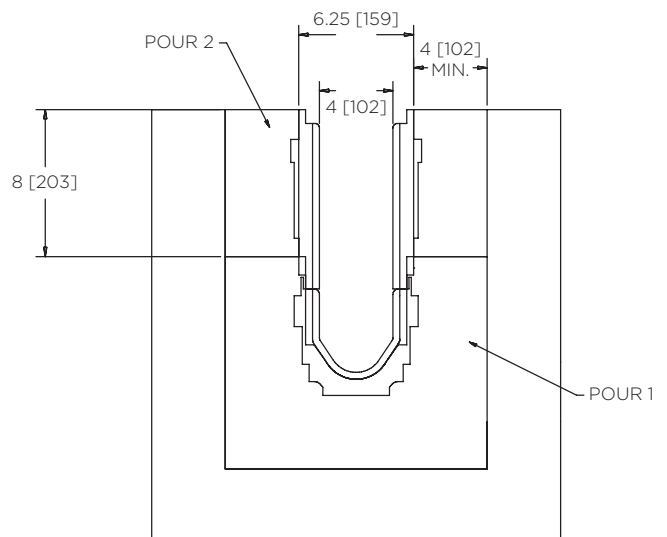

# Z886

## Installing Grates

After the concrete has been poured, vibrated, and given sufficient time to dry, grate lockdown bolts must be installed. The center of the grate should straddle the tie strap that spans the frame. The exception is when both channels and frames are cut. To place these grates, line up the lockdown hole in the grate with the lockdown hole in the tie strap. Lockdown bolts can be installed using a 1/2" [13] socket.

### LOCKING DOWN GRATES

- Start all lockdown bolts on each grate into the lockdown prior to tightening them down.
- There may be gaps up to 1/4" [6] to ensure all grates will lockdown.

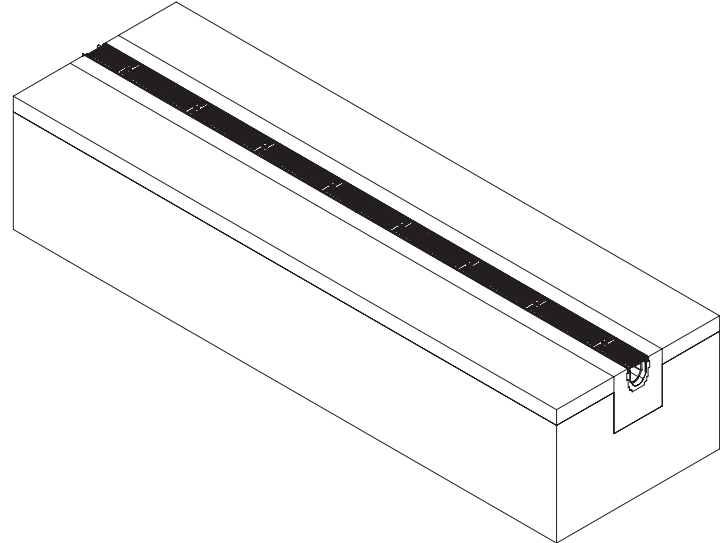

# Ti) SALES

36 Hudson Rd  
Sudbury MA 01776



800-225-4616  
[www.tisales.com](http://www.tisales.com)

⚠ **WARNING:** Cancer and Reproductive Harm - [www.P65Warnings.ca.gov](http://www.P65Warnings.ca.gov)  
⚠ **ADVERTENCIA:** Cáncer y daño reproductivo - [www.P65Warnings.ca.gov](http://www.P65Warnings.ca.gov)  
⚠ **AVERTISSEMENT:** Cancer et effets néfastes sur la reproduction -  
[www.P65Warnings.ca.gov](http://www.P65Warnings.ca.gov)

**ZURN INDUSTRIES, LLC** Trench Drainage Operation  
1801 Pittsburgh Avenue, Erie, PA 16502, 855.663.9876

In Canada: **ZURN INDUSTRIES LIMITED** 7900 Goreway Drive, Unit 10, Brampton, Ontario L6T 5W6, 877.892.5216

Form No. ZMKTG220-11, 5/18



US 1.855.ONE.ZURN CANADA 1.877.892.5216 [ZURN.COM](http://ZURN.COM)